

**Bray to City Centre
Core Bus Corridor Scheme**
June 2023

**Preliminary
Design
Report**

Appendix F
Structures Reports

CONTENTS

F1	Retaining Walls Preliminary Design Report
F2	St Laurence Subway Preliminary Design Report
F3	Loughlinstown Roundabout Preliminary Design Report
F4	St Annes Retaining Wall Preliminary Design Report
F5	UCD Flyover Record of Structural Review
F6	St Columcille Footbridge Record of Structural Review
F7	St Annes Retaining Wall Record of Structural Review



Appendix F1
Retaining Walls Preliminary
Design Report

© Copyright 2023 Jacobs Engineering Ireland Limited. The concepts and information contained in this document are the property of Jacobs. Use or copying of this document in whole or in part without the written permission of Jacobs constitutes an infringement of copyright.

Limitation: This document has been prepared on behalf of, and for the exclusive use of Jacobs' client, and is subject to, and issued in accordance with, the provisions of the contract between Jacobs and the client. Jacobs accepts no liability or responsibility whatsoever for, or in respect of, any use of, or reliance upon, this document by any third party.

**Preliminary Design Report-
Consultation**

STA-1b

Categories 1, 2 & 3

Scheme Name

Name and Location – BusConnects Route 13 Bray to City Centre, Dublin

Structure(s)

Name and nature of the Structure(s) – Route 13 Retaining Structures

Preliminary Design Report

Reference - R13-RW023, R13-RW024, R13-RW036, R13- RW038, R13-RW013, R13-RW016, R13-
RW017

Revision - M01

Date - 27th January 2023

Submitted by

Signed  _____

Name John McElhinney

Position Structural Discipline Lead (Team Leader)

Organisation Jacobs Engineering

Date 27/01/2023

Structures Section confirmation of consultation

Signed _____

Name _____

Position _____

Date _____

* This application should appear as the first page after the cover of the Preliminary Design Report.

Contents

1. Introduction.....1

1.1 Brief1

1.2 Background.....1

1.3 Previous Studies2

2. Site & Function.....3

2.1 Site Location3

2.2 Function of Site and Obstacles Crossed.....3

2.3 Choice of location.....4

2.3.1 R13-RW0234

2.3.2 R13-RW0244

2.3.3 R13-RW036.....4

2.3.4 R13-RW038.....4

2.3.5 R13-RW013.....4

2.3.6 R13-RW016.....4

2.3.7 R13-RW017.....4

2.4 Site Description and Topography.....4

2.4.1 R13-RW023.....4

2.4.2 R13-RW024.....5

2.4.3 R13-RW036.....5

2.4.4 R13-RW038.....6

2.4.5 R13-RW013.....6

2.4.6 R13-RW016.....7

2.4.7 R13-RW017.....7

2.5 Vertical and Horizontal Alignments8

2.6 Cross Sectional Dimensions.....8

2.7 Existing Underground and Overground Services8

2.8 Geotechnical Summary11

2.9 Hydrology and Hydraulic Summary11

2.10 Archaeological Summary.....11

2.11 Environmental Summary11

3. Structure & Aesthetics.....12

3.1 General Description of Recommended Structure and Design Working Life12

3.1.1 R13-RW02312

3.1.2 R13-RW02413

3.1.3 R13-RW036.....13

3.1.4 R13-RW038.....14

3.1.5 R13-RW013.....15

3.1.6 R13-RW016.....16

3.1.7 R13-RW017.....17

3.2	Aesthetic Considerations.....	19
3.2.1	R13-RW023.....	19
3.2.2	R13-RW024 & R13-RW036.....	20
3.2.3	R13-RW038 & R13-RW013.....	20
3.2.4	R13-RW016.....	20
3.2.5	R13-RW017.....	20
3.3	Proposals for the Recommended Structure	21
3.3.1	Proposed Category	21
3.3.2	Span Arrangement.....	21
3.3.3	Minimum Headroom Provided.....	21
3.3.4	Approaches including run-on arrangements.....	21
3.3.5	Foundation Type.....	21
3.3.6	Substructure	21
3.3.7	Superstructure	21
3.3.8	Articulation Arrangement.....	21
3.3.9	Vehicle Restraint System	21
3.3.10	Drainage	22
3.3.11	Durability.....	22
3.3.12	Sustainability.....	22
3.3.13	Inspection and Maintenance.....	22
4.	Safety.....	23
4.1	Traffic Management during construction.....	23
4.2	Safety during construction.....	23
4.3	Safety in use.....	23
4.4	Lighting.....	23
5.	Design Assessment Criteria.....	24
5.1	Actions.....	24
5.1.1	Permanent Actions.....	24
5.1.2	Snow, Wind and Thermal Actions.....	24
5.1.3	Actions Relating to Normal Traffic	24
5.1.4	Actions Relating to Abnormal Traffic.....	24
5.1.5	Footway or Footbridge Live Loading.....	24
5.1.6	Provision for Exceptional Abnormal Loads.....	24
5.1.7	Accidental Actions.....	24
5.1.8	Actions during Constructions.....	24
5.1.9	Any Special Loading not Covered Above.....	24
5.2	Authorities consulted and any special conditions required.....	24
5.3	Proposed Departures from Standards	25
5.4	Proposed methods of dealing with aspects not covered in standards.....	25
6.	Ground Conditions.....	26

6.1	Geotechnical Classification	26
6.2	Ground Conditions	26
6.2.1	R13-RW023	26
6.2.2	R13-RW024	27
6.2.3	R13-RW036	27
6.2.4	R13-RW038	27
6.2.5	R13-RW013	27
6.2.6	R13-RW016	27
6.2.7	R13-RW017	27
7.	Drawings and Documents	29
7.1	List of All Documents Accompanying the Submission	29

1. Introduction

1.1 Brief

Jacobs have been appointed by the National Transport Authority (NTA) to undertake the Engineering Design Services for the Planning Stage through to the end of the Statutory Process of the BusConnects Radial Core Bus Corridors Infrastructure Upgrade Programme (the Programme). The Project has been split in four packages with Jacobs undertaking Package B.

This report outlines the Preliminary Design for the retaining structures on Core Bus Corridor (CBC) 13 Bray to City Centre. The other routes undertaken by Jacobs shall be covered in separate reports. The scope of this report extends to structures considered within the Dún Laoghaire-Rathdown County Council (DLRCC) & Wicklow Country Council maintenance boundary. Walls within other maintaining authorities' boundaries along the proposed scheme will be covered in separate reports.

1.2 Background

The National Transport Authority (NTA) published the Transport Strategy for the Greater Dublin Area, 2016 – 2035 at the beginning of 2016. The strategy identifies a “Core Bus Network”, representing the most important bus routes within the Greater Dublin area, generally characterised by high passenger volumes, frequent services, and significant trip attractors along the routes. The identified core network comprises sixteen radial bus corridors, three orbital bus corridors and six regional bus corridors.

The Strategy states that it is intended to provide continuous bus priority, as far as is practicable, along the core bus routes. This will result in a more efficient and reliable bus service with lower journey times, increasing the attractiveness of public transport in these areas and facilitating a shift to more sustainable modes of transport. The Bray to City Centre Core Bus Corridor is identified as part of the Core Bus Network.

In March 2018, BusConnects Dublin was launched as part of major investment programme, including Metrolink and the Dublin Area Rapid Transport (DART) Expansion Programme, to improve public transport in Dublin, as part of the National Development Plan 2018-2027. The Bray to City Centre CBC serves the area to the south of Dublin city, creating an improved public transportation link for areas along the corridor.



Figure 1.2: BusConnects Dublin Radial CBC Network

1.3 Previous Studies

The first non-statutory public consultation on the BusConnects CBCs took place on a phased basis between November 2018 and May 2019. The second round of public consultations occurred between March 2020 and April 2020. A third round of public consultations then followed between November 2020 and December 2020.

Consultation with the principal project stakeholders (i.e. Dublic City Council, Transport Infrastructure Ireland, Utility companies and the National Transport Authority) has also taken place.

A desktop study was undertaken to identify the existing structures within the project extents, with site inspections undertaken where information was limited.

2. Site & Function

2.1 Site Location

Along Bray to City Centre Core Bus Corridor there are 8 locations within the management area of Dún Laoghaire Rathdown County Council, identified in the previous stage, that require retaining structures to accommodate the proposed widened cross section. 5 of these structures have a retained height greater than 1.5 m and fall within the scope of this report. Two further walls were identified as possessing sufficient importance to be included in the scope of this report.

Along Bray to City Centre Core Bus Corridor there are 2 locations within the management of Wicklow County Council identified in the previous stage which require retaining structures to accommodate the proposed widened cross section. All these structures have a retained height greater than 1.5 m and fall within the scope of this report.

See Table 2.1 below for walls considered within the scope of this scheme. Following on from the updated highway design R13-RW025 has been removed from the scope of this scheme due to alignment changes that avoid this structure. The requirement for retaining wall R13-RW033 at the Belton Terrace location has been designed out following the latest highway alignment.

Wall Reference	Retained Height (m)	Chainage Start	Chainage End	Definition
R13-RW023	2.5	E 0+10	A 14+770	North side of Stonebridge Road between R837 Dublin Road junction and entrance to Rathmichael National School (MAP 42, Appendix A)
R13-RW024	1.5*	A 14+750	A 14+795	East side of R837 Dublin Road between Rathmichael Park & Stonebridge Road junctions (MAP 42, Appendix A)
R13-RW036	1.5*	A 14+800	A 14+980	East side of R837 Dublin Road south of Stonebridge Road junction (MAP 42 & 43, Appendix A)
R13-RW038	1.8	A 17+040	A 17+080	East side of R119 Dublin Road north of entrance to Woodbrook Golf Club (MAP 48, Appendix A)
R13-RW013	1.5	A 17+190	A 17+290	East side of R119 Dublin Road between Woodbrook College & M11 Junction 5 roundabout. (MAP 49, Appendix A)
R13-RW016	2.5	A 18+085	A 18+130	East side of R761 Dublin Road to the north of the Upper Dargle Road junction (MAP 51, Appendix A)
R13-RW017	2.5*	A 18+150	A 18+190	East side of R761 Dublin Road to the south of the Upper Dargle Road junction (MAP 51, Appendix A)

* Height subject to confirmation by topographical survey.

Table 2.1: Summary of walls within the scope of this report

2.2 Function of Site and Obstacles Crossed

The retaining walls are needed to maintain the required ground level in the areas affected by the proposed new elements of the bus corridor, where the height difference is too high to be maintained with an embankment.

2.3 Choice of location

Walls are located where geometric constraints do not allow for traditional earthworks batters to be contained within the site boundaries.

2.3.1 R13-RW023

R13-RW023 is located on the north side of Stonebridge Road between the R837 Dublin Road junction and entrance to Rathmichael National School, forming the boundary between the highway and school grounds.

2.3.2 R13-RW024

R13-RW024 is situated on the east side of the R837 Dublin Road between Rathmichael Park & Stonebridge Road junctions.

2.3.3 R13-RW036

R13-RW036 is located on the east side of the R837 Dublin Road south of the Stonebridge Road junction.

2.3.4 R13-RW038

R13-RW038 is located on the east side of R119 Dublin Road north of the entrance to Woodbrook Golf Club.

2.3.5 R13-RW013

R13-RW013 is situated on the east side of the R119 Dublin Road between Woodbrook College & M11 Junction 5 roundabout.

2.3.6 R13-RW016

R13-RW016 is situated on the east side of the R761 Dublin Road to the north of the Upper Dargle Road junction. The site consists of an existing rendered boundary wall to the historic Ravenswell House (grounds now belonging to Ravenswell Primary School) that has been identified by heritage and landscape specialists as an important original feature.

2.3.7 R13-RW017

R13-RW017 is located on the east side of the R761 Dublin Road to the south of the Upper Dargle Road junction, immediately south of R13-RW016.

2.4 Site Description and Topography

The surrounds comprise of a brownfield site, with walls located adjacent to existing carriageways and road embankments.

2.4.1 R13-RW023

The existing wall comprises of a concrete gravity wall topped with steel fencing of approx. 40m length at the eastern end. A wooden fence runs along the remainder of the wall up to the school entrance. Vegetation is present along the wall's entire length. The condition of the existing wall is poor with large vertical cracks evident along the entire length. The proposed wall is required to retain the land owned by the school at a height of 2m for approx.. 35m length, to accommodate a new widened footpath and cycle lane.



Figure 2.4.1: Photo of wall location R13-RW023

2.4.2 R13-RW024

An existing wall runs consisting of masonry construction and painted infill fencing with masonry columns at regular intervals along the length. The proposed wall is required to support the new bus lane and widened footpath. The wall must be capable of supporting a traffic surcharge and retain a height varying between 1m-2m for approx. 40m length.



Figure 2.4.2: Photo of wall location R13-RW024

2.4.3 R13-RW036

The site contains multiple gravity stone masonry walls and hedges which form the boundaries to private properties. The proposed wall is required to retain privately owned land to accommodate the highway widening, including a cycle lane and widened footpath.



Figure 2.4.3: Photo of wall location R13-RW036

2.4.4 R13-RW038

Currently a 2m high 19th century stone rubble boundary wall belonging to Woodbrook House which has been identified as having historic importance. A slatted wooden fence is situated at the entrance to the golf club. The proposed highway alignment encroaches onto an area of heavily vegetated land belonging to Corke Lodge. The proposed wall must be capable of resisting pedestrian surcharge and accidental wheel loads and is expected to measure 1.8m in height and 40m in length.



Figure 2.4.4: Photo of wall location R13-RW038

2.4.5 R13-RW013

The existing wall is a stone rubble boundary wall belonging to Front Lodge which has been identified to have historical importance. The northern end consists of the original wall construction with granite rendered finish, while the southern end has been reconstructed without render. Both walls mark the boundary between the

highway and private grounds. The proposed wall must be capable of resisting pedestrian surcharge and accidental wheel loads. This is expected to have a retained height of 1.5m and a length of 100m.



Figure 2.4.5: Photo of wall location R13-RW013

2.4.6 R13-RW016

From available information the wall appears to have been relocated to its current position in the late 19th century with its curved entrance walls constructed at a similar time. The pebble dash render and concrete copings found on the section adjacent to the highway appear to be from works undertaken in the early 20th century. Beneath the render the wall comprises rubble stone masonry construction. The proposed wall is required to retain grounds owned by the school to accommodate a new bus lane, cycle lane and footpath. The wall is expected to retain a height of 2.5m along an approx. 45m length.



Figure 2.4.9: Photo of wall location R13-RW016

2.4.7 R13-RW017

The site consists of a rendered boundary wall of historical value marking the boundary between the highway and the former Ravenswell Primary School grounds. The proposed wall is required to retain the new highway alignment of a bus lane, cycle lane and footway, and will support a traffic surcharge loading. The retained height of the wall varies between 1m-2m along a length of approx. 40m. The north of the wall will need to tie into the existing historical wall which will be retained in order to retain the protected tree located immediately behind the

wall. At the south end the wall will tie into an existing wall, it is expected that this wall will be reconstructed as part of a development of this plot of land.



Figure 2.4.10: Photo of wall location R13-RW017

2.5 Vertical and Horizontal Alignments

Refer to the road design drawings for the proposed vertical and horizontal road alignments along the scheme.

2.6 Cross Sectional Dimensions

Not applicable for retaining structures.

2.7 Existing Underground and Overground Services

Clashes with existing utilities are potential hazards which would have major impacts on the construction and buildability of the route. Any clashes would need mitigating measures to prevent disruption to the services they provide. The affected services would require diversion prior to and during construction works. Depending on the size of the asset these mitigation works could range broadly in cost and complexity, significantly impacting the construction programmes at each location.

At locations where utilities run parallel to a proposed wall the level of the foundation should be constructed such that no loading is transferred into the assets. This could require additional reductions in foundation level, greater than that needed solely for structural purposes. Cover to existing utilities should be confirmed in detail design and the levels of foundations adjusted accordingly. Consequently, a conservative approach has been adopted when estimating land takes at location identified for protection against clashing with utilities assets. Where there is a direct clash with a buried assets and diversion is not practical, the proposed solution should accommodate these assets.

A schedule of identified clashes can be seen in Table 2.7

Wall Reference	Underground Services	Overground Services
R13-RW023	<u>Electricity</u>	4 No. Overhead low voltage ESB - to be diverted behind

	<p>Proximity to underground high voltage ESB at eastern end - to be retained (see drawing BCIDB-JAC-UTL_UE-0013_XX_00-DR-CU-0042)</p> <p><u>Water</u></p> <p>2 No. >225mm DIA water mains - to be retained (see drawing BCIDB-JAC-UTL_UW-0013_XX_00-DR-CU-0042)</p> <p><u>Gas</u></p> <p>Proximity to GNI low pressure gas asset at eastern end - to be retained (see drawing BCIDB-JAC-UTL_UG-0013_XX_00-DR-CU-0042)</p> <p><u>Data</u></p> <p>EIR cabling at eastern end - to be retained (see drawing BCIDB-JAC-UTL_UX-0013_XX_00-DR-CU-0042)</p>	<p>wall (see drawing BCIDB-JAC-UTL_UE-0013_XX_00-DR-CU-0042)</p>
<p>R13-RW024</p>	<p><u>Electricity</u></p> <p>Proximity to underground medium voltage ESB running parallel - to be diverted, new kiosk box behind wall (see drawing BCIDB-JAC-UTL_UE-0013_XX_00-DR-CU-0042)</p> <p>Proximity to underground low voltage ESB - to be retained (see drawing BCIDB-JAC-UTL_UE-0013_XX_00-DR-CU-0042)</p> <p><u>Water</u></p> <p>None Identified</p> <p><u>Gas</u></p> <p>None Identified</p> <p><u>Data</u></p> <p>Proximity to 2 No. EIR cabling parallel to carriageway - 1 No. cable to be diverted to run parallel approx. 1m from wall, 1 No. to be retained (see drawing BCIDB-JAC-UTL_UX-0013_XX_00-DR-CU-0042)</p> <p>Proximity to Virgin Media cabling parallel to carriageway - to be diverted (see drawing BCIDB-JAC-UTL_UX-0013_XX_00-DR-CU-0042)</p>	<p>Overhead low voltage ESB - to be diverted to run alongside wall (see drawing BCIDB-JAC-UTL_UE-0013_XX_00-DR-CU-0042)</p>
<p>R13-RW036</p>	<p><u>Electricity</u></p> <p>2 No. underground high voltage ESB - 1 No. to be diverted away from wall, 1 No. to be retained (see drawing BCIDB-JAC-UTL_UE-0013_XX_00-DR-CU-0042 & 0043)</p> <p>Underground low voltage ESB perpendicular to wall - to be retained (see drawing BCIDB-JAC-UTL_UE-0013_XX_00-DR-CU-0042 & 0043)</p> <p><u>Water</u></p> <p>Proximity to >225mm DIA water mains - to be retained (see drawing BCIDB-JAC-UTL_UW-0013_XX_00-DR-CU-0042 & 0043)</p> <p><u>Gas</u></p> <p>GNI low pressure gas asset - to be retained (see drawing BCIDB-JAC-UTL_UG-0013_XX_00-DR-CU-0042 & 0043)</p>	<p>Overhead low voltage ESB - to be diverted to run alongside wall (see drawing BCIDB-JAC-UTL_UE-0013_XX_00-DR-CU-0042 & 0043)</p>

	<p><u>Data</u> EIR cabling parallel to carriageway - to be diverted to run parallel approx. 2m from wall (see drawing BCIDB-JAC-UTL_UX-0013_XX_00-DR-CU-0042 & 0043) Virgin Media cabling parallel to carriageway - to be retained (see drawing BCIDB-JAC-UTL_UX-0013_XX_00-DR-CU-0042 & 0043)</p>	
R13-RW038	<p><u>Electricity</u> None Identified</p> <p><u>Water</u> None Identified</p> <p><u>Gas</u> None Identified</p> <p><u>Data</u> Proximity to 2 No. EIR cabling parallel to carriageway - to be diverted (see drawing BCIDB-JAC-UTL_UX-0013_XX_00-DR-CU-0048)</p>	<p>Overhead low voltage ESB - to be diverted to run alongside wall (see drawing BCIDB-JAC-UTL_UX-0013_XX_00-DR-CU-0048)</p>
R13-RW013	<p><u>Electricity</u> None Identified</p> <p><u>Water</u> >225mm DIA water mains - to be diverted away from wall (see drawing BCIDB-JAC-UTL_UW-0013_XX_00-DR-CU-0049)</p> <p><u>Gas</u> Proximity to GNI low pressure gas asset - to be diverted to run parallel approx. 3m from wall (see drawing BCIDB-JAC-UTL_UG-0013_XX_00-DR-CU-0049)</p> <p><u>Data</u> 3 No. EIR cabling in proximity to wall - 1 No. to be diverted to run parallel approx. 1m from wall, 2 No. to be retained (see drawing BCIDB-JAC-UTL_UX-0013_XX_00-DR-CU-0049) Virgin Media cabling in proximity to wall - to be retained (see drawing BCIDB-JAC-UTL_UX-0013_XX_00-DR-CU-0049)</p>	<p>Overhead low voltage ESB - to be diverted to run alongside wall (see drawing BCIDB-JAC-UTL_UX-0013_XX_00-DR-CU-0049)</p>
R13-RW016	<p><u>Electricity</u> Underground medium voltage ESB at the northern end of the wall crossing the alignment at an angle - to be protected (see drawing BCIDB-JAC-UTL_UX-0013_XX_00-DR-CU-0051)</p> <p><u>Water</u> None Identified</p> <p><u>Gas</u> Proximity to GNI low pressure gas asset running parallel - to be retained (see drawing BCIDB-JAC-UTL_UG-0013_XX_00-DR-CU-0051)</p> <p><u>Data</u> Proximity to EIR cabling running parallel - to be diverted to run parallel approx. 1m from wall (see</p>	<p>Overhead low voltage ESB - to be diverted to run alongside wall (see drawing BCIDB-JAC-UTL_UX-0013_XX_00-DR-CU-0051)</p>

	drawing BCIDB-JAC-UTL_UX-0013_XX_00-DR-CU-0051)	
R13-RW017	<p><u>Electricity</u> None Identified</p> <p><u>Water</u> Proximity to a 100mm dia. water main running parallel - to be diverted to run parallel 1.5m from wall at southern end (see drawing BCIDB-JAC-UTL_UW-0013_XX_00-DR-CU-0051)</p> <p><u>Gas</u> Proximity to GNI low pressure gas asset running parallel - to be diverted to run parallel approx. 3m from wall at southern end - to be retained (see drawing BCIDB-JAC-UTL_UG-0013_XX_00-DR-CU-0051)</p> <p><u>Data</u> Proximity to EIR cabling running parallel - to be diverted to run parallel approx. 1m from wall (see drawing BCIDB-JAC-UTL_UX-0013_XX_00-DR-CU-0051)</p>	Overhead low voltage ESB - to be diverted to run alongside wall (see drawing BCIDB-JAC-UTL_UX-0013_XX_00-DR-CU-0051)
Utilities list does not include domestic / privately owned services and supplies for street furniture		

Table 2.7: Summary of existing services

2.8 Geotechnical Summary

A geotechnical desktop study of the area has been undertaken using publicly available information and Ground Investigation reports available through the Geological Survey of Ireland. Where identified, supplementary GI information was requested to increase the understanding of the geological conditions at targeted locations across the scheme.

Refer to Section 7 for details of the ground conditions at each retaining wall location.

2.9 Hydrology and Hydraulic Summary

Construction of the retaining walls on this scheme is not expected to have any significant impact on the local hydrogeology.

2.10 Archaeological Summary

There is no impact envisaged from these structures.

2.11 Environmental Summary

An Environmental Impact Assessment (EIA) is currently being prepared for the scheme on behalf of the Employer. Outcomes from this EIA will be reviewed and incorporated once determined.

3. Structure & Aesthetics

3.1 General Description of Recommended Structure and Design Working Life

A preferred option for each wall has been recommended based on the evaluation of the site-specific constraints.

Wall Reference	Preferred Wall Solution
R13-RW023	Cast In-Situ Concrete Gravity Wall
R13-RW024	Precast Concrete Retaining Wall
R13-RW036	Precast Concrete Retaining Wall
R13-RW038	Precast Concrete Retaining Wall
R13-RW013	Precast Concrete Retaining Wall
R13-RW016	Cast In-Situ Concrete Gravity Wall
R13-RW017	Cast In-Situ Concrete Gravity Wall

Table 3.1: Summary of preferred options

3.1.1 R13-RW023

The proposed wall is required to retain the land owned by the school at a height of 2m for approximately 35m length, to accommodate a new widened footpath and cycle lane.

Cast in-situ concrete gravity wall is the preferred option at this location due to the wall's complex geometry and reduced risk posed by overhead cabling. This solution will more easily match the required geometry proposed by the new highway alignment, while present a more appealing surface due to the lack of vertical joints.

The installation of cast in-situ concrete walls presents similar challenges to that found in the precast cantilever wall option with respect to the need for temporary slopes to facilitate construction. In-situ concrete walls require a stable base to be founded upon, which would need the removal and replacement of topsoil/made ground with engineered fill.

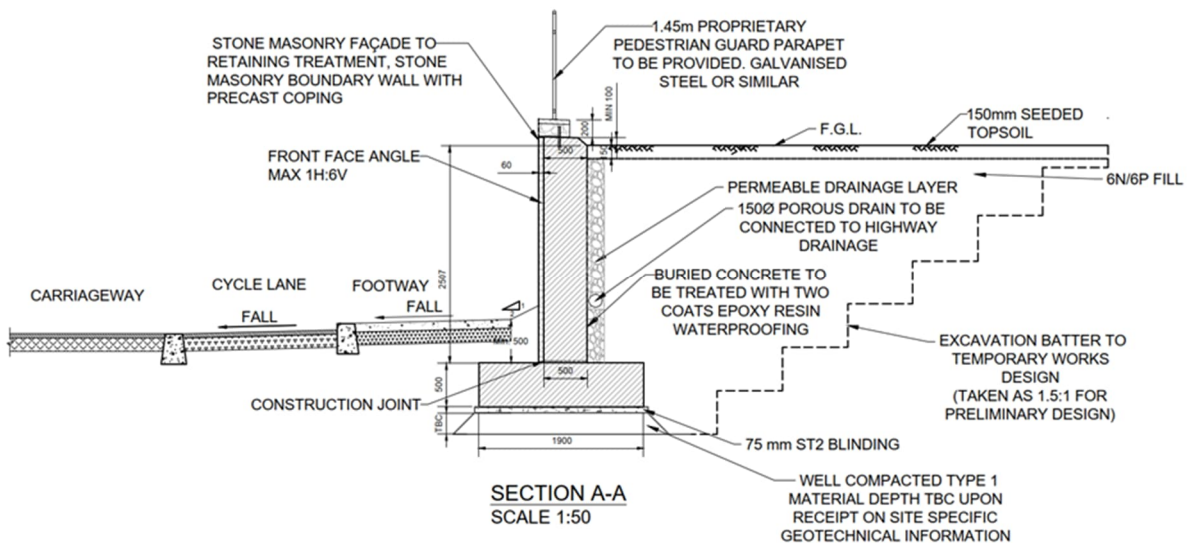

Figure 3.1.1: R13-RW023 Typical Cross-Section

3.1.2 R13-RW024

The proposed wall is required to support the new bus lane and widened footpath. The wall must be capable of supporting a traffic surcharge and retain a height varying between 1m-2m for approx. 40m length.

A precast concrete retaining wall will provide sufficient resistance against destabilising forces through the weight of soil acting on the heel of the wall. These are commonly used for heights up to 3m, limited by craneage constraints at greater heights.

Precast concrete retaining wall is the preferred option at this location as it avoids on-site casting processes, offering a quicker and less disruptive construction timeline. This solution provides an environmentally friendly solution.

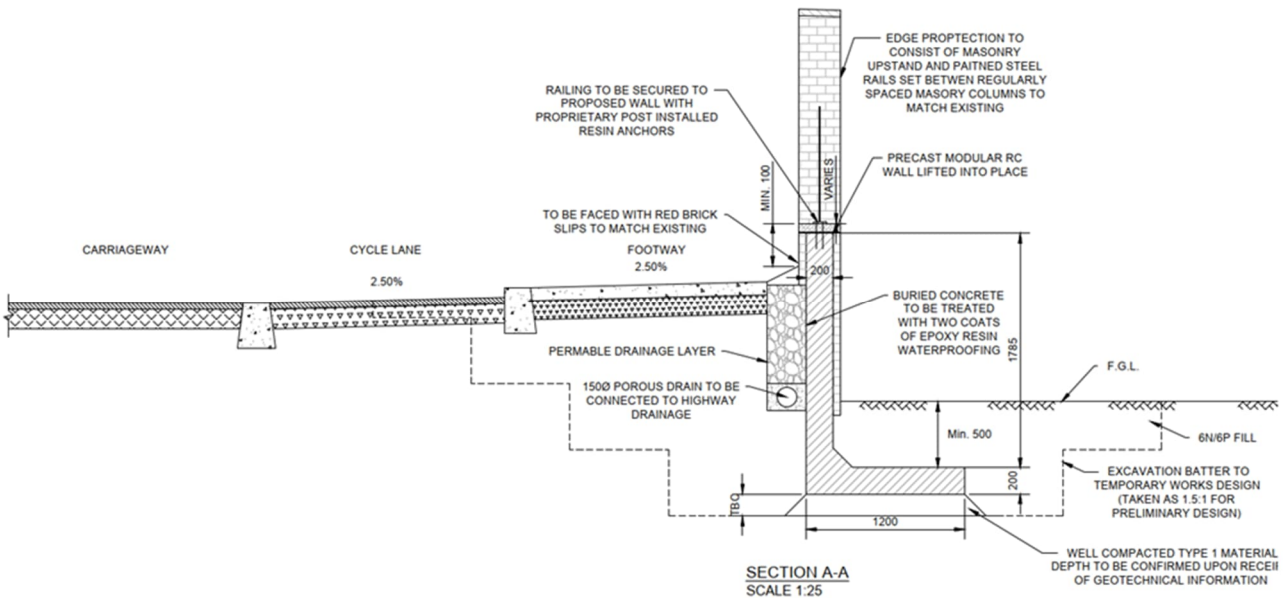

Figure 3.1.2: R13-RW024 Typical Cross-Section

3.1.3 R13-RW036

The proposed wall is required to retain privately owned land to accommodate the highway widening, including a cycle lane and widened footpath.

A precast concrete retaining wall will provide sufficient resistance against destabilising forces through the weight of soil acting on the heel of the wall. These are commonly used for heights up to 3m, limited by craneage constraints at greater heights.

Precast concrete retaining wall is the preferred option at this location as it avoids on-site casting processes, offering a quicker and less disruptive construction timeline. This solution provides an environmentally friendly solution.

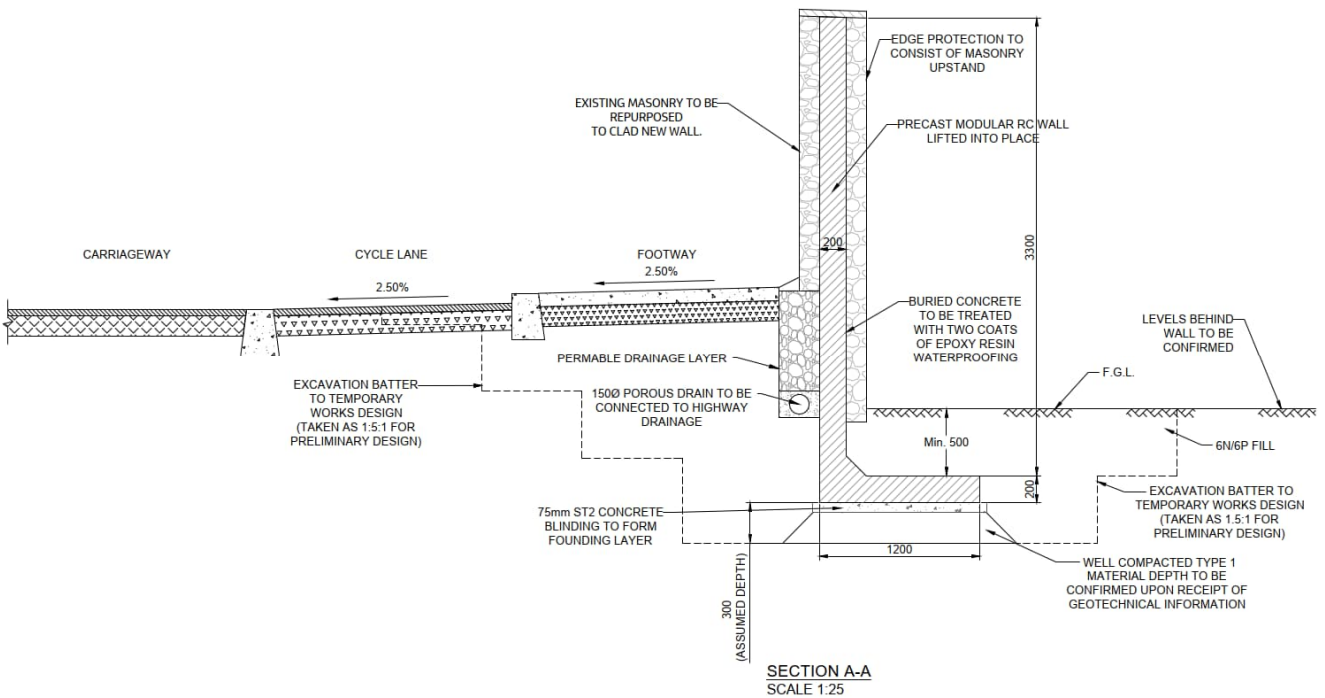
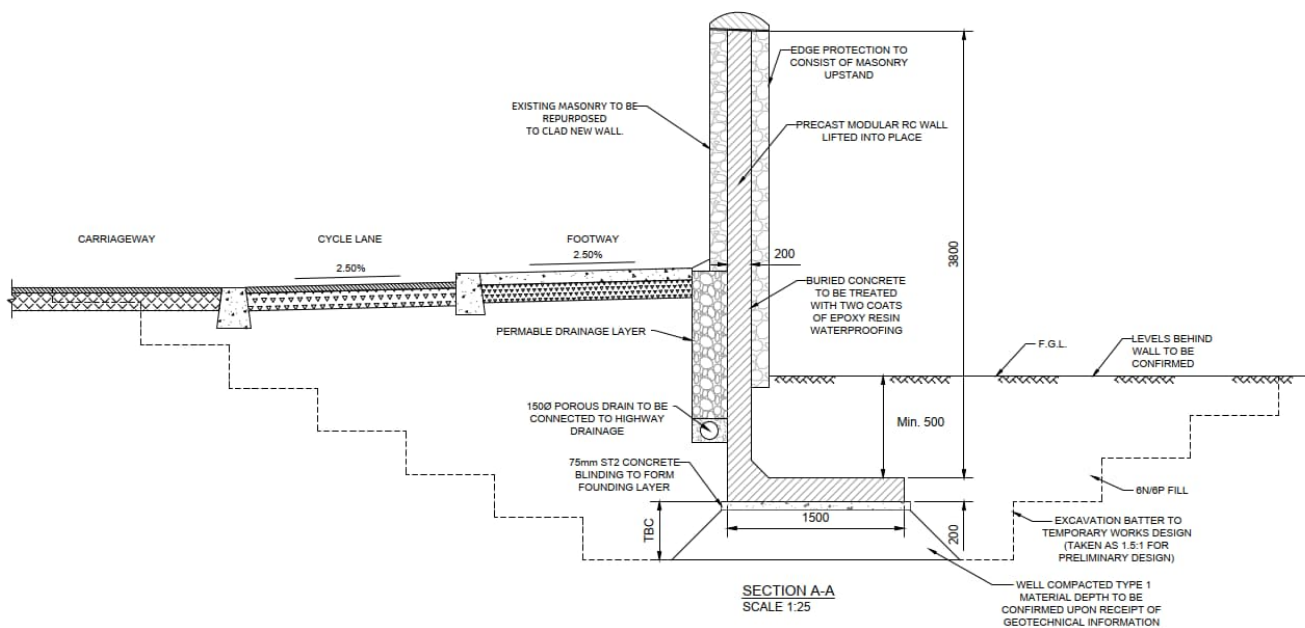

Figure 3.1.3: R13-RW036 Typical Cross-Section

3.1.4 R13-RW038

The proposed wall must be capable of resisting pedestrian surcharge and accidental wheel loads and is expected to measure 1.8m in height and 40m in length.

The existing stone masonry wall was identified by heritage specialists as possessing significant importance due to its age and prominence in the local area. The precast concrete retaining wall is the preferred structural solution as it is the least expensive and fastest to construct, minimising disruption to local traffic and access to the golf club and lodge. This option can be faced with stone masonry to tie into adjacent walls, replicating the original wall. Stone copings should be placed on the new section to match the existing to help retain the character of the road.



The precast concrete retaining wall is the preferred solution as it retains tangible historic heritage while being the quickest to construct with the least associated risk.

Figure 3.1.4: R13-RW038 Typical Cross-Section

3.1.5 R13-RW013

The proposed wall must be capable of resisting pedestrian surcharge and accidental wheel loads. This is expected to have a retained height of 1.5m and a length of 100m.

The existing stone masonry wall was identified by heritage specialists as possessing significant importance due to its age and prominence in the local area. The precast concrete retaining wall is the preferred structural solution as it minimises construction time on a wall of this length, while having lower associated risk for construction operatives. This solution allows the new structure to complement the old, maintaining the cultural heritage of the local area.

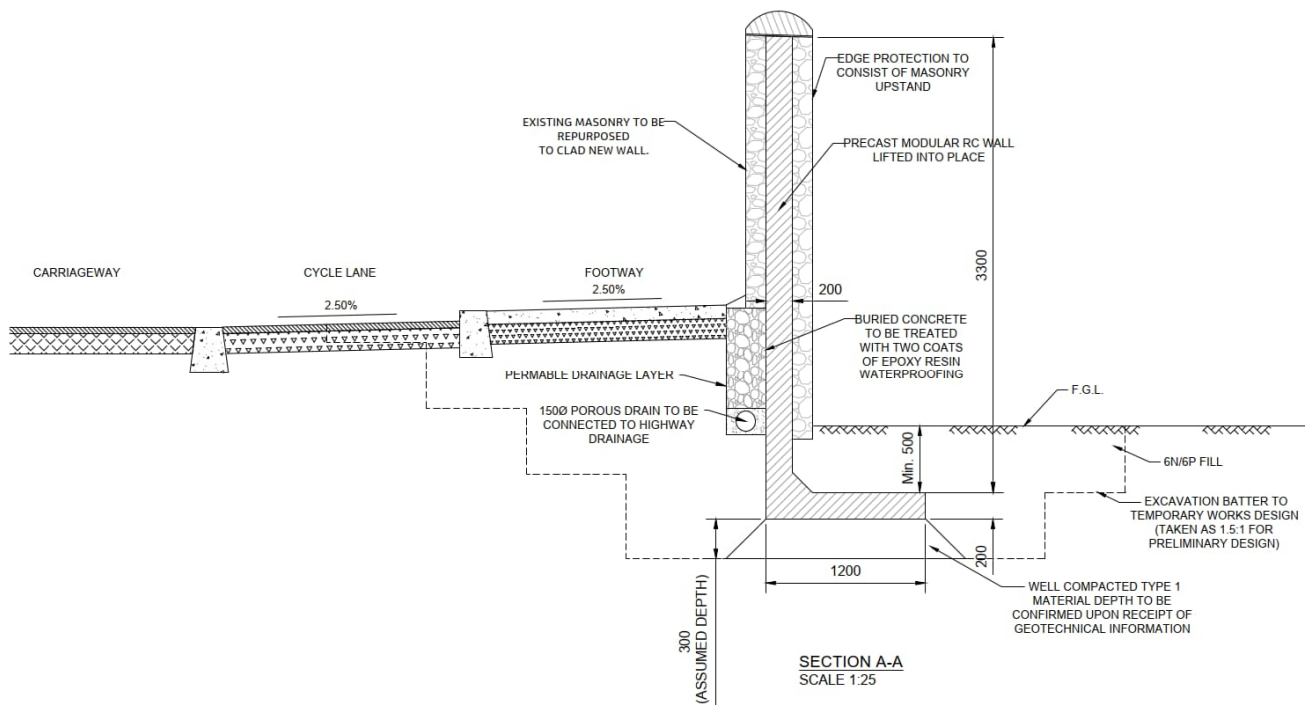

Figure 3.1.5: R13-RW013 Typical Cross-Section

3.1.6 R13-RW016

The proposed wall is expected to retain a height of 2.5m along a length of approx. 45m.

Cast in-situ concrete gravity wall is the preferred option at this location as it offers easier construction of the required curved geometry while also reducing risk associated with overhead utilities during construction

The existing rendered wall was identified by heritage specialists as possessing significant importance in the area. The new alignment necessitates the demolition of a section of the wall. Therefore, it is recommended that the character of this historical section of wall is maintained. The new structure comprising of in-situ concrete shall aim to replicate/complement the general geometry of the wall with particular focus on the curvature of the entrance and the panelled nature of the boundary wall.

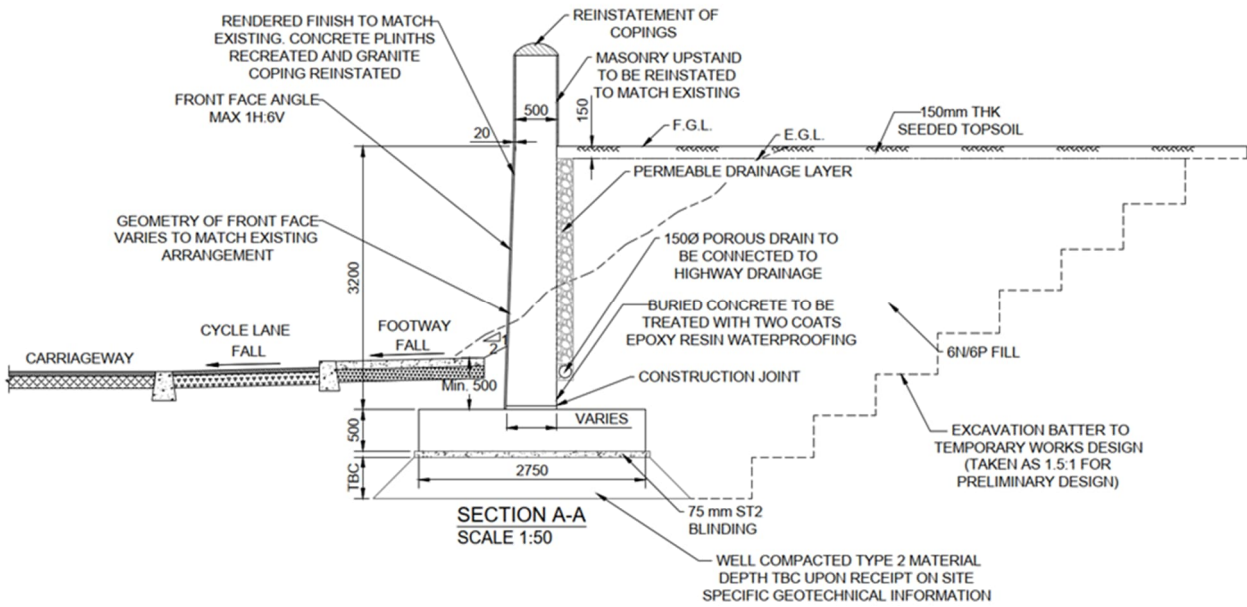

Figure 3.1.6: R13-RW016 Typical Cross-Section

3.1.7 R13-RW017

The proposed wall is required to retain the new highway alignment of a bus lane, cycle lane and footway, and will support a traffic surcharge loading. The wall must retain a height between 1m-2m along a length of approximately 40m.

Cast in-situ concrete gravity wall is the preferred option at this location as it presents a lower risk of damaging the tree and will be able to tie into the existing wall without appearing out of place.



Figure 3.1.7a: Image of north end of R13-RW017 and the Monterey Pine Tree to be retained

The existing rendered wall was identified by heritage specialists as possessing significant importance in the area. Therefore, it is recommended that the character of this historical section of wall be maintained. The wall shall be constructed in a similar way to R13-RW016, with an in-situ concrete wall to replicate the geometry. The wall shall provide continuity with wall R13-RW016 and nearby properties which also favour rendered finishes.

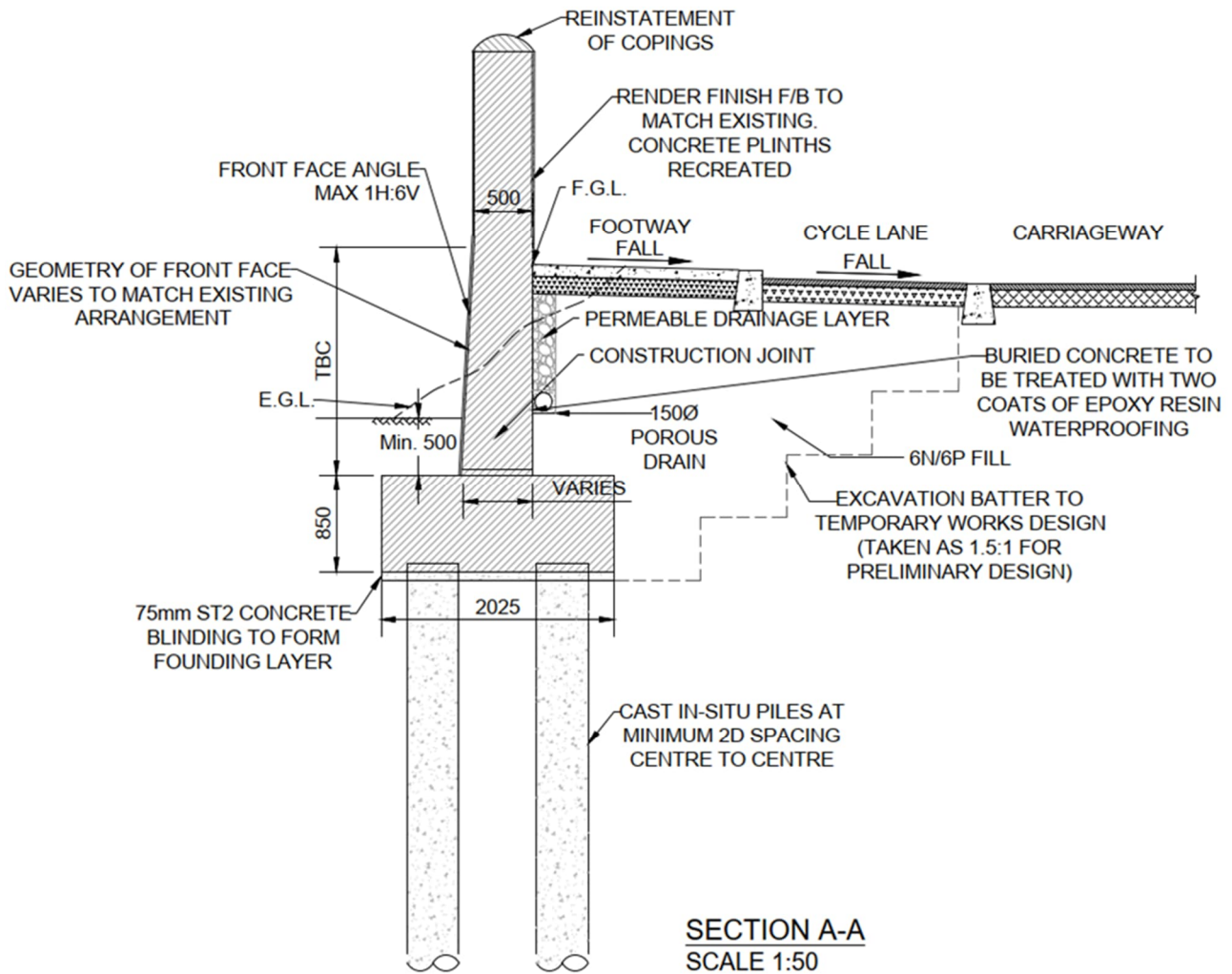

Figure 3.1.7b: R13-RW017 Typical Cross-Section

3.2 Aesthetic Considerations

For each of the locations the proposed solution should take into consideration the visual impact on the environment. There are no contractually specified finishes for walls however care should be taken to match existing finishes, in both the immediate locality and on the route in general. Thought should be given to use of feature finishes to break up plain vistas and to improve the visual appearance at locations which present a large exposed front face to the public.

3.2.1 R13-RW023

The cast in-situ concrete option has a similar visual appearance to that of the precast option described below. Through the choice of formwork, a variety of finishes can be achieved immediately following strike off or a rendered finish can be applied after the concrete has been cast. It is typical of these types of structures to have a battered front face to make the form more efficient. This would help the wall appear less stark by avoiding the drastic changes in vertical alignments.

3.2.2 R13-RW024 & R13-RW036

An economical option for the precast concrete wall solution is the use of precast concrete panels incorporating a vertical groove feature. The joints between panels also create a featured finish, which breaks up the appearance of the otherwise plain walls.

3.2.3 R13-RW038 & R13-RW013

The existing stone masonry wall was identified by heritage specialists as possessing significant importance due to its age and prominence in the local area. The existing wall consisting of granite and limestone rubble course materials should be recorded, carefully demolished with selections from the site won material repurposed to form a facing for the new concrete structure. The original coping elements should be re-used where practical. Any additional materials required should be procured as like for like replacement and construction should be carried out in accordance with conservation construction practices when using contemporary materials.

The design intent is to provide a well-detailed structure that complements the existing historical walls and local surroundings.

3.2.4 R13-RW016

Rendered boundary wall with granite copings belonging to the historic Ravenswell House. Effort should be made to retain this local feature where practical.

The existing rendered wall was identified by heritage specialists as possessing significant importance in the area. A smooth sandstone coloured render should be applied to the entrance section to complement the existing finish to the wall and pilaster. The pebbledash finish on the panelled section holds no significant heritage value and is not in keeping with the local environment, therefore it is proposed that the panels be replicated to retain the character of the wall but with a smooth sandstone coloured render reinstated to complement the entrance to Ravenswell House and improve continuity with nearby properties that also favour rendered finishes.

A concrete plinth should be provided at the base of the wall below the level of the panels to reflect the existing character of the wall and to protect the render against water incursion. Existing granite copings should be re-used on the newly constructed section forming the entrance. The pilasters to which the iron gates are attached should be reinstated using their original construction materials as there is no requirement for this part of the wall to act structurally. All ironwork fixings including the gates, light fixings, and plaques should be removed, refurbished and reinstated on the new wall. Thought should be given to the inclusion of granite copings along this section to further improve the visual continuity of this prominent boundary wall.

Additional materials required should be procured on a like for like replacement and construction should be carried out in accordance with conservation construction practices using contemporary materials.

3.2.5 R13-RW017

Rendered boundary wall with granite copings belonging to the historic Ravenswell House. Effort should be made to retain this local feature where practical.

A new sandstone coloured render should be applied to complement the existing finish to the wall and pilaster, and panels replicated to retain the character of the wall, using concrete plinths and existing granite copings. The retained sections of the wall should be refurbished such that there is not an obvious difference in appearances to the surrounding newly constructed walls. The pilasters, all ironwork fixings including the gates, light fixings, and plaques should be removed, refurbished and reinstated on the new wall. Additional materials required should be procured on a like for like replacement and construction should be carried out in accordance with conservation construction practices using contemporary materials.

The wall shall provide continuity with wall R13-RW016 and nearby properties which also favour rendered finishes.

3.3 Proposals for the Recommended Structure

3.3.1 Proposed Category

The retained height of all the walls is smaller than 5m, hence the walls are classified as Category 1 structures in accordance with DN-STR-03001.

3.3.2 Span Arrangement

Not applicable.

3.3.3 Minimum Headroom Provided

Not applicable.

3.3.4 Approaches including run-on arrangements

Not applicable.

3.3.5 Foundation Type

If the precast concrete retaining walls (R13-RW024, R13-RW036, R13-RW029, R13-RW038, R13-RW013) comprise of modular systems then there is no requirement for additional foundations and can be placed directly atop a suitably prepared layer of compacted unbound fill.

If the precast concrete retaining walls (R13-RW024, R13-RW036, R13-RW029, R13-RW038, R13-RW013) comprise of a bolt down wall system then there is necessary to lift the wall sections onto a reinforced concrete foundation.

A pile foundation is proposed for the in-situ reinforced wall at R13-RW017 due to the large depth of made ground encountered at this location to avoid large excavation requirements.

3.3.6 Substructure

Not applicable.

3.3.7 Superstructure

Not applicable.

3.3.8 Articulation Arrangement

Nominal 20mm vertical movement joints will be used between sections of wall to allow for natural expansion and contraction of the concrete. Stainless steel dowel bars will be used to control differential displacement of the wall sections where deemed necessary.

3.3.9 Vehicle Restraint System

Where walls present a hazard within the clear zone, a Vehicle Restraint System (VRS) will be provided in accordance with DN-REQ-03034.

3.3.10 Drainage

A permeable drainage layer will be provided behind the in-situ concrete retaining walls in accordance with CC-SPW-00500 and will provide positive outfall from one end to the other of the structure and will connect to the mainline road drainage.

3.3.11 Durability

The structure will comprise reinforced concrete, which is a highly durable material with a working design life of 120 years (Working Life Category 5) for the structure. Concrete specification and cover to reinforcement will be in accordance with TII publication DN-STR-03012 (Design for Durability).

3.3.12 Sustainability

Recycled GGBS will be used in the design and construction of some of the concrete elements of the structure leading to a more sustainable structure overall.

3.3.13 Inspection and Maintenance

The proposed structures are of reinforced concrete construction. It is expected that the structure will have minimal maintenance and inspection requirements.

4. Safety

4.1 Traffic Management during construction

To be developed at a further stage of the design.

4.2 Safety during construction

The Designer will take account of the General Principles of Prevention, as specified in the Schedule 3 of the Safety, Health and Welfare at Work Act 2005, liaise with the Project Supervisor appointed by the Client for the Design Process and the Project Supervisor appointed for the Construction Stage and carry out all other duties as required by Clause 15 of the Safety, Health and Welfare at Work (Construction) Regulations 2013 (S.I. No. 291 of 2013).

4.3 Safety in use

No Vehicle Restraint Systems are proposed along any of the walls. Pedestrian parapets and protection barriers shall be provided as appropriate in accordance with TII Publication DN-REQ-03034.

4.4 Lighting

There are no lighting requirements for these structures.

5. Design Assessment Criteria

5.1 Actions

5.1.1 Permanent Actions

Permanent actions in accordance with IS EN 1991-1-1:2002 and the associated National Annex.

5.1.2 Snow, Wind and Thermal Actions

Snow actions are not considered in the design of the retaining walls. Snow load is ignored in accordance with NA to IS EN 1990:2002.

Wind actions shall be in accordance with IS EN 1991-1-4 and the associated National Annex.

Thermal actions will be assessed in accordance with IS EN 1991-1-5 and the associated National Annex.

5.1.3 Actions Relating to Normal Traffic

The application of traffic loads and distribution through the soil will be applied to the retaining walls in accordance with PD 6694-1:2011 (*Recommendations for the design of structures subject to traffic loading to BS EN 1997-1:2004*).

5.1.4 Actions Relating to Abnormal Traffic

Not applicable.

5.1.5 Footway or Footbridge Live Loading

Not applicable.

5.1.6 Provision for Exceptional Abnormal Loads

Abnormal loads not considered, subject to TAA confirmation

5.1.7 Accidental Actions

Pedestrian parapets shall be designed conform to the requirements of PD CEN/TR 16949:2016.

5.1.8 Actions during Constructions

Not applicable.

5.1.9 Any Special Loading not Covered Above

A transient surcharge load will be applied to the ground behind the walls. The following non-concurrent loads have been considered in the design depending on the slope of the ground level behind the wall:

- 10 kPa Construction Surcharge (ground profile level behind the wall)
- 10 kPa Design Surcharge for slopes $\beta \leq 1V:6H$
- 5.0 kPa Design Surcharge for slopes $1V:6H < \beta \leq 1V:3H$
- 2.5 kPa Design Surcharge for slopes $\beta > 1V:3H$

5.2 Authorities consulted and any special conditions required

There are no additional consultations or special conditions for these structures

5.3 Proposed Departures from Standards

There are no proposed departures from standards for these structures

5.4 Proposed methods of dealing with aspects not covered in standards

Not applicable.

6. Ground Conditions

6.1 Geotechnical Classification

Retaining walls for this scheme are considered Geotechnical Classification 2.

6.2 Ground Conditions

Ground conditions at each structure location have been assessed using publicly available information including geological maps, hydrogeological information, publicly available ground investigations and historic mapping. The assumed local geology is described for each wall location below.

6.2.1 R13-RW023

The ground conditions at this location are assumed to comprise Till derived from limestones (Dublin Boulder Clay) overlying bedrock geology of dark blue-grey slate, phyllite and schist of the Maulin Formation. Thickness of superficial deposits are unconfirmed, publicly available borehole information indicate a minimum thickness of 5m. Publicly available GI reports (GSI External Report Refs: [5260](#), [6512](#), [6536](#), Figure 6-1) indicated the superficial geology of the area is generally described as firm to very stiff clay. The retaining walls are expected to be founded on Dublin Boulder Clay.

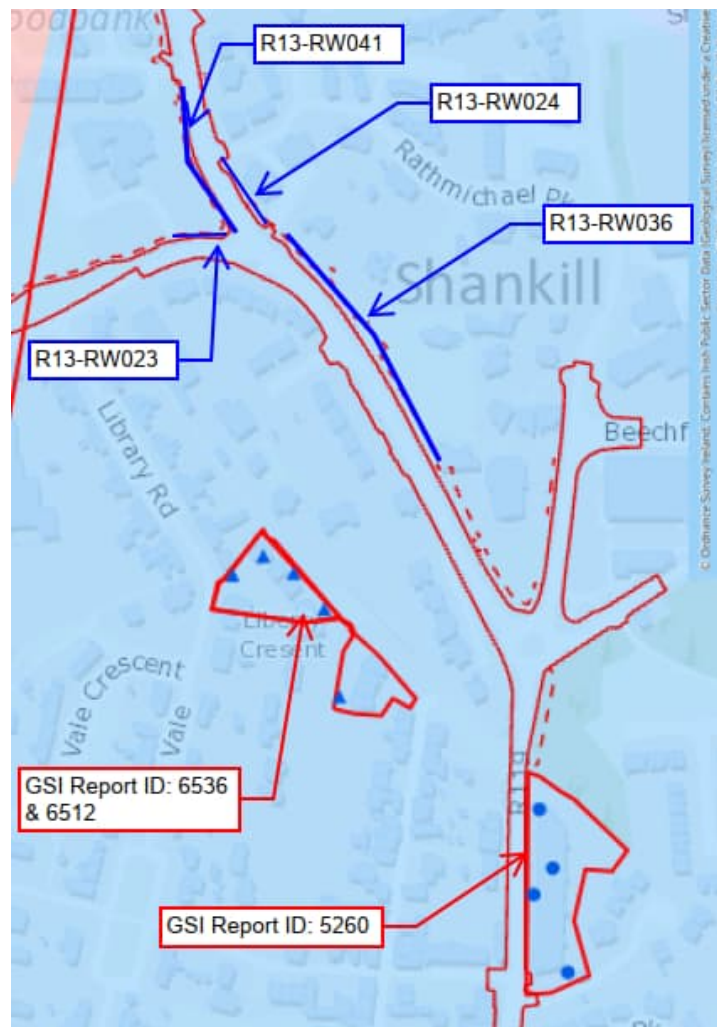

Figure 6-1 Extract of GSI mapping showing location of historical GI.

6.2.2 R13-RW024

The ground conditions at this location are assumed to comprise Till derived from limestones (Dublin Boulder Clay) overlying bedrock geology of dark blue-grey slate, phyllite and schist of the Maulin Formation. Thickness of superficial deposits are unconfirmed, publicly available borehole information indicate a minimum thickness of 5m. Publicly available GI reports (GSI External Report Refs: [5260](#), [6512](#), [6536](#), Figure 6-1) indicated the superficial geology of the area is generally described as firm to very stiff clay. The retaining walls are expected to be founded on Dublin Boulder Clay.

6.2.3 R13-RW036

The ground conditions at this location are assumed to comprise Till derived from limestones (Dublin Boulder Clay) overlying bedrock geology of dark blue-grey slate, phyllite and schist of the Maulin Formation. Thickness of superficial deposits are unconfirmed, publicly available borehole information indicate a minimum thickness of 5m. Publicly available GI reports (GSI External Report Refs: [5260](#), [6512](#), [6536](#) Figure 6-1) indicated the superficial geology of the area is generally described as firm to very stiff clay. The retaining walls are expected to be founded on Dublin Boulder Clay.

6.2.4 R13-RW038

The ground conditions at this location are assumed to comprise Irish Sea Till derived from limestones and gravels derived from limestones overlying bedrock geology of dark blue-grey slate, phyllite and schist of the Maulin Formation. Thickness of superficial deposits are unconfirmed, publicly available borehole information indicate a minimum thickness of 20m. Publicly available GI reports (GSI External Report Refs: [1766](#), [6914](#), [7003](#) Figure 6-1) indicated the superficial geology of the area is generally described as firm to very stiff clay with medium dense sand gravel strata also recorded within boreholes to the northeast and west of the proposed structure. The retaining walls are expected to be founded on Irish Sea Glacial Till or gravels derived from limestones.

6.2.5 R13-RW013

The ground conditions at this location are assumed to comprise gravels derived from limestones and Irish Sea Till derived from limestones overlying bedrock geology of dark blue-grey slate, phyllite and schist of the Maulin Formation. Thickness of superficial deposits are unconfirmed, publicly available borehole information indicate a minimum thickness of 20m. Publicly available GI reports (GSI External Report Refs: [1766](#), [6914](#), [7003](#), Figure 6-1) indicated the superficial geology of the area is generally described as firm to very stiff clay with medium dense sand gravel strata also recorded within boreholes to the northeast and west of the proposed structure. The retaining walls are expected to be founded on Irish Sea Glacial Till or gravels derived from limestones.

6.2.6 R13-RW016

The ground conditions at R2-RW016 were assessed in windowless sampling borehole R13-WS01 of Bus Connects Route 13 Bray to City Centre – Ground Investigation (Appendix B). The results of the ground investigation indicate the ground conditions are comprised of soft to firm sandy, gravelly silt overlying medium dense sandy, silty gravel. The borehole terminated in dense gravel at 2.0m bgl. R13-CP03 located at R13-RW017 indicated a greater thickness (2m) of silt overlying medium dense gravel and sand. Bedrock geology underlying the site is dark blue-grey slate, phyllite and schist of the Maulin Formation. The retaining walls are expected to be founded on medium dense gravel.

6.2.7 R13-RW017

The ground conditions at R2-RW017 were assessed in windowless sampling borehole R13-CP03 of Bus Connects Route 13 Bray to City Centre – Ground Investigation (Appendix B). The results of the ground investigation indicate the ground conditions at the structure consist of 3.5m of made ground comprising sandy, silty gravel and very soft to soft sandy, gravelly clay. The stratigraphy of natural strata underlying the made ground is comprised of very stiff silt and dense gravel overlying dense sand.

It has been interpreted that the made ground was placed to level the site which naturally falls away into a valley to the north of the location. It is recommended that the made ground underlying the structure should be excavated and replaced with a suitable engineering fill.

7. Drawings and Documents

7.1 List of All Documents Accompanying the Submission

Drawing Reference	Drawing Title	Revision
BCIDB-JAC-STR_GA-0013_RW_00-DR-CB-1001	Site Location Plan	M01
BCIDB-JAC-STR_GA-0013_RW_00-DR-CB-1101	General Arrangement R13-RW023	M01
BCIDB-JAC-STR_GA-0013_RW_00-DR-CB-1102	General Arrangement R13-RW023	M01
BCIDB-JAC-STR_GA-0013_RW_00-DR-CB-1103	General Arrangement R13-RW036	M01
BCIDB-JAC-STR_GA-0013_RW_00-DR-CB-1104	General Arrangement R13-RW013	M01
BCIDB-JAC-STR_GA-0013_RW_00-DR-CB-1105	General Arrangement R13-RW038	M01
BCIDB-JAC-STR_GA-0013_RW_00-DR-CB-1108	General Arrangement R13-RW016	M01
BCIDB-JAC-STR_GA-0013_RW_00-DR-CB-1109	General Arrangement R13-RW017	M01

Table 7.1.1: List of accompanying drawings

Appendix A. **Drawings**

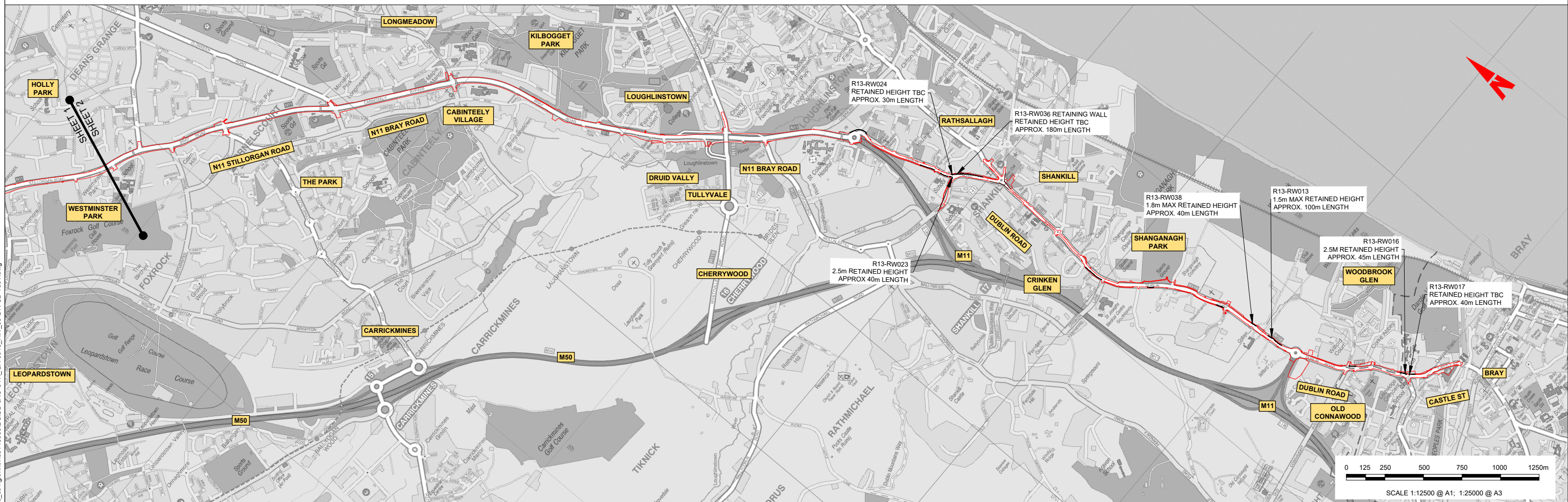
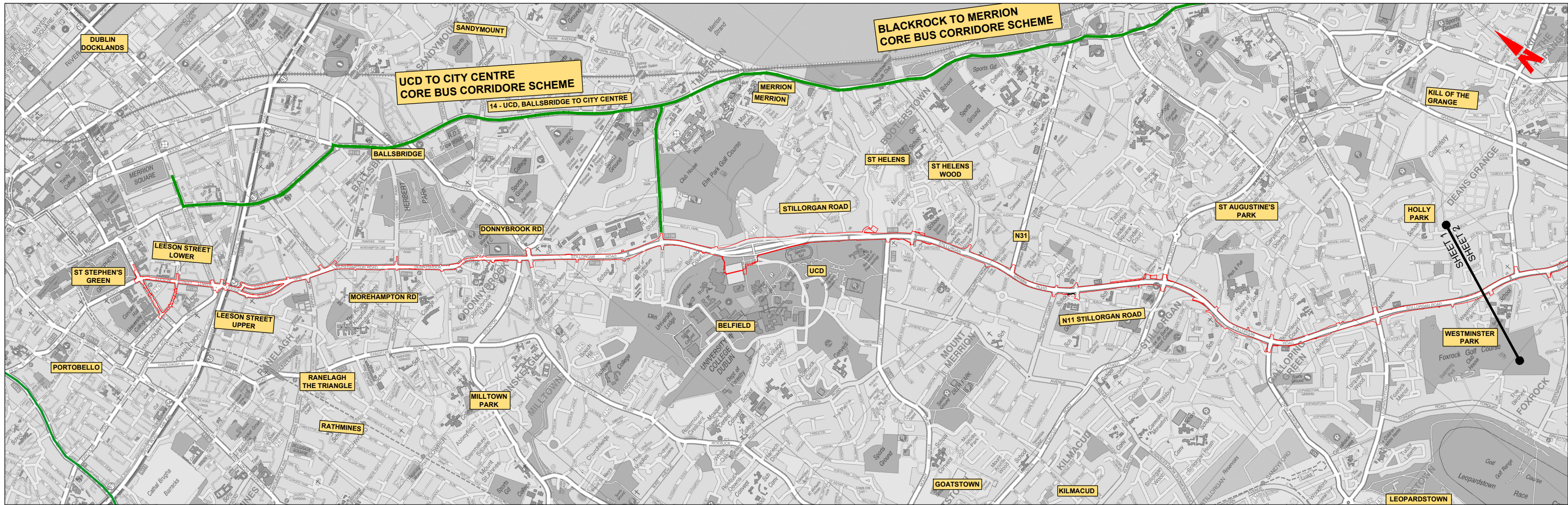

Disclaimer
 a. © National Transport Authority (NTA) 2022. This drawing is confidential and the copyright in it is owned by NTA. This drawing must not be either loaned, copied or otherwise reproduced in whole or in part or used for any purpose without the prior permission of NTA.
 b. This drawing is to be used for the design element identified in the titleblock. Other information shown is to be considered indicative only. The drawing is to be read in conjunction with all other relevant design drawings.
 c. O.S. data used for plans are printed under © Ordnance Survey Ireland Government of Ireland. All rights reserved. Licence Number 2022/OS_NMA_180 National Transport Authority. All elevations are in metres and relate to OS Grid Model (OSGM15) Mean Head. All Co-ordinates are in Irish Transverse Mercator Grid (ITM) as defined by OSI active local GPS station.
 d. Information concerning the position of apparatus shown on this drawing is based on drawings supplied by the utility owners and/or the utility works contractor, whilst every care has been taken in the preparation of this drawing, positions should be taken as approximate and are intended for general guidance only and no representation is made by the NTA as to the accuracy, completeness, sufficiency or otherwise of this drawing and/or the position of the apparatus. The information contained herein does not purport to be comprehensive or final as the apparatus is subject to being altered and/or superseded. Recipients should not rely on this information. Any liabilities are hereby expressly disclaimed.

The information contained herein has been provided by the NTA but does not purport to be comprehensive or final. Recipients should not rely on the information. Neither the NTA nor any of its directors, officers, employees, agents, stakeholders or advisers make any representation or warranty as to, or accept any liability or responsibility in relation to, the adequacy, accuracy, reasonableness or completeness of the information provided as part of this document or any matter on which the information is based (including but not limited to loss or damage arising as a result of reliance by recipients on the information or any part of it). Any liabilities are hereby expressly disclaimed.

Project Ireland 2040
 Building Ireland's Future

Rev	Date	Drn	Chk'd	App'd	Description
M01	27/01/2023	RG	JM	RS	ISSUE FOR PHASE 4: PLANNING

Client: **NTA**
 Údarás Náisiúnta Iompair
 National Transport Authority

Engineering Designer: **Jacobs**

Date	Scale	NTS @ A1	Drawn	Checked	Approved
27/01/2023	NTS @ A3	RG	JM	RS	
Project Code	Originator Code	QMS Code			
BCIDB	JAC				

Programme Title: **BUSCONNECTS DUBLIN CORE BUS CORRIDORS INFRASTRUCTURE WORKS**

Drawing Title: **BRAY TO CITY CENTRE SCHEME RETAINING WALLS SITE LOCATION PLAN**

Drawing File Name	Sheet Number	Status	Rev
BCIDB-JAC-STR_GA-0013_RW_00-DR-CB-1001	01 of 1	A	M01

DO NOT SCALE USE FIGURED DIMENSIONS ONLY

- NOTES:**
- ALL DIMENSIONS ARE SHOWN IN MILLIMETRES UNLESS NOTED OTHERWISE.
 - ALL LEVELS ARE SHOWN IN METRES ABOVE ORDINANCE OSI GEIOD MODEL (OSGM15) MALIN HEAD.
 - FINISHES:
 - BURIED UNFORMED SURFACES -U1
 - BURIED FORMED SURFACES -F1
 - EXPOSED UNIFORM SURFACES (EXCLUDING AREA TO BE WATERPROOFED) -U3
 - ALL OTHER EXPOSED FORMED SURFACED -F4
 - MATERIALS:
 - LOCATION: CONCRETE GRADE: -C32/40 (50% GGBS)
 - RETAINING WALLS
 - NON-STRUCTURAL CONCRETE: CONCRETE GRADE: -ST2
 - LOCATION: CONCRETE FOR BLINDING
 - BURIED CONCRETE SURFACES SHALL BE TREATED WITH TWO COATS OF EPOXY RESIN WATERPROOFING PAINT IN ACCORDANCE WITH TII CC-SPW-01700.
 - ALL EXPOSED CONCRETE SHALL BE IMPREGNATED WITH A HYDROPHOBIC PORE LINER IN ACCORDANCE WITH THE TII CC-SPW-01700.
 - EXTERNAL CONCRETE ARISES TO BE CHAMFERED 25x25 UNLESS NOTED OTHERWISE.
 - STONE MASONRY FACING TO BE ANCHORED TO RETAINING WALL USING ANCON POST FIXED STAFFIX UNIVERSAL WALL STARTER SYSTEM AND S021 125MM WALL TIES OR EQUIVALENT AT 600MM STAGGERED HORIZONTAL AND VERTICAL CENTRES.
 - LOCALISED SOFT SPOTS, IF PRESENT, TO BE EXCAVATED AND REPLACED WITH 6N/6P.
 - NOMINAL MOVEMENT JOINTS TO BE AT 10M SPACING.



PLAN ON RETAINING WALL
SCALE 1:250

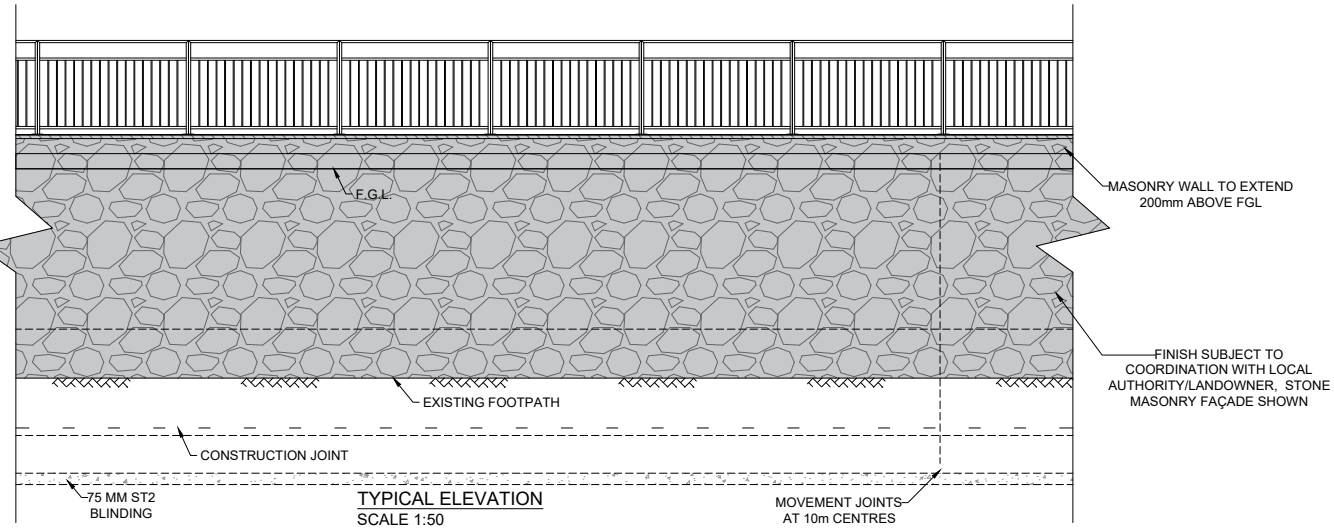

TYPICAL ELEVATION
SCALE 1:50

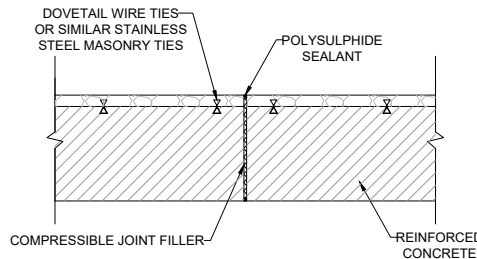

TYPICAL CROSS SECTION THROUGH WALL JOINT
SCALE 1:20

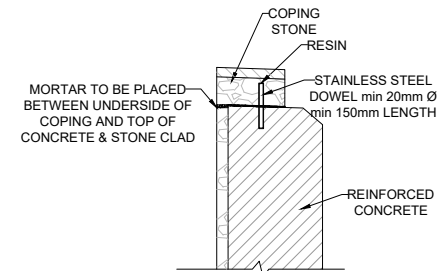

CROSS SECTION THROUGH COPING STONE TIE IN
SCALE 1:20

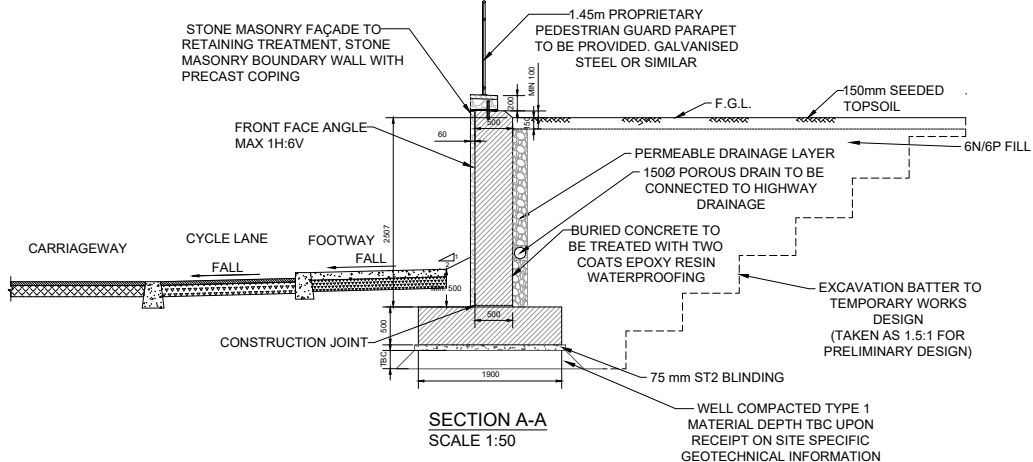

SECTION A-A
SCALE 1:50

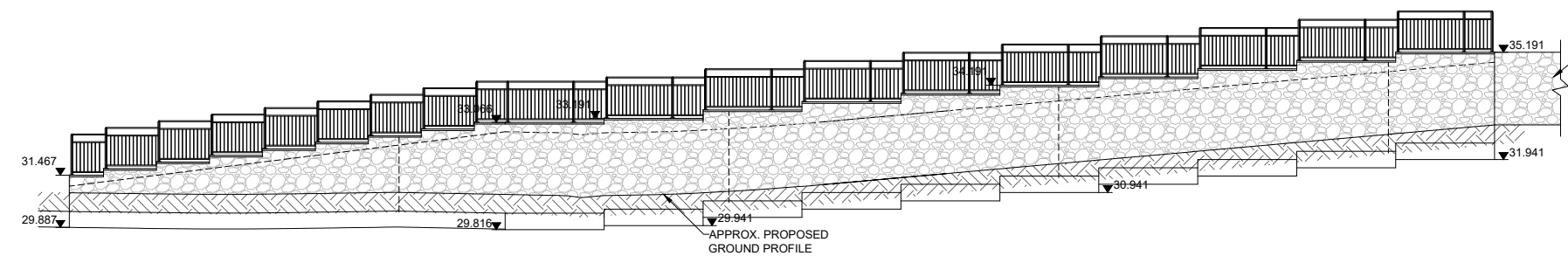

DEVELOPED FRONT ELEVATION
SCALE 1:100

PROPOSED WALL TO TIE INTO EXISTING. EXISTING WALL TO BE SAW CUT TO PROVIDE A VERTICAL INTERFACE. 20mm COMPRESSION BOARD TO BE PLACED BETWEEN STRUCTURES AND PROPOSED WALL CAST. JOINT SEALANT TO BE PROVIDED ONCE FAÇADE IS IN PLACE

C:\pwworking\jacobs_uk_highways_ssa4\glennor\01486968\BCIDB-JAC-STR_GA-0013_RW_00-DR-CB-1101.dwg

Disclaimer:

a. © National Transport Authority (NTA) 2022. This drawing is confidential and the copyright in it is owned by NTA. This drawing must not be either loaned, copied or otherwise reproduced in whole or in part or used for any purpose without the prior permission of NTA.

b. This drawing is to be used for the design element identified in the titleblock. Other information shown is to be considered indicative only. The drawing is to be read in conjunction with all other relevant design drawings.

c. O.S. data used for plans are printed under © Ordnance Survey Ireland Government of Ireland. All rights reserved. Licence Number 2022/OS_NMA_180 National Transport Authority. All elevations are in metres and relate to OSI Geoid Model (OSGM15) Malin Head. All Co-ordinates are in Irish Transverse Mercator Grid (ITM) as defined by OSI active local GPS station.

d. Information concerning the position of apparatus shown on this drawing is based on drawings supplied by the utility owners and/or the utility works contractor, whilst every care has been taken in the preparation of this drawing, positions should be taken as approximate and are intended for general guidance only and no representation is made by the NTA as to the accuracy, completeness, sufficiency or otherwise of this drawing and the position of the apparatus. The information contained herein does not purport to be comprehensive or final as the apparatus is subject to being altered and/or superseded. Recipients should not rely on this information. Any liabilities are hereby expressly disclaimed.

e. The information contained herein has been provided by the NTA but does not purport to be comprehensive or final. Recipients should not rely on the information. Neither the NTA nor any of its directors, officers, employees, agents, stakeholders or advisers make any representation or warranty as to, or accept any liability or responsibility in relation to, the adequacy, accuracy, reasonableness or completeness of the information provided as part of this document or any matter on which the information is based (including but not limited to loss or damage arising as a result of reliance by recipients on the information or any part of it). Any liabilities are hereby expressly disclaimed.



Rev	Date	Drn	Chk'd	App'd	Description
M01	27/01/2023	RG	JM	RS	ISSUE FOR PHASE 4: PLANNING

Client: **NTA**
Údarás Náisiúnta Iompair
National Transport Authority

Engineering Designer: **Jacobs**

Date: 27/01/2023
Project Code: BCIDB
Originator Code: JAC

Scales shown @ A1 as shown @ A3
Drawn: RG
Checked: JM
Approved: RS

QMS Code

Programme Title: BUSCONNECTS DUBLIN CORE BUS CORRIDORS INFRASTRUCTURE WORKS			
Drawing Title: BRAY TO CITY CENTRE SCHEME DUN LAOGHAIRE RATHDOWN COUNTY COUNCIL GENERAL ARRANGEMENT R13-RW023 RETAINING WALL			
Drawing File Name: BCIDB-JAC-STR_GA-0013_RW_00-DR-CB-1101	Sheet Number: 01 of 1	Status: A	Rev: M01

DO NOT SCALE USE FIGURED DIMENSIONS ONLY

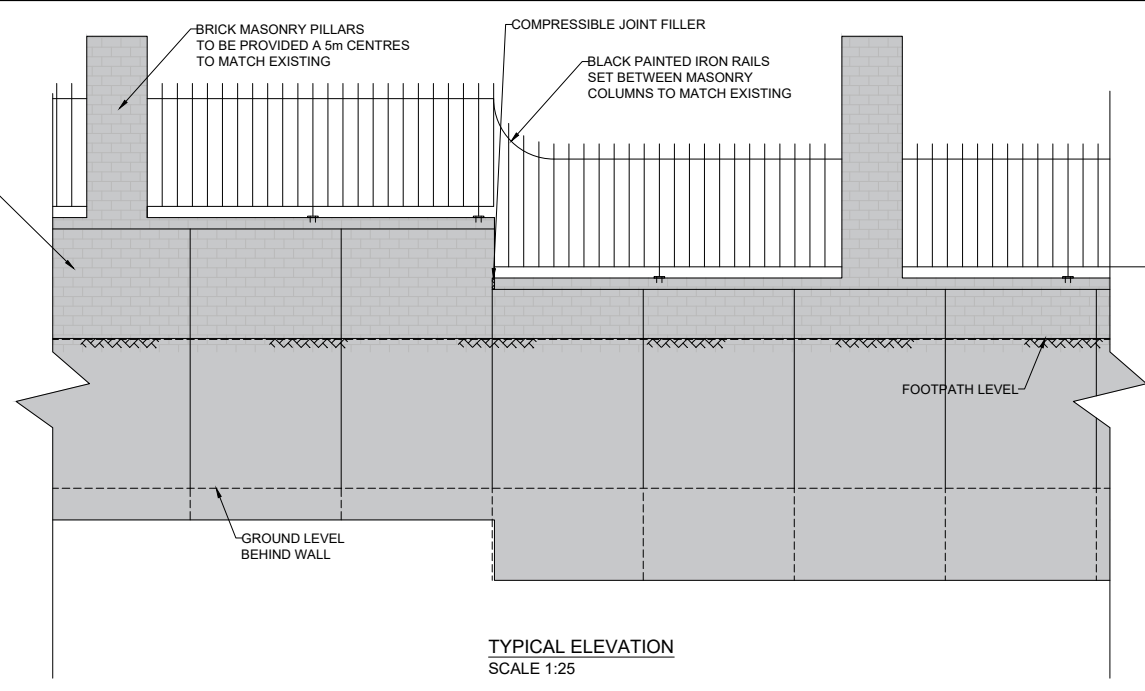
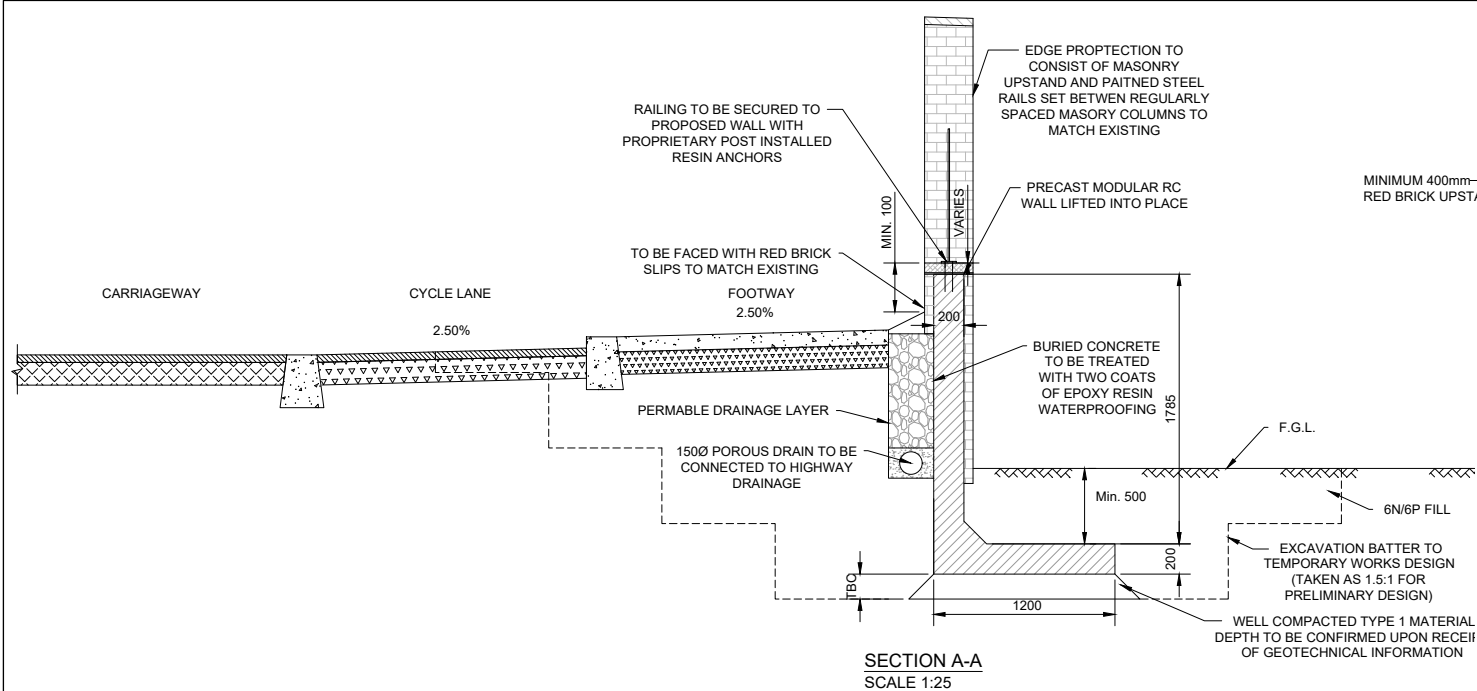

- NOTES:**
- ALL DIMENSIONS ARE SHOWN IN MILLIMETRES UNLESS NOTED OTHERWISE.
 - ALL LEVELS ARE SHOWN IN METRES ABOVE ORDINANCE OSi GEOID MODEL (OSGM15) MALIN HEAD.
 - FINISHES:
BURIED UNFORMED SURFACES -U1
BURIED FORMED SURFACES -F1
EXPOSED UNFORMED SURFACES (EXCLUDING AREA TO BE WATERPROOFED) -U3
ALL OTHER EXPOSED FORMED SURFACED -F4
 - MATERIALS:
LOCATION: CONCRETE GRADE: -C32/40 (50% GGBS)
RETAINING WALLS
NON-STRUCTURAL CONCRETE: CONCRETE GRADE: -S12
LOCATION: CONCRETE FOR BLINDING
 - BURIED CONCRETE SURFACES SHALL BE TREATED WITH TWO COATS OF EPOXY RESIN WATERPROOFING PAINT IN ACCORDANCE WITH TII CC-SPW-01700.
 - ALL EXPOSED CONCRETE SHALL BE IMPREGNATED WITH A HYDROPHOBIC PORE LINER IN ACCORDANCE WITH THE TII CC-SPW-01700.
 - EXTERNAL CONCRETE ARISING TO BE CHAMFERED 25x25 UNLESS NOTED OTHERWISE.
 - STONE MASONRY FACING TO BE ANCHORED TO RETAINING WALL USING ANCON POST FIXED STAFFIX UNIVERSAL WALL STARTER SYSTEM AND S021 125MM WALL TIES OR EQUIVALENT AT 600MM STAGGERED HORIZONTAL AND VERTICAL CENTRES.
 - LOCALISED SOFT SPOTS, IF PRESENT, TO BE EXCAVATED AND REPLACED WITH 6N/6P.

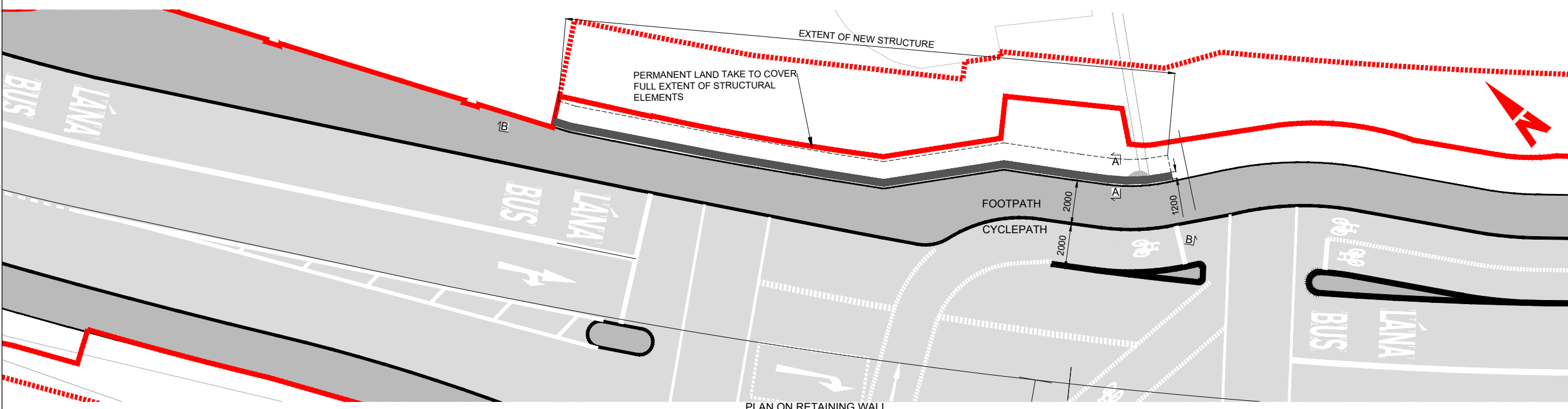
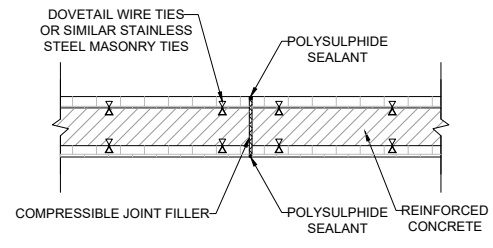
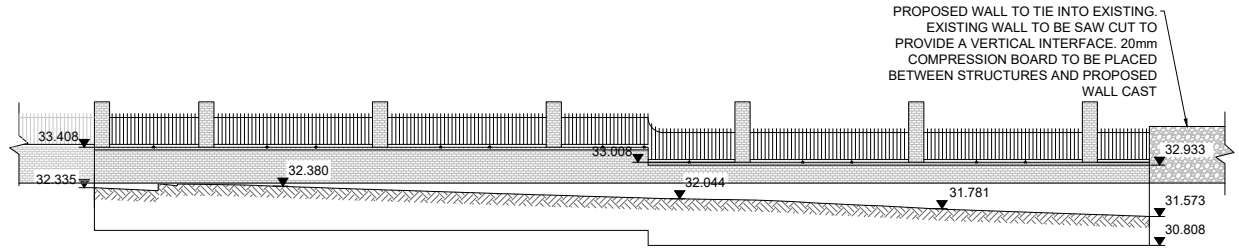

Disclaimer
 a. © National Transport Authority (NTA) 2022. This drawing is confidential and the copyright in it is owned by NTA. This drawing must not be either loaned, copied or otherwise reproduced in whole or in part or used for any purpose without the prior permission of NTA.
 b. This drawing is to be used for the design element identified in the titleblock. Other information shown is to be considered indicative only. The drawing is to be read in conjunction with all other relevant design drawings.
 c. O.S. data used for plans are printed under © Ordnance Survey Ireland Government of Ireland. All rights reserved. Licence Number 2022/OS_NMA_180 National Transport Authority. All elevations are in metres and relate to OSi Geoid Model (OSGM15) Malin Head. All Co-ordinates are in Irish Transverse Mercator Grid (ITM) as defined by OSi active local GPS station.
 d. Information concerning the position of apparatus shown on this drawing is based on drawings supplied by the utility owners and/or the utility works contractor, whilst every care has been taken in the preparation of this drawing, positions should be taken as approximate and are intended for general guidance only and no representation is made by the NTA as to the accuracy, completeness, sufficiency or otherwise of this drawing and the position of the apparatus. The information contained herein does not purport to be comprehensive or final as the apparatus is subject to being altered and/or superceded. Recipients should not rely on this information. Any liabilities are hereby expressly disclaimed.

The information contained herein has been provided by the NTA but does not purport to be comprehensive or final. Recipients should not rely on the information. Neither the NTA nor any of its directors, officers, employees, agents, stakeholders or advisers make any representation or warranty as to, or accept any liability or responsibility in relation to, the adequacy, accuracy, reasonableness or completeness of the information provided as part of this document or any matter on which the information is based (including but not limited to loss or damage arising as a result of reliance by recipients on the information or any part of it). Any liabilities are hereby expressly disclaimed.

Project Ireland 2040
 Building Ireland's Future

Rev	Date	Drn	Chk'd	App'd	Description
M01	27/01/2023	RG	JM	RS	ISSUE FOR PHASE 4: PLANNING

Client
 NTA
 Údarás Náisiúnta Iompair
 National Transport Authority

Engineering Designer
 Jacobs

Date: 27/01/2023
 Project Code: BCIDB
 Originator Code: JAC

Scales shown @ A1 as shown @ A3
 Drawn: RG
 Checked: JM
 Approved: RS

Programme Title
 BUSCONNECTS DUBLIN
 CORE BUS CORRIDORS INFRASTRUCTURE WORKS

Drawing Title
 BRAY TO CITY CENTRE SCHEME
 DUN LAOGHAIRE RATHDOWN COUNTY COUNCIL
 GENERAL ARRANGEMENT
 R13-RW024 RETAINING WALL

Drawing File Name: BCIDB-JAC-STR_GA-0013_RW_00-DR-CB-1102
 Sheet Number: 01 of 1
 Status: A
 Rev: M01

DO NOT SCALE USE FIGURED DIMENSIONS ONLY

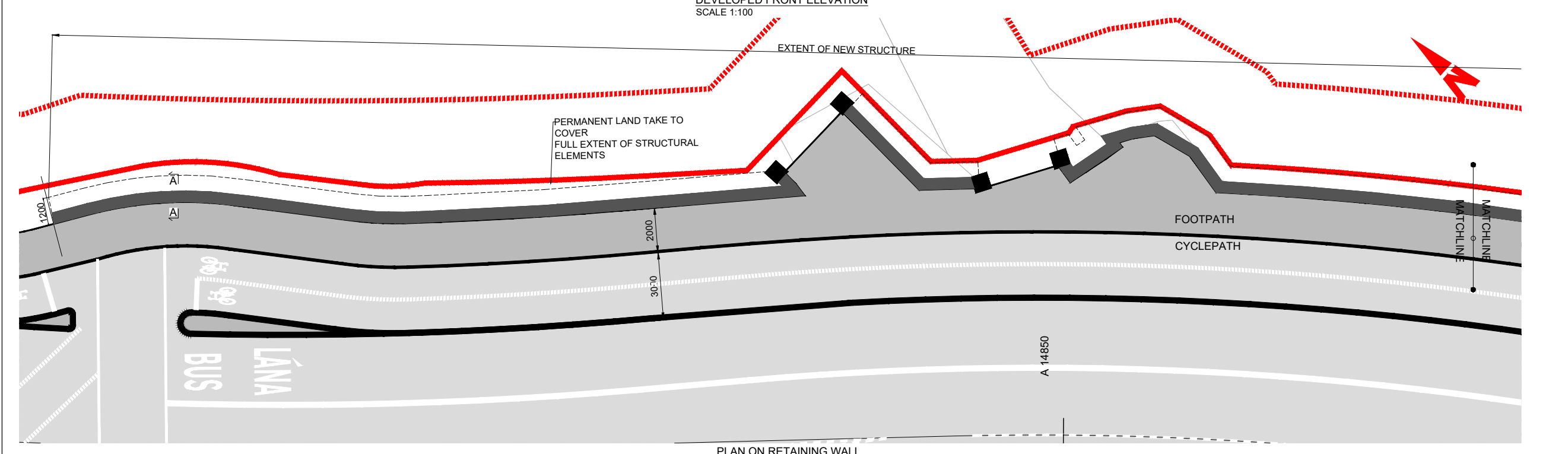
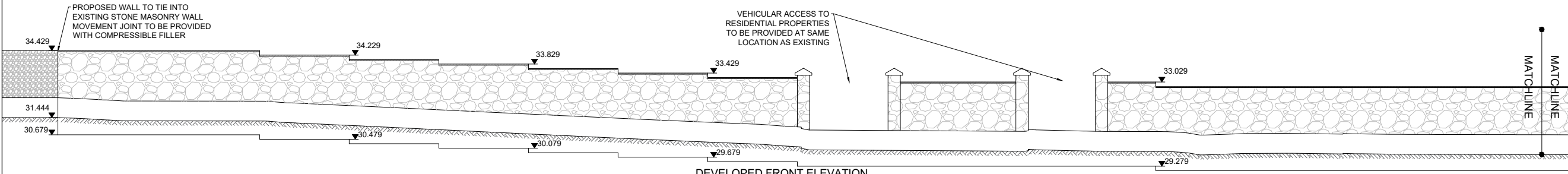
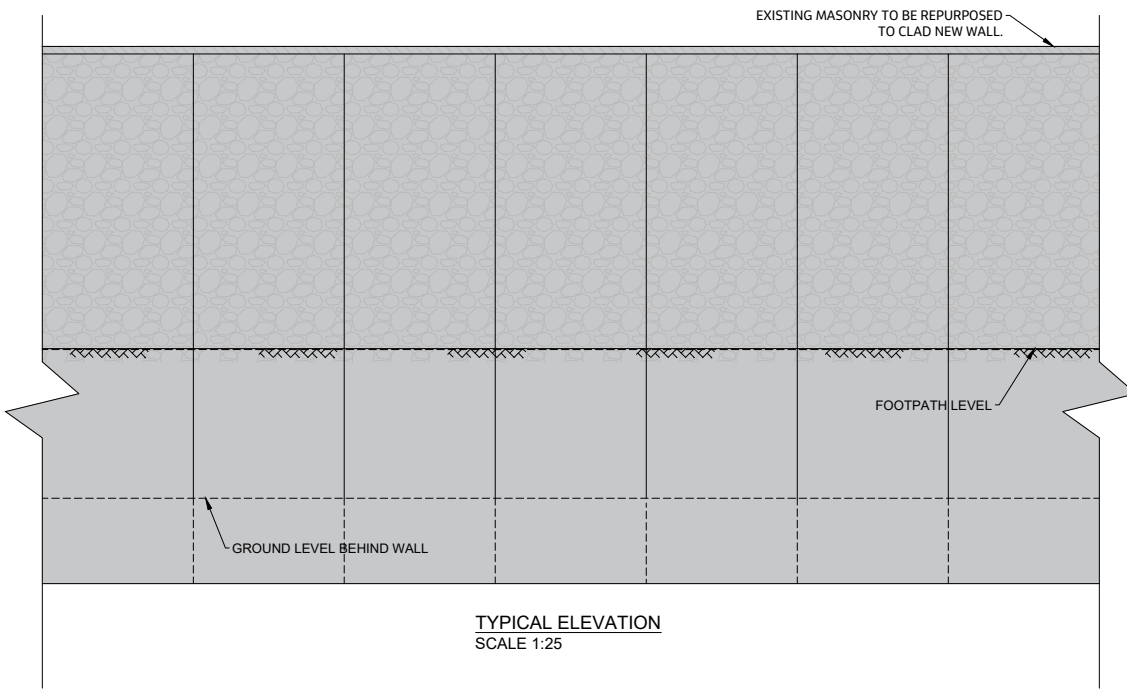
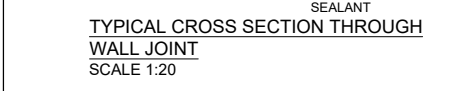
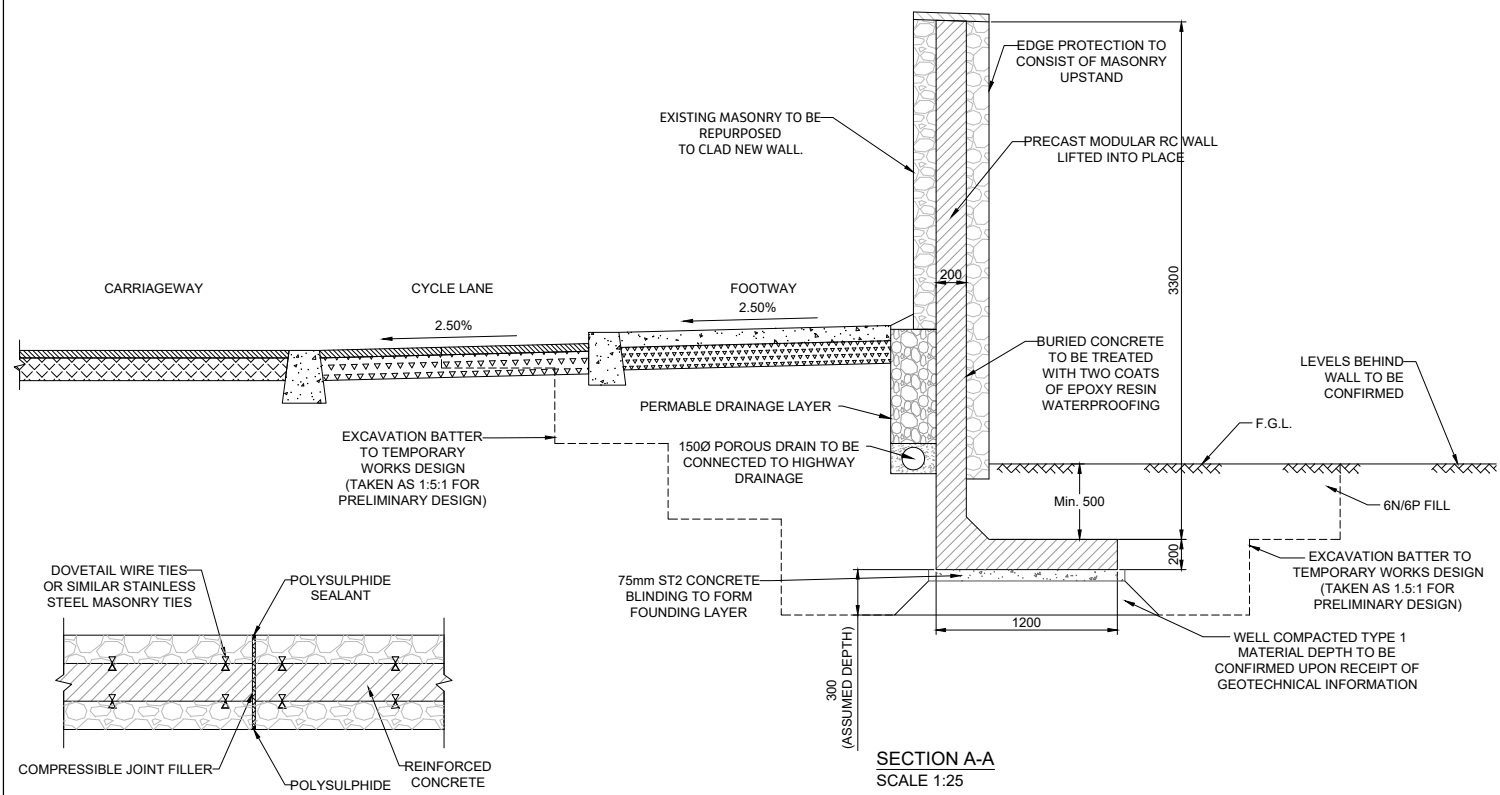

NOTES:

- ALL DIMENSIONS ARE SHOWN IN MILLIMETRES UNLESS NOTED OTHERWISE.
- ALL LEVELS ARE SHOWN IN METRES ABOVE ORDINANCE OSI GEOD MODEL (OSGM15) MALIN HEAD.
- FINISHES:
BURIED UNFORMED SURFACES -U1
BURIED FORMED SURFACES -F1
EXPOSED UNFORMED SURFACES (EXCLUDING AREA TO BE WATERPROOFED) -U3
ALL OTHER EXPOSED FORMED SURFACES -F4
- MATERIALS:
LOCATION: CONCRETE GRADE:
RETAINING WALLS -C32/40 (50% GGBS)
NON-STRUCTURAL CONCRETE: CONCRETE GRADE:
LOCATION: CONCRETE FOR BLINDING -ST2
- BURIED CONCRETE SURFACES SHALL BE TREATED WITH TWO COATS OF EPOXY RESIN WATERPROOFING PAINT IN ACCORDANCE WITH TII CC-SPW-01700.
- ALL EXPOSED CONCRETE SHALL BE IMPREGNATED WITH A HYDROPHOBIC PORE LINER IN ACCORDANCE WITH THE TII CC-SPW-01700.
- EXTERNAL CONCRETE EDGES TO BE CHAMFERED 25x25 UNLESS NOTED OTHERWISE.
- STONE MASONRY FACING TO BE ANCHORED TO RETAINING WALL USING ANCON POST FIXED STAFFIX UNIVERSAL WALL STARTER SYSTEM AND S021 125MM WALL TIES OR EQUIVALENT AT 600MM STAGGERED HORIZONTAL AND VERTICAL CENTRES.
- LOCALISED SOFT SPOTS, IF PRESENT, TO BE EXCAVATED AND REPLACED WITH 6N/6P.

Disclaimer
 a. © National Transport Authority (NTA) 2022. This drawing is confidential and the copyright in it is owned by NTA. This drawing must not be either loaned, copied or otherwise reproduced in whole or in part or used for any purpose without the prior permission of NTA.
 b. This drawing is to be used for the design element identified in the titleblock. Other information shown is to be considered indicative only. The drawing is to be read in conjunction with all other relevant design drawings.
 c. O.S. data used for plans are printed under © Ordnance Survey Ireland Government of Ireland. All rights reserved. Licence Number 2022/OS_NMA_180 National Transport Authority. All elevations are in metres and relate to OSI Geoid Model (OSGM15) Malin Head. All Co-ordinates are in Irish Transverse Mercator Grid (ITM) as defined by OSI active local GPS station.
 d. Information concerning the position of apparatus shown on this drawing is based on drawings supplied by the utility owners and/or the utility works contractor, whilst every care has been taken in the preparation of this drawing, positions should be taken as approximate and are intended for general guidance only and no representation is made by the NTA as to the accuracy, completeness, sufficiency or otherwise of this drawing and the position of the apparatus. The information contained herein does not purport to be comprehensive or final as the apparatus is subject to being altered and/or superceded. Recipients should not rely on this information. Any liabilities are hereby expressly disclaimed.

Project Ireland 2040
 Building Ireland's Future

Rev	Date	Drn	Chk'd	App'd	Description
M01	27/01/2023	RG	JM	RS	ISSUE FOR PHASE 4: PLANNING

Client: **NTA**
 Údarás Náisiúnta Iompair
 National Transport Authority

Engineering Designer: **Jacobs**

Date: 27/01/2023
 Project Code: BCIDB
 Originator Code: JAC

Drawn: RG
 Checked: JM
 Approved: RS

Programme Title: **BUSCONNECTS DUBLIN CORE BUS CORRIDORS INFRASTRUCTURE WORKS**

Drawing Title: BRAY TO CITY CENTRE SCHEME
 DUN LAOGHAIRE RATHDOWN COUNTY COUNCIL
 GENERAL ARRANGEMENT
 R13-RW036 RETAINING WALL

Drawing File Name: BCIDB-JAC-STR_GA-0013_RW_00-DR-CB-1103
 Sheet Number: 01 of 1
 Status: A
 Rev: M01

DO NOT SCALE USE FIGURED DIMENSIONS ONLY

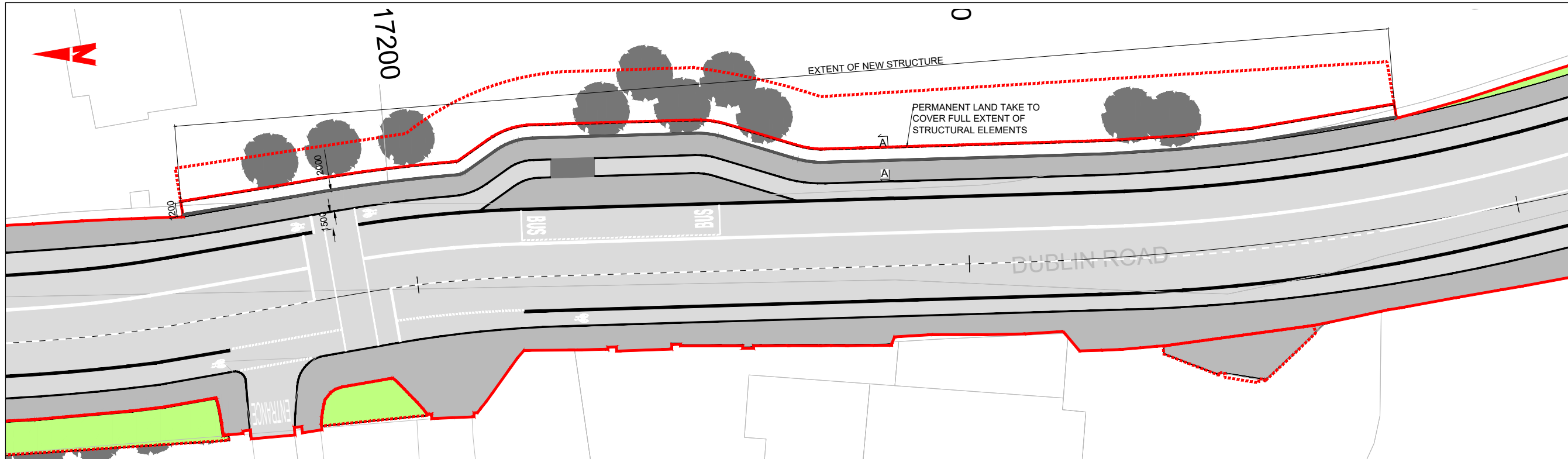

- NOTES:**
- ALL DIMENSIONS ARE SHOWN IN MILLIMETRES UNLESS NOTED OTHERWISE.
 - ALL LEVELS ARE SHOWN IN METRES ABOVE ORDINANCE OSI GEOD MODEL (OSGM15) MALIN HEAD.
 - FINISHES:
BURIED UNFORMED SURFACES -U1
BURIED FORMED SURFACES -F1
EXPOSED UNFORMED SURFACES (EXCLUDING AREA TO BE WATERPROOFED) -U3
ALL OTHER EXPOSED FORMED SURFACED -F4
 - MATERIALS:
LOCATION: CONCRETE GRADE: -C32/40 (50% GGBS)
RETAINING WALLS
NON-STRUCTURAL CONCRETE: CONCRETE GRADE: -ST2
LOCATION: CONCRETE FOR BLINDING
 - BURIED CONCRETE SURFACES SHALL BE TREATED WITH TWO COATS OF EPOXY RESIN WATERPROOFING PAINT IN ACCORDANCE WITH TII CC-SPW-01700.
 - ALL EXPOSED CONCRETE SHALL BE IMPREGNATED WITH A HYDROPHOBIC PORE LINER IN ACCORDANCE WITH THE TII CC-SPW-01700.
 - EXTERNAL CONCRETE ARISES TO BE CHAMFERED 25x25 UNLESS NOTED OTHERWISE.
 - STONE MASONRY FACING TO BE ANCHORED TO RETAINING WALL USING ANCON POST FIXED STAFFIX UNIVERSAL WALL STARTER SYSTEM AND S021 125MM WALL TIES OR EQUIVALENT AT 600MM STAGGERED HORIZONTAL AND VERTICAL CENTRES.
 - LOCALISED SOFT SPOTS, IF PRESENT, TO BE EXCAVATED AND REPLACED WITH 6N/6P.

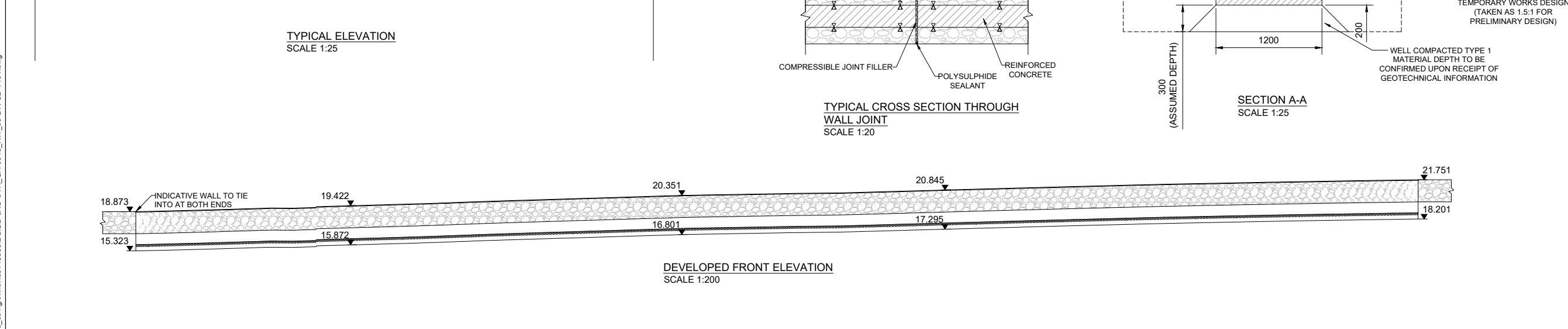
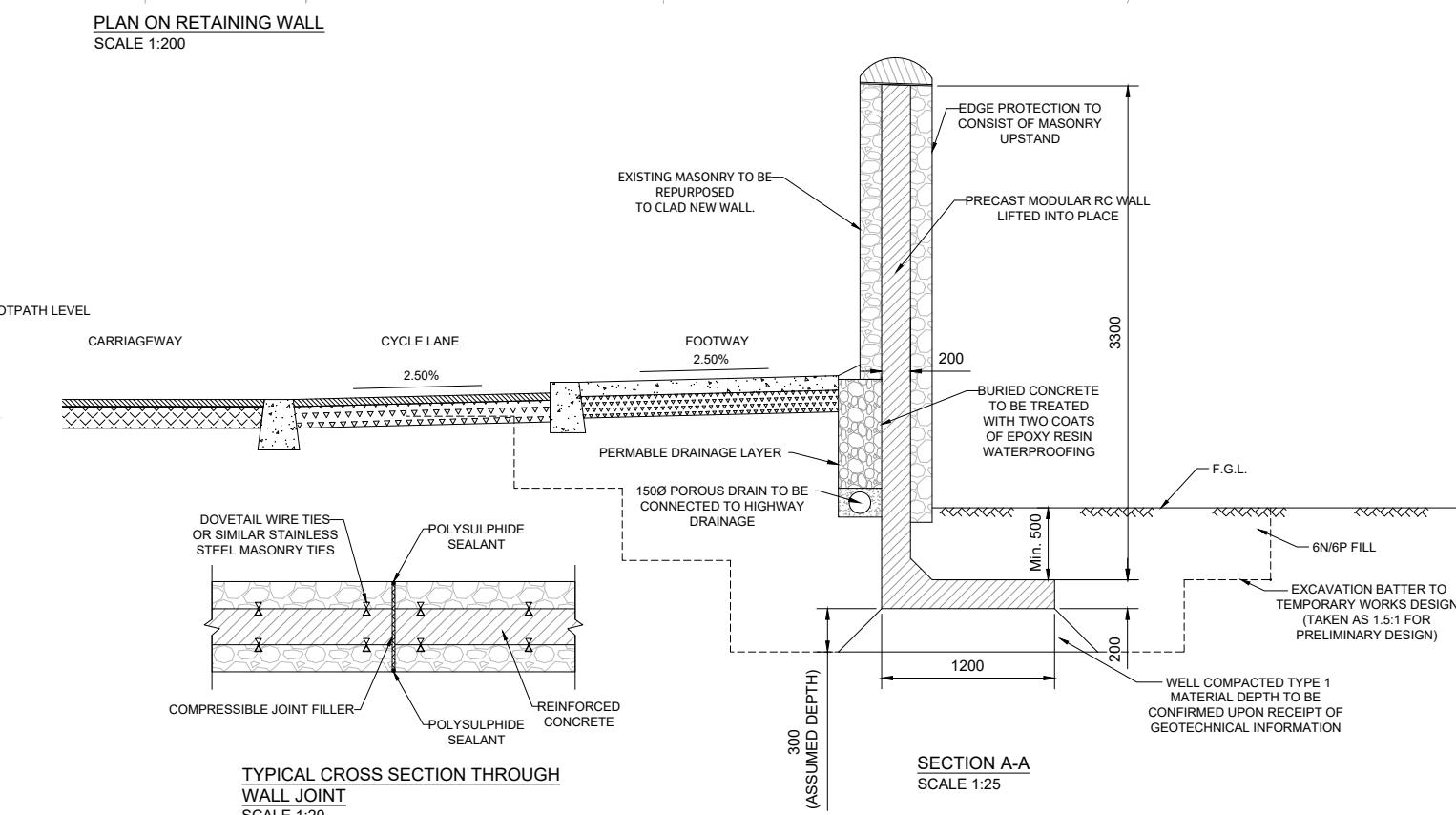
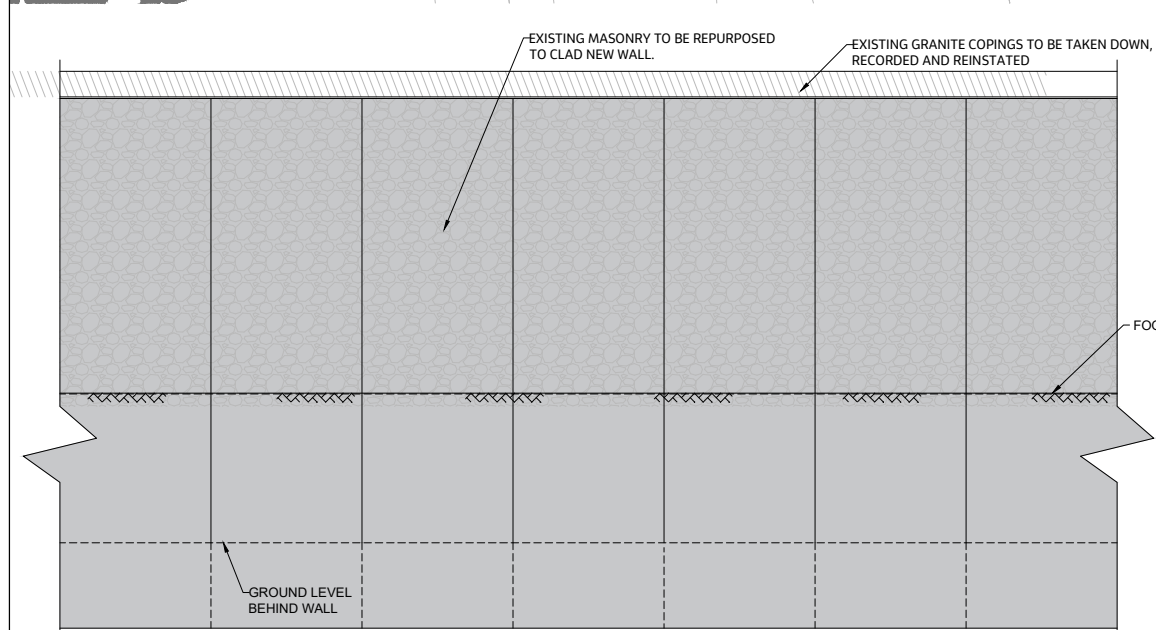

C:\pwork\king\jacobs_uk_highways_ssa4\glennor\0148698\BCIDB-JAC-STR_GA-0013_RW_00-DR-CB-1104.dwg

Disclaimer:

a. © National Transport Authority (NTA) 2022. This drawing is confidential and the copyright in it is owned by NTA. This drawing must not be either loaned, copied or otherwise reproduced in whole or in part or used for any purpose without the prior permission of NTA.

b. This drawing is to be used for the design element identified in the titleblock. Other information shown is to be considered indicative only. The drawing is to be read in conjunction with all other relevant design drawings.

c. O.S. data used for plans are printed under © Ordnance Survey Ireland Government of Ireland. All rights reserved. Licence Number 2022/OS_NMA_180 National Transport Authority. All elevations are in metres and relate to OSI Geoid Model (OSGM15) Malin Head. All Co-ordinates are in Irish Transverse Mercator Grid (ITM) as defined by OSI active local GPS station.

d. Information concerning the position of apparatus shown on this drawing is based on drawings supplied by the utility owners and/or the utility works contractor, whilst every care has been taken in the preparation of this drawing, positions should be taken as approximate and are intended for general guidance only and no representation is made by the NTA as to the accuracy, completeness, sufficiency or otherwise of this drawing and the position of the apparatus. The information contained herein does not purport to be comprehensive or final as the apparatus is subject to being altered and/or superceded. Recipients should not rely on this information. Any liabilities are hereby expressly disclaimed.

e. The information contained herein has been provided by the NTA but does not purport to be comprehensive or final. Recipients should not rely on the information. Neither the NTA nor any of its directors, officers, employees, agents, stakeholders or advisers make any representation or warranty as to, or accept any liability or responsibility in relation to, the adequacy, accuracy, reasonableness or completeness of the information provided as part of this document or any matter on which the information is based (including but not limited to loss or damage arising as a result of reliance by recipients on the information or any part of it). Any liabilities are hereby expressly disclaimed.

Rev	Date	Drn	Chk'd	App'd	Description
M01	27/01/2023	RG	JM	RS	ISSUE FOR PHASE 4: PLANNING

Client: **NTA**
Údarás Náisiúnta Iompair
National Transport Authority

Engineering Designer: **Jacobs**

Date: 27/01/2023
Project Code: BCIDB
Originator Code: JAC

Scales shown @ A1 as shown @ A3
Drawn: RG
Checked: JM
Approved: RS

Programme Title: **BUSCONNECTS DUBLIN CORE BUS CORRIDORS INFRASTRUCTURE WORKS**

Drawing Title: BRAY TO CITY CENTRE SCHEME
DUN LAOGHAIRE RATHDOWN COUNTY COUNCIL
GENERAL ARRANGEMENT
R13-RW013 RETAINING WALL

Drawing File Name: BCIDB-JAC-STR_GA-0013_RW_00-DR-CB-1104
Sheet Number: 01 of 1
Status: A
Rev: M01

DO NOT SCALE USE FIGURED DIMENSIONS ONLY

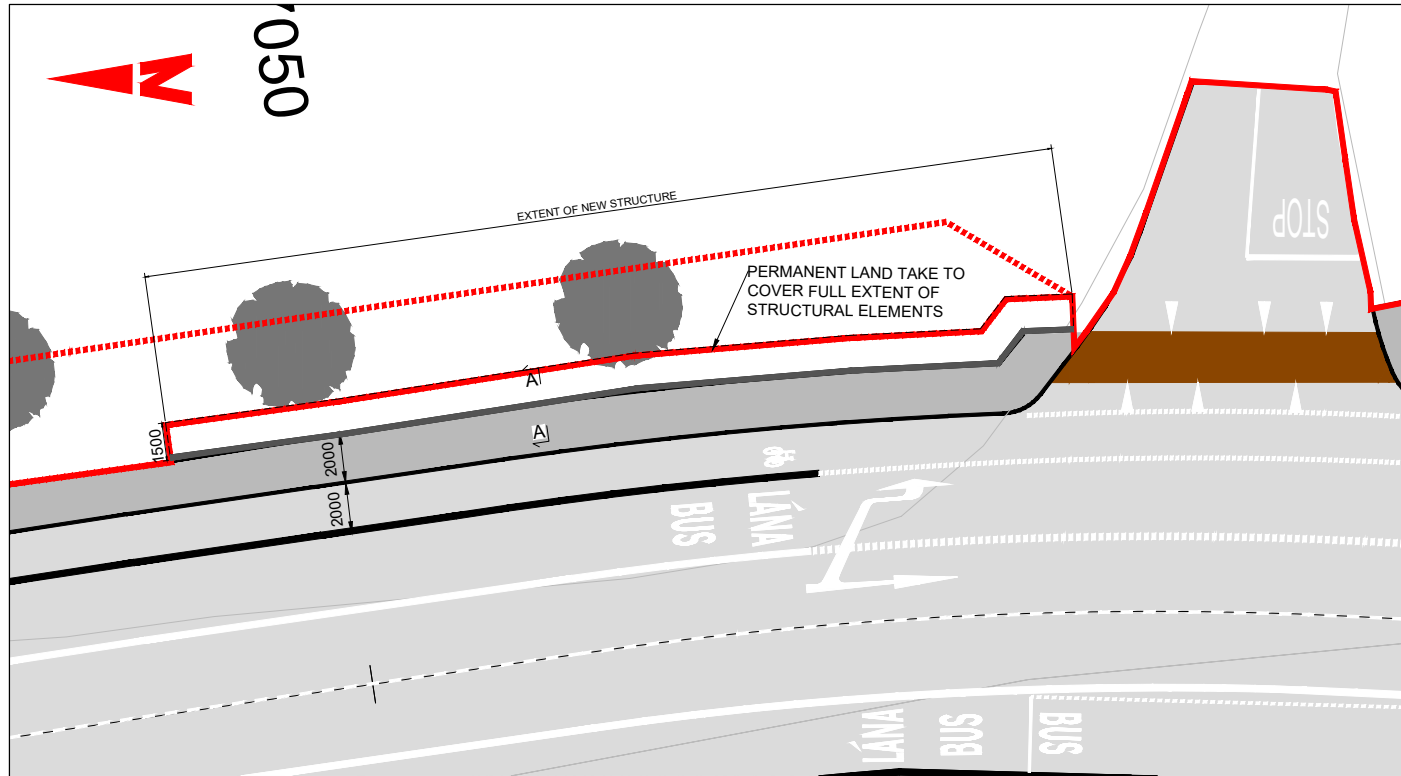

PLAN ON RETAINING WALL
SCALE 1:150

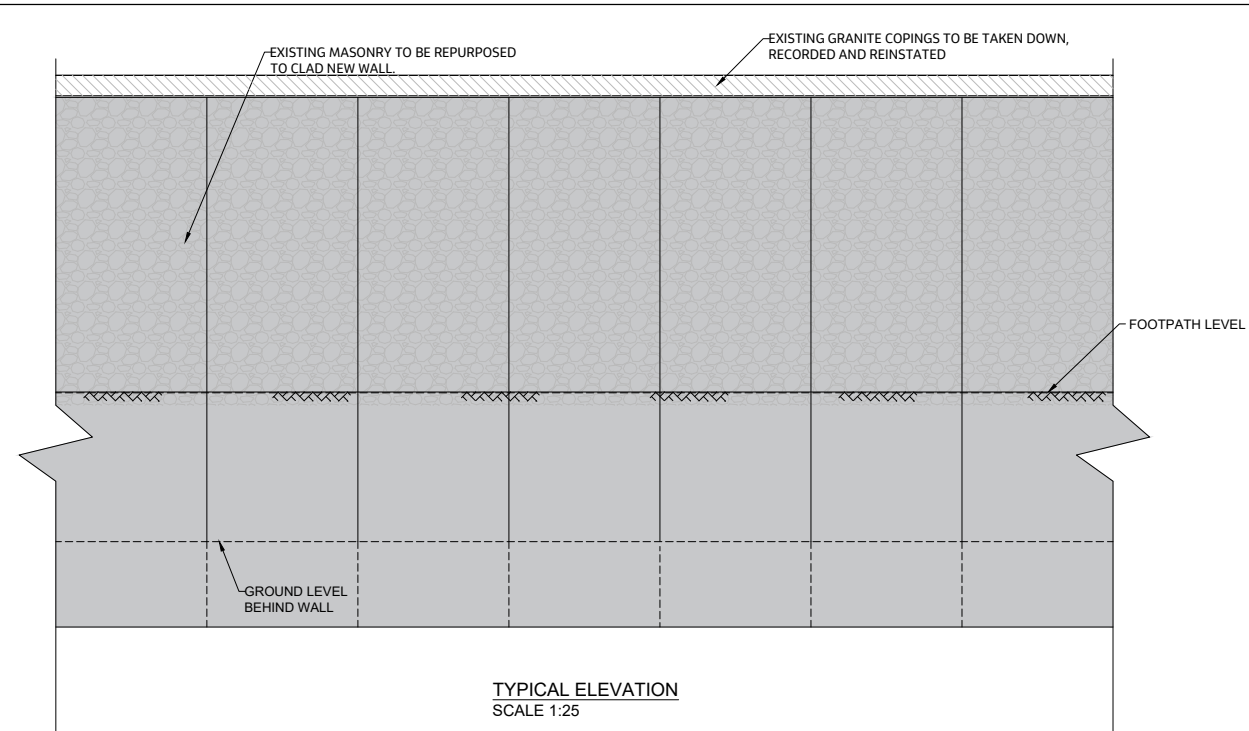

TYPICAL ELEVATION
SCALE 1:25

- NOTES:**
- ALL DIMENSIONS ARE SHOWN IN MILLIMETRES UNLESS NOTED OTHERWISE.
 - ALL LEVELS ARE SHOWN IN METRES ABOVE ORDINANCE OSI GEOID MODEL (OSGM15) MALIN HEAD.
 - FINISHES:
BURIED UNFORMED SURFACES -U1
BURIED FORMED SURFACES -F1
EXPOSED UNFORMED SURFACES (EXCLUDING AREA TO BE WATERPROOFED) -U3
ALL OTHER EXPOSED FORMED SURFACES -F4
 - MATERIALS:
LOCATION: RETAINING WALLS CONCRETE GRADE: -C32/40 (50% GGBS)
NON-STRUCTURAL CONCRETE: LOCATION: CONCRETE FOR BLINDING CONCRETE GRADE: -ST2
 - BURIED CONCRETE SURFACES SHALL BE TREATED WITH TWO COATS OF EPOXY RESIN WATERPROOFING PAINT IN ACCORDANCE WITH TII CC-SPW-01700.
 - ALL EXPOSED CONCRETE SHALL BE IMPREGNATED WITH A HYDROPHOBIC PORE LINER IN ACCORDANCE WITH THE TII CC-SPW-01700.
 - EXTERNAL CONCRETE EDGES ARE TO BE CHAMFERED 25x25 UNLESS NOTED OTHERWISE.
 - STONE MASONRY FACING TO BE ANCHORED TO RETAINING WALL USING ANCON POST FIXED STAFFIX UNIVERSAL WALL STARTER SYSTEM AND S021 125MM WALL TIES OR EQUIVALENT AT 600MM STAGGERED HORIZONTAL AND VERTICAL CENTRES.
 - LOCALISED SOFT SPOTS, IF PRESENT, TO BE EXCAVATED AND REPLACED WITH 6N/6P.

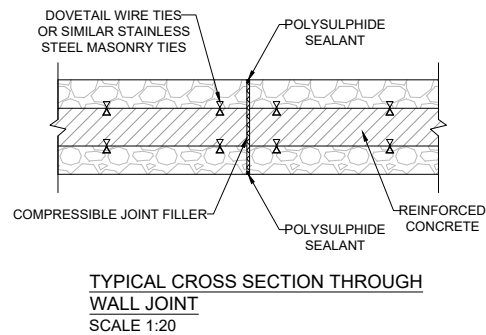

TYPICAL CROSS SECTION THROUGH
WALL JOINT
SCALE 1:20

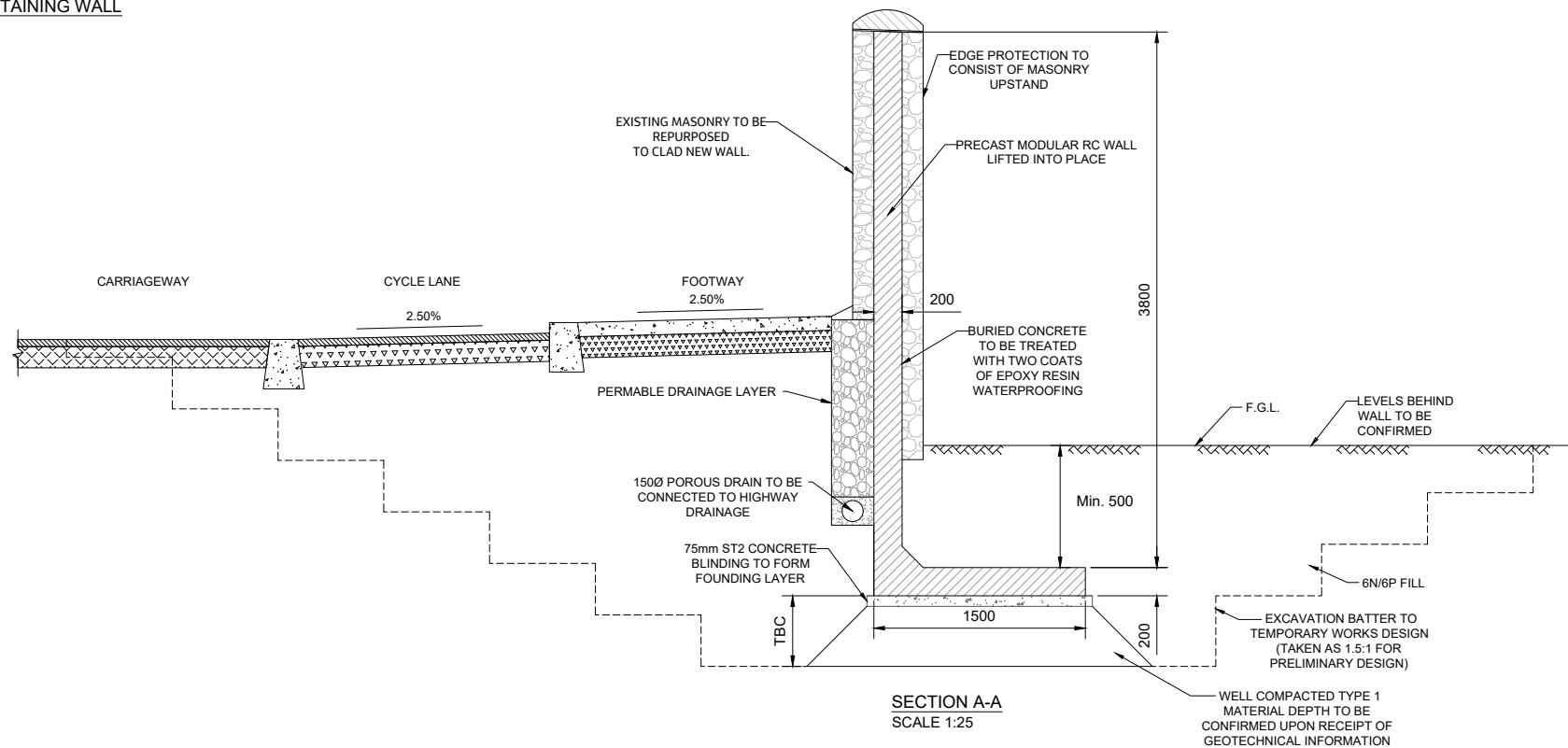

SECTION A-A
SCALE 1:25

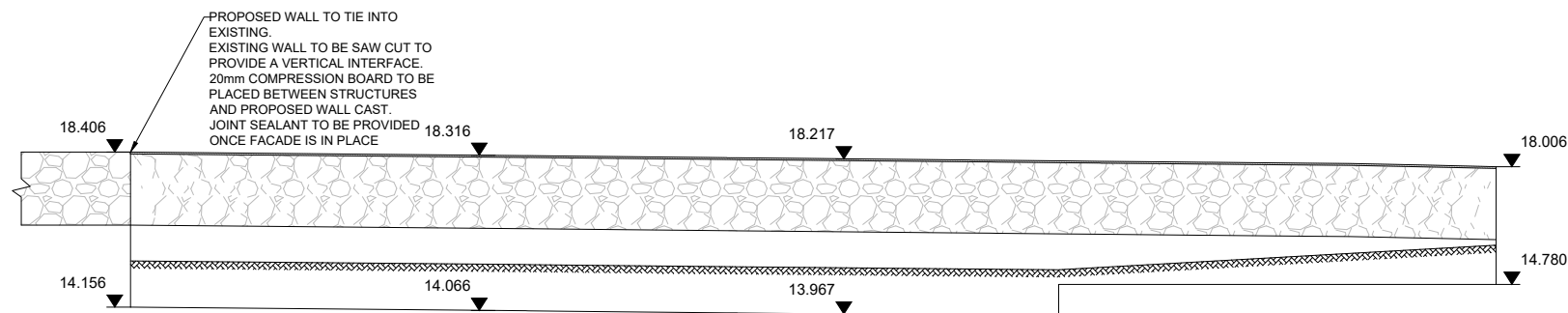

DEVELOPED FRONT ELEVATION
SCALE 1:100

C:\pwworking\jacobs_uk_highways_ss4\glennor\0148698\BCIDB-JAC-STR_GA-0013_RW_00-DR-CB-1105.dwg

Disclaimer

a. © National Transport Authority (NTA) 2022. This drawing is confidential and the copyright in it is owned by NTA. This drawing must not be either loaned, copied or otherwise reproduced in whole or in part or used for any purpose without the prior permission of NTA.

b. This drawing is to be used for the design element identified in the titleblock. Other information shown is to be considered indicative only. The drawing is to be read in conjunction with all other relevant design drawings.

c. O.S. data used for plans are printed under © Ordnance Survey Ireland Government of Ireland. All rights reserved. Licence Number 2022/OS_NMA_180 National Transport Authority. All elevations are in metres and relate to OSI Geoid Model (OSGM15) Malin Head. All Co-ordinates are in Irish Transverse Mercator Grid (ITM) as defined by OSI active local GPS station.

d. Information concerning the position of apparatus shown on this drawing is based on drawings supplied by the utility owners and/or the utility works contractor, whilst every care has been taken in the preparation of this drawing, positions should be taken as approximate and are intended for general guidance only and no representation is made by the NTA as to the accuracy, completeness, sufficiency or otherwise of this drawing and the position of the apparatus. The information contained herein does not purport to be comprehensive or final as the apparatus is subject to being altered and/or superceded. Recipients should not rely on this information. Any liabilities are hereby expressly disclaimed.

e. The information contained herein has been provided by the NTA but does not purport to be comprehensive or final. Recipients should not rely on the information. Neither the NTA nor any of its directors, officers, employees, agents, stakeholders or advisers make any representation or warranty as to, or accept any liability or responsibility in relation to, the adequacy, accuracy, reasonableness or completeness of the information provided as part of this document or any matter on which the information is based (including but not limited to loss or damage arising as a result of reliance by recipients on the information or any part of it). Any liabilities are hereby expressly disclaimed.

Rev	Date	Drn	Chk'd	App'd	Description
M01	27/01/2023	RG	JM	RS	ISSUE FOR PHASE 4: PLANNING

Date	27/01/2023	Scales shown @ A1 as shown @ A3	Drawn	RG
Project Code	BCIDB	Originator Code	JAC	Checked
			JM	Approved
			RS	

Programme Title BUSCONNECTS DUBLIN CORE BUS CORRIDORS INFRASTRUCTURE WORKS			
Drawing Title BRAY TO CITY CENTRE SCHEME DUN LAOGHAIRE RATHDOWN COUNTY COUNCIL GENERAL ARRANGEMENT R13-RW038 RETAINING WALL			
Drawing File Name	BCIDB-JAC-STR_GA-0013_RW_00-DR-CB-1105	Sheet Number	01 of 1
Status	A	Rev	M01

DO NOT SCALE USE FIGURED DIMENSIONS ONLY

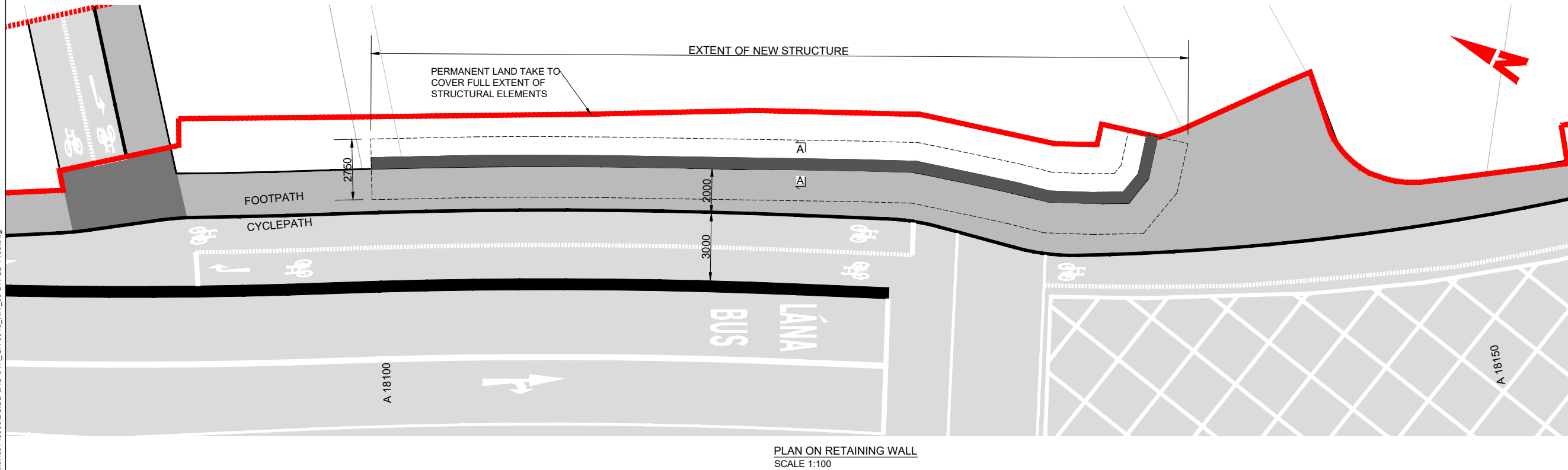
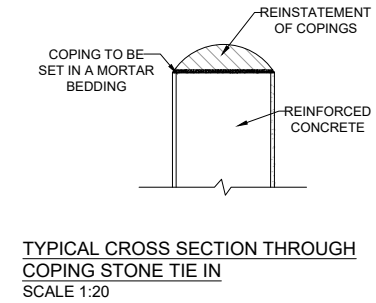
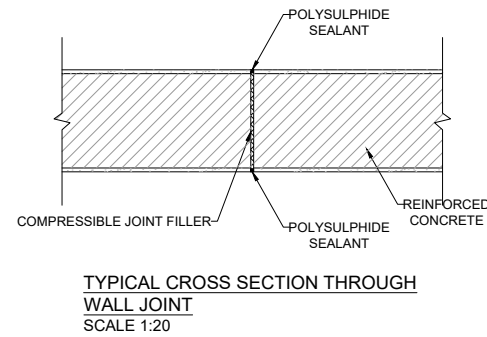
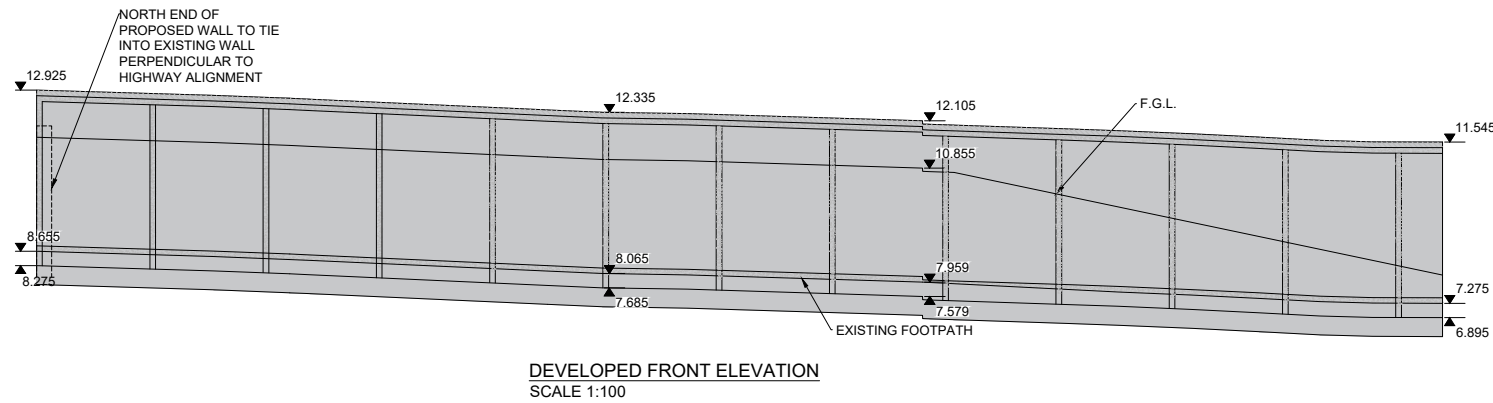
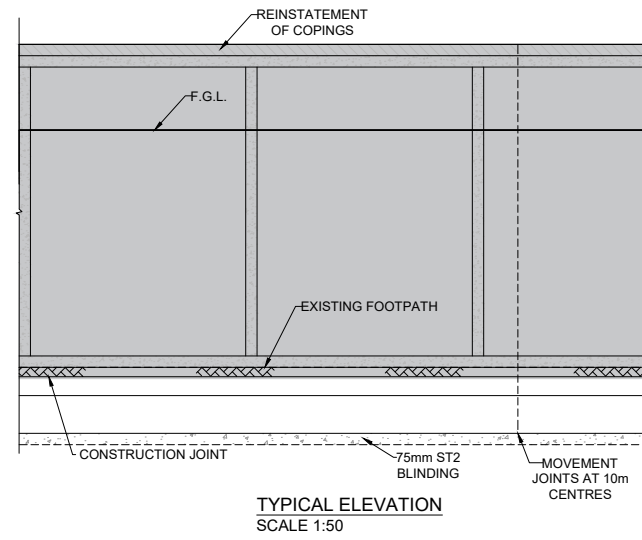
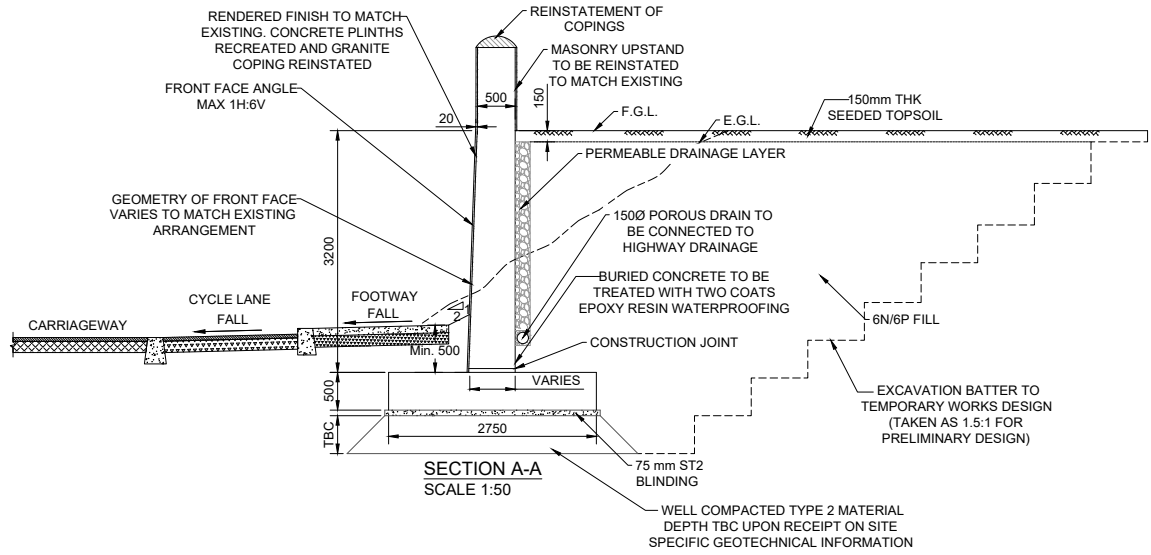

- NOTES:**
- ALL DIMENSIONS ARE SHOWN IN MILLIMETRES UNLESS NOTED OTHERWISE.
 - ALL LEVELS ARE SHOWN IN METRES ABOVE ORDINANCE OSI GEOD MODEL (OSGM15) MALIN HEAD.
 - FINISHES:
 - BURIED UNFORMED SURFACES -U1
 - BURIED UNFORMED SURFACES -F1
 - EXPOSED UNFORMED SURFACES (EXCLUDING AREA TO BE WATERPROOFED) -U3
 - ALL OTHER EXPOSED FORMED SURFACED -F4
 - MATERIALS:
 - LOCATION: CONCRETE GRADE: RETAINING WALLS -C32/40 (50% GGBS)
 - NON-STRUCTURAL CONCRETE: CONCRETE GRADE: CONCRETE FOR BLINDING -ST2
 - BURIED CONCRETE SURFACES SHALL BE TREATED WITH TWO COATS OF EPOXY RESIN WATERPROOFING PAINT IN ACCORDANCE WITH TI CC-SPW-01700.
 - ALL EXPOSED CONCRETE SHALL BE IMPREGNATED WITH A HYDROPHOBIC PORE LINER IN ACCORDANCE WITH THE TI CC-SPW-01700.
 - EXTERNAL CONCRETE ARISES TO BE CHAMFERED 25x25 UNLESS NOTED OTHERWISE.
 - STONE MASONRY FACING TO BE ANCHORED TO RETAINING WALL USING ANCON POST FIXED STAFFIX UNIVERSAL WALL STARTER SYSTEM AND S021 125MM WALL TIES OR EQUIVALENT AT 600MM STAGGERED HORIZONTAL AND VERTICAL CENTRES.
 - LOCALISED SOFT SPOTS, IF PRESENT, TO BE EXCAVATED AND REPLACED WITH 6N/6P.
 - NOMINAL MOVEMENT JOINTS TO BE AT 10M SPACING.

C:\pwworking\jacobs_uk_highways_ssa4\glennor\0148698\BCIDB-JAC-STR_GA-0013_RW_00-DR-CB-1108.dwg

Disclaimer

a. © National Transport Authority (NTA) 2022. This drawing is confidential and the copyright in it is owned by NTA. This drawing must not be either loaned, copied or otherwise reproduced in whole or in part or used for any purpose without the prior permission of NTA.

b. This drawing is to be used for the design element identified in the titleblock. Other information shown is to be considered indicative only. The drawing is to be read in conjunction with all other relevant design drawings.

c. O.S. data used for plans are printed under © Ordnance Survey Ireland Government of Ireland. All rights reserved. Licence Number 2022/O.S. NMA, 180 National Transport Authority. All elevations are in metres and relate to OSI Geoid Model (OSGM15) Malin Head. All Co-ordinates are in Irish Transverse Mercator Grid (ITM) as defined by OSI active local GPS station.

d. Information concerning the position of apparatus shown on this drawing is based on drawings supplied by the utility owners and/or the utility works contractor, whilst every care has been taken in the preparation of this drawing, positions should be taken as approximate and are intended for general guidance only and no representation is made by the NTA as to the accuracy, completeness, sufficiency or otherwise of this drawing and the position of the apparatus. The information contained herein does not purport to be comprehensive or final as the apparatus is subject to being altered and/or superseded. Recipients should not rely on this information. Any liabilities are hereby expressly disclaimed.

e. The information contained herein has been provided by the NTA but does not purport to be comprehensive or final. Recipients should not rely on the information. Neither the NTA nor any of its directors, officers, employees, agents, stakeholders or advisers make any representation or warranty as to, or accept any liability or responsibility in relation to, the adequacy, accuracy, reasonableness or completeness of the information provided as part of this document or any matter on which the information is based (including but not limited to loss or damage arising as a result of reliance by recipients on the information or any part of it). Any liabilities are hereby expressly disclaimed.

Rev	Date	Drn	Chk'd	App'd	Description
M01	27/01/2023	RG	JM	RS	ISSUE FOR PHASE 4: PLANNING

Client: **NTA**
Údarás Náisiúnta Iompair
National Transport Authority

Engineering Designer: **Jacobs**

Date: 27/01/2023
Project Code: BCIDB
Originator Code: JAC

Scales shown @ A1 as shown @ A3
Drawn: RG
Checked: JM
Approved: RS

Programme Title: **BUSCONNECTS DUBLIN CORE BUS CORRIDORS INFRASTRUCTURE WORKS**

Drawing Title: **BRAY TO CITY CENTRE SCHEME WICKLOW COUNTY COUNCIL GENERAL ARRANGEMENT R13-RW016 RETAINING WALL**

Drawing File Name: BCIDB-JAC-STR_GA-0013_RW_00-DR-CB-1108
Sheet Number: 01 of 1
Status: A
Rev: M01

DO NOT SCALE USE FIGURED DIMENSIONS ONLY

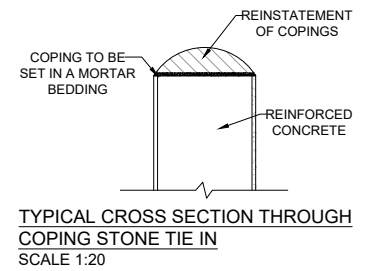
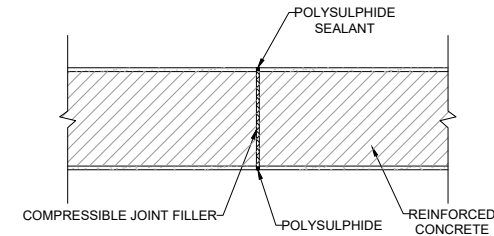
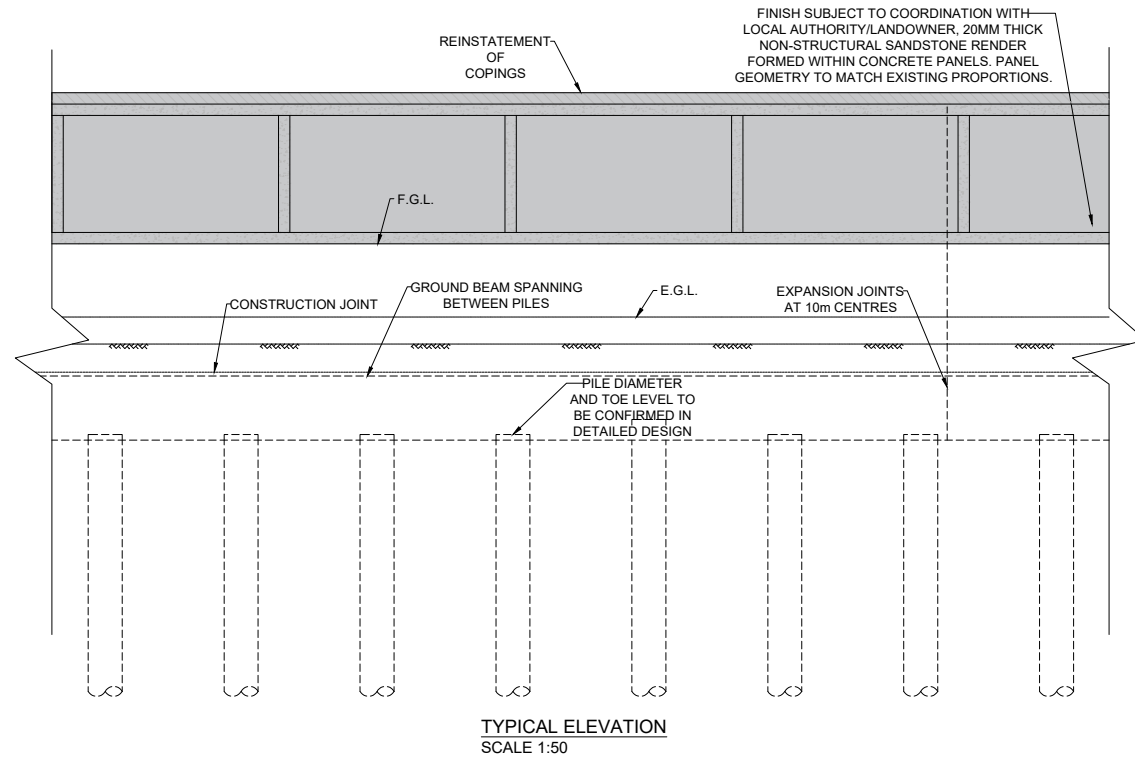
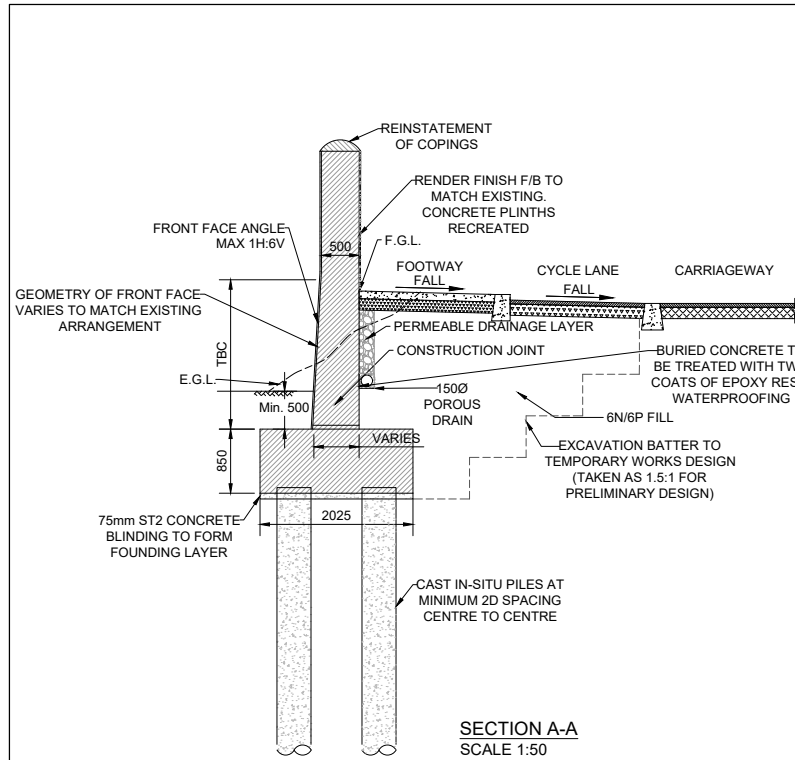

- NOTES:**
- ALL DIMENSIONS ARE SHOWN IN MILLIMETRES UNLESS NOTED OTHERWISE.
 - ALL LEVELS ARE SHOWN IN METRES ABOVE ORDINANCE OS/ GEOD MODEL (OSGM15) MALIN HEAD.
 - FINISHES:
BURIED UNFORMED SURFACES -U1
BURIED FORMED SURFACES -F1
EXPOSED UNFORMED SURFACES (EXCLUDING AREA TO BE WATERPROOFED) -U3
ALL OTHER EXPOSED FORMED SURFACES -F4
 - MATERIALS:
LOCATION: RETAINING WALLS CONCRETE GRADE: -C32/40 (50% GGBS)
NON-STRUCTURAL CONCRETE: LOCATION: CONCRETE FOR BLINDING CONCRETE GRADE: -S12
 - BURIED CONCRETE SURFACES SHALL BE TREATED WITH TWO COATS OF EPOXY RESIN WATERPROOFING PAINT IN ACCORDANCE WITH T11 CC-SPW-01700.
 - ALL EXPOSED CONCRETE SHALL BE IMPREGNATED WITH A HYDROPHOBIC PORE LINER IN ACCORDANCE WITH THE T11 CC-SPW-01700.
 - EXTERNAL CONCRETE ARISING TO BE CHAMFERED 25x25 UNLESS NOTED OTHERWISE.
 - STONE MASONRY FACING TO BE ANCHORED TO RETAINING WALL USING ANCON POST FIXED STAFFIX UNIVERSAL WALL STARTER SYSTEM AND S021 125MM WALL TIES OR EQUIVALENT AT 600MM STAGGERED HORIZONTAL AND VERTICAL CENTRES.
 - LOCALISED SOFT SPOTS, IF PRESENT, TO BE EXCAVATED AND REPLACED WITH 6N/6P.
 - NOMINAL MOVEMENT JOINTS TO BE AT 10M SPACING.

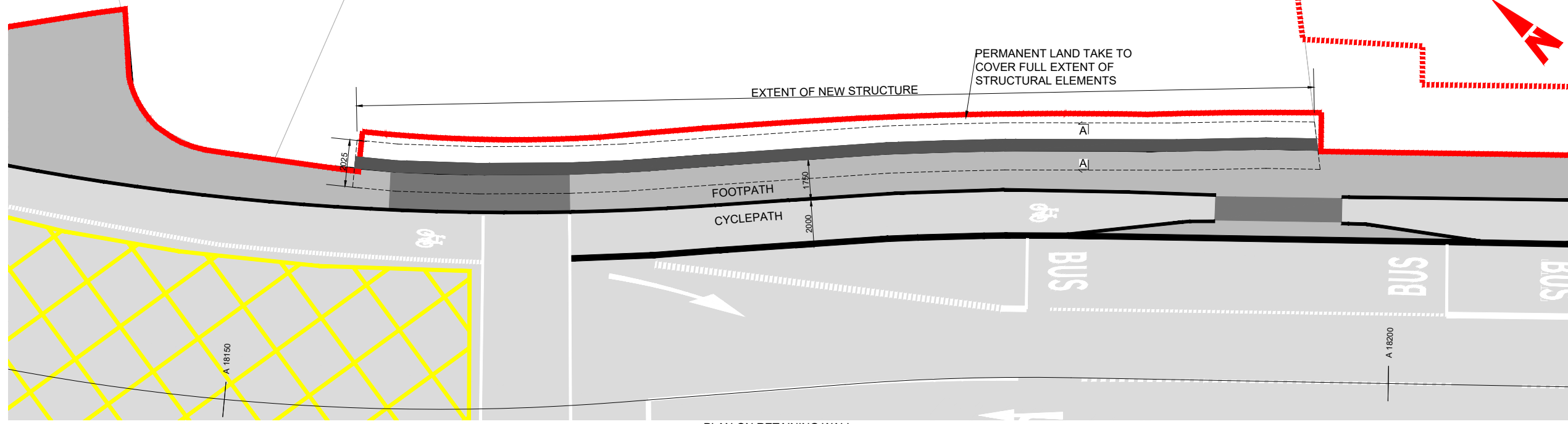
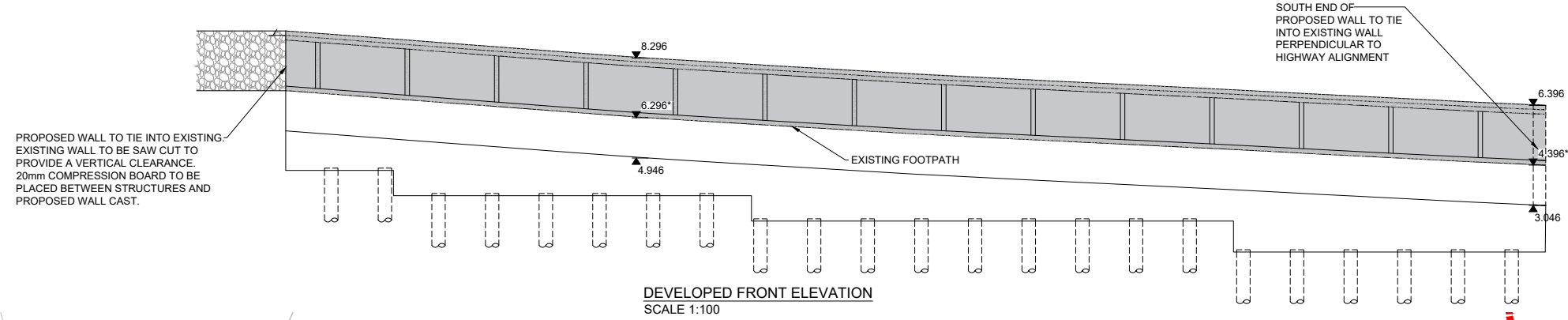

C:\pwworking\jacobs_uk_highways_ssa4\glennor\d0148698\BCIDB-JAC-STR_GA-0013_RW_00-DR-CB-1109.dwg

Disclaimer

a. © National Transport Authority (NTA) 2022. This drawing is confidential and the copyright in it is owned by NTA. This drawing must not be either loaned, copied or otherwise reproduced in whole or in part or used for any purpose without the prior permission of NTA.

b. This drawing is to be used for the design element identified in the titleblock. Other information shown is to be considered indicative only. The drawing is to be read in conjunction with all other relevant design drawings.

c. O.S. data used for plans are printed under © Ordnance Survey Ireland Government of Ireland. All rights reserved. Licence Number 2022/OS_NMA_180 National Transport Authority. All elevations are in metres and relate to OS/ Geoid Model (OSGM15) Malin Head. All Co-ordinates are in Irish Transverse Mercator Grid (ITM) as defined by OSI active local GPS station.

d. Information concerning the position of apparatus shown on this drawing is based on drawings supplied by the utility owners and/or the utility works contractor, whilst every care has been taken in the preparation of this drawing, positions should be taken as approximate and are intended for general guidance only and no representation is made by the NTA as to the accuracy, completeness, sufficiency or otherwise of this drawing and the position of the apparatus. The information contained herein does not purport to be comprehensive or final as the apparatus is subject to being altered and/or superseded. Recipients should not rely on this information. Any liabilities are hereby expressly disclaimed.

e. The information contained herein has been provided by the NTA but does not purport to be comprehensive or final. Recipients should not rely on the information. Neither the NTA nor any of its directors, officers, employees, agents, stakeholders or advisers make any representation or warranty as to, or accept any liability or responsibility in relation to, the adequacy, accuracy, reasonableness or completeness of the information provided as part of this document or any matter on which the information is based (including but not limited to loss or damage arising as a result of reliance by recipients on the information or any part of it). Any liabilities are hereby expressly disclaimed.

Rev	Date	Drn	Chk'd	App'd	Description
M01	27/01/2023	RG	JM	RS	ISSUE FOR PHASE 4: PLANNING

Client: **NTA**
Údarás Náisiúnta Iompair
National Transport Authority

Engineering Designer: **Jacobs**

Date: 27/01/2023
Project Code: BCIDB
Originator Code: JAC

Scales as shown @ A1 as shown @ A3

Drawn: RG
Checked: JM
Approved: RS

QMS Code

Programme Title: **BUSCONNECTS DUBLIN CORE BUS CORRIDORS INFRASTRUCTURE WORKS**

Drawing Title: BRAY TO CITY CENTRE SCHEME
WICKLOW COUNTY COUNCIL
GENERAL ARRANGEMENT
R13-RW017 RETAINING WALL

Drawing File Name: BCIDB-JAC-STR_GA-0013_RW_00-DR-CB-1109
Sheet Number: 01 of 1
Status: A
Rev: M01

DO NOT SCALE USE FIGURED DIMENSIONS ONLY

Appendix B. **Geotechnical Information**



Project No.
20-0399E

Project Name: Bus Connects Route 13 Bray to City Centre

Borehole ID
R13-CP03

Client: National Transport Authority (NTA)

Client's Rep: Jacobs

Method	Plant Used	Top (m)	Base (m)	Coordinates	Final Depth:	Start Date:	Driller:	Sheet 1 of 1
Cable Percussion	Dando 2000	0.00	7.00	726002.77 E 719137.22 N	7.00 m	16/10/2020	BM	Scale: 1:40
					Elevation:	End Date:	Logger:	FINAL
					10.56 mOD	17/10/2020		

Depth (m)	Sample / Tests	Field Records	Casing Depth (m)	Water Depth (m)	Level mOD	Depth (m)	Legend	Description	Water	Backfill
10.46						0.10		TOPSOIL		
0.50	B1							MADE GROUND: Brown very sandy silty subangular to subrounded fine to coarse GRAVEL of mixed lithologies with fragments of red brick. Sand is fine to coarse.		
0.50	ES9									
1.00	B2									
1.00	ES									
1.00	ES10									
1.20	D15					9.36		MADE GROUND: Very soft greyish brown sandy gravelly CLAY with frequent fragments of brick. Sand is fine to coarse. Gravel is subangular fine to coarse of mixed lithologies.		
1.20 - 1.65	SPT (S)	N=2 (0,1/0,1,0,1) Hammer SN = 0643	1.00	Dry						
2.00	B3									
2.00	D16									
2.00	ES11									
2.00 - 2.45	SPT (S)	N=4 (0,1/1,1,1,1) Hammer SN = 0643	1.50	Dry	8.26	2.30		MADE GROUND: Soft brown sandy gravelly CLAY. Sand is fine to coarse. Gravel is subangular fine to coarse of mixed lithologies.		
3.00	B4									
3.00	ES12									
3.00 - 3.45	U20	Ublow=20 100%	1.50	Dry						
4.00	B5									
4.00	D17									
4.00	ES13									
4.00 - 4.45	SPT (S)	N=30 (4,5/7,7,7,9) Hammer SN = 0643	3.00	Dry	7.06	3.50		Very stiff brown slightly sandy slightly gravelly SILT. Sand is fine to coarse. Gravel is subrounded fine to medium of mixed lithologies.		
5.00	B6									
5.00	D18									
5.00	ES14									
5.00 - 5.45	SPT (S)	N=38 (6,6/8,9,9,12) Hammer SN = 0643	3.00	Dry	5.06	5.50		Dense brown sandy silty subrounded fine to coarse GRAVEL of mixed lithologies. Sand is fine to coarse.		
6.00	B7									
6.00 - 6.45	U21	Ublow=50 60%	3.00	Dry	4.06	6.50		Dense brown gravelly clayey fine to coarse SAND. Gravel is subrounded fine to coarse of mixed lithologies.		
7.00	B8									
7.00	D19									
7.00 - 7.38	SPT (S)	N=50 (9,11/50 for 225mm) Hammer SN = 0643	3.00	Dry	3.56	7.00		End of Borehole at 7.00m		

Water Strikes				Chiselling Details			Remarks
Struck at (m)	Casing to (m)	Time (min)	Rose to (m)	From (m)	To (m)	Time (hh:mm)	
							Hand dug inspection pit excavated to 1.20m.
Casing Details		Water Added					
To (m)	Diameter	From (m)	To (m)				
Termination Reason							Last Updated
Terminated on refusal.							17/12/2020





Appendix F2
St Laurence Subway
Preliminary Design Report

© Copyright 2023 Jacobs Engineering Ireland Limited. The concepts and information contained in this document are the property of Jacobs. Use or copying of this document in whole or in part without the written permission of Jacobs constitutes an infringement of copyright.

Limitation: This document has been prepared on behalf of, and for the exclusive use of Jacobs' client, and is subject to, and issued in accordance with, the provisions of the contract between Jacobs and the client. Jacobs accepts no liability or responsibility whatsoever for, or in respect of, any use of, or reliance upon, this document by any third party.

**Preliminary Design Report-
Consultation**

STA-1b

Categories 1, 2 & 3

Scheme Name

Name and Location – BusConnects Route 13 Bray to City Centre, Dublin

Structure(s)

Name and nature of the Structure(s) – St Laurence Park Subway

Preliminary Design Report

Reference - DR-N11-007.00

Revision - M01

Date - 31st March 2023

Submitted by

Signed 

Name John McElhinney

Position Structural Discipline Lead (Team Leader)

Organisation Jacobs Engineering

Date 31/03/2023

Structures Section confirmation of consultation

Signed 

Name Liam Duffy

Position Senior Engineer Structures

Date 5 April 2023

* This application should appear as the first page after the cover of the Preliminary Design Report.

Contents

1.	Introduction.....	1
1.1	Brief.....	1
1.2	Background.....	1
1.3	Previous Studies.....	2
2.	Site & Function.....	3
2.1	Site Location.....	3
2.2	Function of Site and Obstacles Crossed.....	3
2.3	Choice of location.....	3
2.4	Site Description and Topography.....	3
2.5	Vertical and Horizontal Alignments.....	4
2.6	Cross Sectional Dimensions.....	4
2.7	Existing Underground and Overground Services.....	4
2.8	Geotechnical Summary.....	5
2.9	Hydrology and Hydraulic Summary.....	6
2.10	Archaeological Summary.....	6
2.11	Environmental Summary.....	6
3.	Structure & Aesthetics.....	7
3.1	General Description of Recommended Structure and Design Working Life.....	7
3.2	Aesthetic Considerations.....	7
3.3	Proposals for the Recommended Structure.....	8
3.3.1	Proposed Category.....	8
3.3.2	Span Arrangement.....	8
3.3.3	Minimum Headroom Provided.....	8
3.3.4	Approaches including run-on arrangements.....	8
3.3.5	Foundation Type.....	9
3.3.6	Substructure.....	9
3.3.7	Superstructure.....	9
3.3.8	Articulation Arrangement.....	9
3.3.9	Vehicle Restraint System.....	9
3.3.10	Drainage.....	9
3.3.11	Durability.....	9
3.3.12	Sustainability.....	10
3.3.13	Inspection and Maintenance.....	10
4.	Safety.....	11
4.1	Traffic Management during Construction.....	11
4.2	Safety during Construction.....	11
4.3	Safety in Use.....	11
4.4	Lighting.....	11
5.	Design Assessment Criteria.....	12
5.1	Actions.....	12

5.1.1	Permanent Actions.....	12
5.1.2	Snow, Wind and Thermal Actions.....	12
5.1.3	Actions Relating to Normal Traffic	12
5.1.4	Actions Relating to Abnormal Traffic.....	12
5.1.5	Footway or Footbridge Live Loading.....	12
5.1.6	Provision for Exceptional Abnormal Loads.....	12
5.1.7	Accidental Actions.....	12
5.1.8	Actions during Constructions.....	12
5.1.9	Any Special Loading not Covered Above.....	12
5.2	Authorities consulted and any special conditions required.....	13
5.3	Proposed Departures from Standards	13
5.4	Proposed methods of dealing with aspects not covered in standards.....	13
6.	Ground Conditions.....	14
6.1	Geotechnical Classification	14
6.2	Ground Conditions	14
7.	Drawings and Documents	16
7.1	List of All Documents Accompanying the Submission.....	16

1. Introduction

1.1 Brief

Jacobs have been appointed by the National Transport Authority (NTA) to undertake the Engineering Design Services for the Planning Stage through to the end of the Statutory Process of the BusConnects Radial Core Bus Corridors Infrastructure Upgrade Programme (the Programme). The Project has been split in four packages with Jacobs undertaking Package B.

This report outlines the Preliminary Design for the St Laurence Park Subway at N11 Stillorgan Road on Core Bus Corridor (CBC) 13 Bray to City Centre. The other routes undertaken by Jacobs shall be covered in separate reports.

1.2 Background

The National Transport Authority (NTA) published the Transport Strategy for the Greater Dublin Area, 2016 – 2035 at the beginning of 2016. The strategy identifies a “Core Bus Network”, representing the most important bus routes within the Greater Dublin area, generally characterised by high passenger volumes, frequent services, and significant trip attractors along the routes. The identified core network comprises sixteen radial bus corridors, three orbital bus corridors and six regional bus corridors.

The Strategy states that it is intended to provide continuous bus priority, as far as is practicable, along the core bus routes. This will result in a more efficient and reliable bus service with lower journey times, increasing the attractiveness of public transport in these areas and facilitating a shift to more sustainable modes of transport. The Bray to City Centre Core Bus Corridor is identified as part of the Core Bus Network.

In March 2018, BusConnects Dublin was launched as part of major investment programme, including Metrolink and the Dublin Area Rapid Transport (DART) Expansion Programme, to improve public transport in Dublin, as part of the National Development Plan 2018-2027. The Bray to City Centre CBC serves the area to the south of Dublin city, creating an improved public transportation link for areas along the corridor.



Figure 1.1: BusConnects Dublin Radial CBC Network

1.3 Previous Studies

The first non-statutory public consultation on the BusConnects CBCs took place on a phased basis between November 2018 and May 2019. The second round of public consultations occurred between March 2020 and April 2020. A third round of public consultations then followed between November 2020 and December 2020.

Consultation with the principal project stakeholders (i.e. Dublin City Council, Transport Infrastructure Ireland, Utility companies and the National Transport Authority) has also taken place.

2. Site & Function

2.1 Site Location

The structure (Ref: DR-N11-007.00) is located approximately 9 km south of Dublin City Centre (ITM Grid Reference: E720235, N728182). Structure comprises of a precast concrete box culvert with a span of 3.72 m, length of approximately 31 m and has a 13° skew.

The structure is owned by Dún Laoghaire-Rathdown Council (DLRCC), but it is managed and maintained by Transport Infrastructure Ireland Regional Bridge Management.

The proposed alignment and cross section of road as part of the BusConnects CBC13 works requires the widening of the structure.

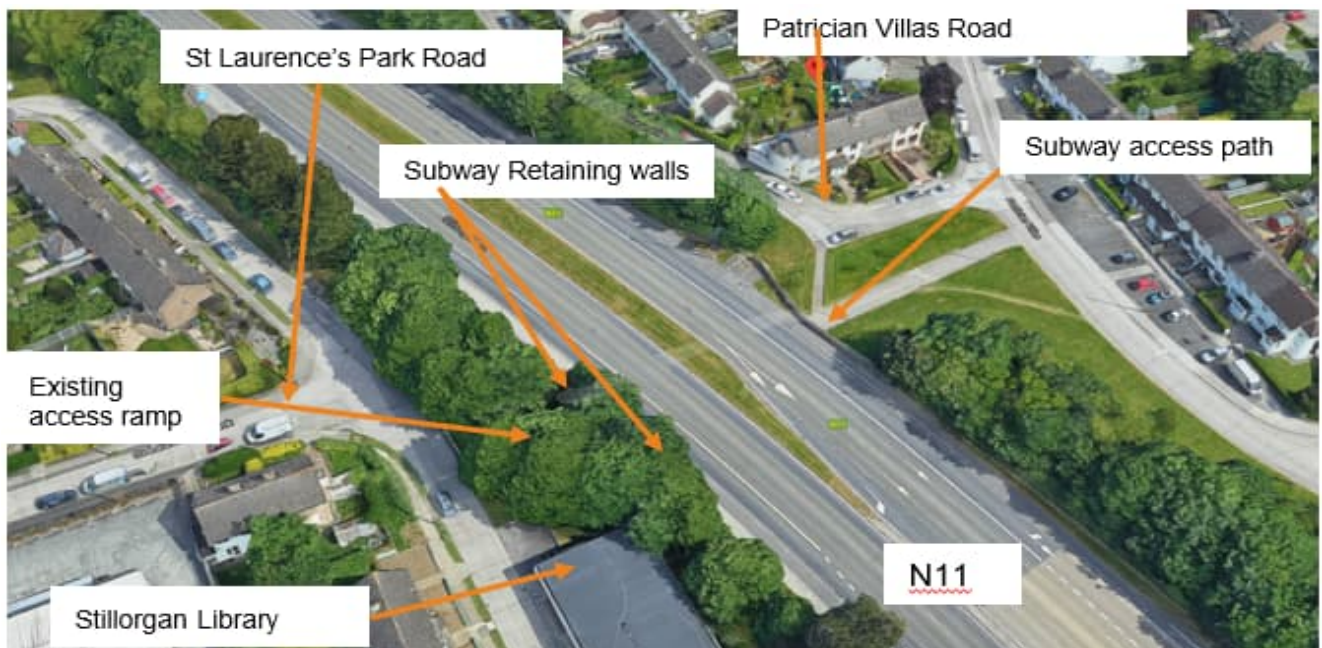

Figure 2.1: Site Location Plan

2.2 Function of Site and Obstacles Crossed

St Laurence Park Subway is an existing structure which carries the N11 over a pedestrian link between St Laurence's Park and Patrician Villas. The existing carriageway has 6 lanes of traffic with a footway on the west side and a raised cycle track on the east side directly adjacent to the carriageway.

2.3 Choice of location

The location of the structure is governed by the alignment of the N11 and the interface with the access ramps. The structure is located within the boundaries DLRCC.

2.4 Site Description and Topography

The site on the west side is constrained by the existing planted slope and adjacent local road at higher level. A public library located close to the western retaining wall will need to be taken into consideration.

On the east side there is greater room for future construction with the approach to the underpass being an area of open grassland owned by DLRCC. The presence of this green space provides the opportunity to widen the subway in this direction.

A grass area immediately adjacent to the west approach ramp is currently proposed for development by DLRCC as a mixed-use site including apartments and a new library.

2.5 Vertical and Horizontal Alignments

The vertical and horizontal alignment over the structure is proposed to have a slight realignment from the existing arrangement. The northbound carriageway is proposed to be shifted 0.5m to the east to accommodate the new cycleway. The central verge kerblines for the southbound carriageway is unchanged from existing.

Refer to the road design drawings for the proposed vertical and horizontal road alignments along the scheme.

2.6 Cross Sectional Dimensions

The existing and proposed highway cross sections are described in Table 2.1 below.

Existing Cross Section		Proposed Cross Section	
West footway	2.6m	West footway	1.7m
Northbound bus lane	3.0m	West cycleway	2.0m
West carriageway	7.8m	Northbound bus lane	3.0m
Central reserve	4.8m	West carriageway	7.2m
East carriageway	7.3m	Central reserve	4.1m
Southbound bus lane	3.4m	East carriageway	7.7m
East footway	2.2m	Southbound bus lane	3.1m
		East cycleway	2.2m
		East footway	1.9m
Total	31.1m	Total	32.9m

Table 2.1: Comparison of existing and proposed cross-sections

Please refer to drawing BCIDB-JAC-STR-GA-0013-BR-00-DR-CB-0001 in Appendix A – Drawings for the cross-sectional dimensions of St Laurence Subway.

2.7 Existing Underground and Overground Services

There are several existing utility assets located above and around the existing St Laurence Park Subway as well as under the approaches to the east and west of the structure.

There are ESB 220kV transmission cables located in the existing central median. GPR survey and slit trenches have proven that these cables are located in the median close to the south bound kerb line and encased in concrete. The cables have reduced cover where they cross over the existing subway and further protection is afforded by the existence of large steel sheets on top of the concrete encasement. The depth of cover to the steel sheets is circa 230mm from existing surface levels. These cables are of strategic importance to the ESB transmission network. Any works within 15m will require co-ordination with ESB as the asset owner.

There is a 600mm diameter storm water pipe that crosses the existing carriageway at a depth of circa 5.0m in close proximity and parallel to the existing structure. This appears to be installed in the backfill of the existing underpass and passes beneath the existing wing walls. The drainage should be located prior to construction to determine depth and if required should be accommodated within the new construction.

There is a high-pressure gas main to the east of the structure in the green space where the existing approach ramps are located. This asset is located outside of the construction footprint.

There are several EIR assets running immediately adjacent to the existing parapet wall over the structure. These will not be impacted during the proposed works.

A summary of the identified existing utilities that may require diversion/accommodation can be seen in Table 2.2. In addition to those listed, spare ducts should be provided where practical for future use and to accommodate any unforeseen utilities encountered.

Asset Owner	Details	Location	Diversion Required
ESB	5 No. 125mm ducts for HV and dedicated fibre	Over structure in central median close to southbound kerb line	No, assets to remain in place. Work within exclusion zone. Must be protected.
ESB	LV	Running parallel to north abutment	Yes, asset to be protected and alignment modified to suit arrangement at east side of structure.
Storm Water	600mm dia. Concrete	Adjacent and parallel to existing underpass	No. Retain in situ.
EIR	Unidentified	Located in west footway	No, assets to remain in place
EIR	Unidentified	Located in east footway	No, assets to remain in place
EIR	Unidentified	Located east of structure	Yes, asset to be protected and alignment modified to suit arrangement at east side of structure.
Virgin Media	Unidentified	Located in west footway	No, assets to remain in place.
GNI	HP	Located east of the structure	No, assets to remain in place. Work within exclusion zone.
GNI	LP	Located west of structure	No, assets to remain in place. Work within exclusion zone.
Irish Water	Foul	Located west of the structure in St Laurence Park	No, asset to remain in place.

Note: Utilities listed do not include domestic / privately owned services and street lighting cables.

Table 2.2: Summary of utilities subject to diversion

2.8 Geotechnical Summary

A geotechnical desktop study of the area has been undertaken using publicly available information and Ground Investigation reports available through the Geological Survey of Ireland. Where identified, supplementary GI information was requested to increase the understanding of the geological conditions at targeted locations across the scheme.

Refer to Section 7 for details of the ground conditions at the structure location.

2.9 Hydrology and Hydraulic Summary

It is not expected that the construction of the proposed subway will have any significant impact on the local hydrogeology.

2.10 Archaeological Summary

There are no recorded areas of significant archaeological importance in the vicinity of St Laurence Subway.

2.11 Environmental Summary

There are banks of trees located on both sides of the N11 Stillorgan Road close to the subway structure. There will be some tree losses to the eastern side of the roadway. An arboricultural survey has categorised these tree groups adjacent to the highway as 'B' grade. Due to the extent of trees with a 'B' grade in the area, the removal of some trees within the linear belt to accommodate the structure and potential step and ramp arrangements is not considered to be significant. New tree planting will help mitigate landscape losses and tie the proposals back into the existing fabric. It is not expected that the works will result in a total loss of screening to the properties in Patrician Villas or that any requirement for tree removal during construction will have a significant impact on this function.

Ecological assessment of these trees has been undertaken and it has been found that the trees are not considered to be of major significance with this regard.

Aside from the proposed impacts to trees, it is not considered that the proposed structure will have a significant impact on any other aspects of the environment. There are no water courses or ecologically designated sites close to the structure.

An Environmental Impact Assessment (EIA) is currently being prepared for the scheme on behalf of the Employer. Outcomes from this EIA will be reviewed and incorporated once determined.

3. Structure & Aesthetics

3.1 General Description of Recommended Structure and Design Working Life

The design proposes the widening of the existing subway to the east by approximately 2.95m to accommodate the proposed footway on the eastern southbound side of the structure. The northbound carriageway, cycleway and footway will be accommodated with a local reduction of median width by approximately 0.5m. The widened structure comprises of an in-situ box construction which will be connected to the existing structure via post installed dowels to minimise the risk of differential settlement between the old and new structures.

New proposed wing walls would be constructed to the east of and parallel to the existing wing walls. The existing wing walls would retain the carriageway during construction activities reducing the need for temporary works. This removes the need to excavate into the carriageway and reduces the needs for utilities diversions. Once the new wing walls are constructed the space between the new and existing walls would be backfilled. The existing wall would be partially demolished such that the remaining sections are under the sub-base of the surfacing. As the existing wall would then be surrounded by fill it is no longer required to resist any loading and can be left in-situ without concern. As a result of this the existing subway would need to be widened to a slightly greater extent than that which would be required for the proposed highway alignment alone. Nonetheless, the benefits in ease of construction outweigh the additional material usage.

The subway and wing walls are proposed to be connected via dowel connections. This would allow transfer of loading between elements and allow for global contribution increasing the amount of resistance during an impact load, and increasing the bearing area. This would improve the performance of the new extension in comparison to an independent arrangement.

Detailed design of widening to the existing subway would be undertaken following the requirements of DN-STR-03019-01 "Treatment of Widening of Existing Structures". The structural details and load rating of the existing underpass are not known. Structural investigative works are proposed to be undertaken prior to the detailed design. A Stage 1 assessment of the underpass to AM-STR-06026-02 and AM-STR-06056 will be undertaken as part of the detailed design, based on the findings of the investigative works proposed. Whilst it is not anticipated that the widening of the structure would impact adversely on the existing underpass and foundations, this would be subject to review and confirmation in the detailed design.

Design working life of 120 years is recommended to be used in this design.

3.2 Aesthetic Considerations

St Laurence Subway does not have a significant presence in the local area in its current arrangement with only the east elevation being clearly visible from the approaches. The existing retaining walls comprise of masonry pilasters with a profiled rendered finish at intervals. The parapet will need to be reinstated to a height of 1.4m and should maintain a similar masonry appearance.

This existing subway has artwork decorating the interior of the structure, see Figure 3.1. Numerous locations in the interior of the structure have been subjected to graffiti. Consideration should be given to painting the interior of the box in a colourful patterned finish or a piece of commissioned artwork to improve the appeal of use of the subway. These measures would aim to help decrease the risk of vandalism through graffiti. It should be noted that hydrophobic pore liners may impact the suitability of water-based paint systems.

Landscaping to the areas east of the structure should be updated to reflect the new arrangement of the approach ramps.



Figure 3.1: Interior of St Laurence Subway (November 2019)

3.3 Proposals for the Recommended Structure

3.3.1 Proposed Category

The buried concrete structure has a span between 3-7m and the retained height of all the walls is smaller than 5m, hence the structure is classified as a Category 1 structure in accordance with DN-STR-03001.

3.3.2 Span Arrangement

New section maintains existing span of 3.72m.

3.3.3 Minimum Headroom Provided

Existing headroom of approx. 2.5m to be maintained, height to be confirmed by investigation of existing structure prior to detailed design.

3.3.4 Approaches including run-on arrangements

Approaches to the subway will tie into existing pedestrian infrastructure providing a maximum gradient of 1 in 20. It is not anticipated that the proposed works will drastically impact the arrangement to the east of the existing structure.

3.3.5 Foundation Type

Proposed structure will be founded on spread footings bearing onto a suitable bedding material.

3.3.6 Substructure

Not applicable.

3.3.7 Superstructure

Not applicable.

3.3.8 Articulation Arrangement

The widened section of the box structure will be connected to the existing structure via post installed dowels to control differential settlement and remove the requirement for a joint.

Nominal 20mm vertical movement joints will be used between sections of the wing walls to allow for natural expansion and contraction of the concrete. Stainless steel dowel bars will be used to control differential displacement of the wall sections.

3.3.9 Vehicle Restraint System

A 1.4m reinforced concrete parapet is proposed on the eastern side of the structure to be designed in accordance with DN-REQ-03034.

No modifications are proposed for the western parapet.

3.3.10 Drainage

A permeable drainage layer will be provided behind the wing walls in accordance with CC-SPW-00500 and will provide a positive outfall into existing surface water drainage infrastructure to the west of the construction footprint. Modification of the existing surface water drainage infrastructure may be required if proposed founding level of the widened structure clashes. This will be confirmed via surveys in the next stage of design.

No weepholes will be provided in the face of the new wing wall as per standard TII practice. Prior to the construction of the new wing walls the existing walls shall be punctured at regular spacings to prevent build-up of hydrostatic pressure behind the existing asset and allow free draining into the newly proposed draining layers.

3.3.11 Durability

The top surface of the box, and the top of the adjoining vertical external surfaces to a level of 200mm below the soffit of the top slab, shall be protected with a suitable waterproofing system. The upper surface of the bottom slab shall also be treated with a bridge deck waterproofing system. The waterproofing system shall be a proprietary spray applied system in accordance with DN-STR-03009- Waterproofing and Surfacing of Concrete Bridge Decks and CC-SPW-02000- Specification for Road Works Series 2000- Waterproofing for Concrete Structures.

Concrete below ground level will be treated with two coats epoxy resin waterproofing in accordance with DN-STR-03012.

All exposed concrete in the substructure shall be impregnated with a hydrophobic pore liner in accordance with DN-STR-03012. This will improve the ability of the structure to resist water and chloride incursion. Further consideration of this would be required at detailed design if a graffiti finish is preferred as the pore liner may interfere with the suitability of water based paint systems in this use case.

3.3.12 Sustainability

Recycled GGBS will be used in the design and construction of some of the structures concrete elements leading to a more sustainable structure overall.

3.3.13 Inspection and Maintenance

The design will require an inspection and maintenance regime to comply with TII requirements for management of bridge structures. This would involve a schedule of inspections at regular intervals and construction dependant maintenance regimes.

Regular painting of the interior of the subway is required to remove the anticipated graffiti. The Lighting apparatus would require periodic replacement of lamps to maintain the lighting requirement within the structure.

Given the urban setting of this structure and the presence of graffiti on the existing structure, the abutments and the bridge are considered at high risk of being subjected to similar graffiti. Consideration should therefore be given to finishing the substructure and superstructure with an anti-graffiti coating.

4. Safety

4.1 Traffic Management during Construction

To be developed at a further stage of the design. It is anticipated that the pedestrian / cycleway through the structure will be closed for the duration of the construction works.

4.2 Safety during Construction

The Designer will take account of the General Principles of Prevention, as specified in the Schedule 3 of the Safety, Health and Welfare at Work Act 2005, liaise with the Project Supervisor appointed by the Client for the Design Process and the Project Supervisor appointed for the Construction Stage and carry out all other duties as required by Clause 15 of the Safety, Health and Welfare at Work (Construction) Regulations 2013 (S.I. No. 291 of 2013).

4.3 Safety in Use

Pedestrian Guardrails compliant with DN-REQ-03034 to be provided at the end of the wing walls to tie in with the guardrails provided at back of east verge

4.4 Lighting

Lighting shall be provided along the soffit of the new sections of subway and should be of similar appearance to the existing arrangement. Consideration should be given to the complete replacement of the existing lighting apparatus to create a consistent appearance throughout the structure.

5. Design Assessment Criteria

5.1 Actions

Design actions to be applied to the structural widening. Assessment of the existing structure will be to the requirements of AM-STR-06026-02

5.1.1 Permanent Actions

Permanent actions in accordance with IS EN 1991-1-1:2002 and the associated National Annex.

5.1.2 Snow, Wind and Thermal Actions

Snow actions are not considered in the design. Snow load is ignored in accordance with National Annex to IS EN 1990:2002.

Wind actions shall be in accordance with IS EN 1991-1-4 and the associated National Annex.

Thermal actions will be assessed in accordance with IS EN 1991-1-5 and the associated National Annex.

5.1.3 Actions Relating to Normal Traffic

Traffic loading is in accordance with IS EN 1991-2 and the associated National Annex to IS EN 1991-2. Combinations of actions shall be in accordance with the National Annex to IS EN 1990:2002 and as outlined in PD 6694-1.

5.1.4 Actions Relating to Abnormal Traffic

The structure will be designed for SV196 Load Model 3 as per the requirements of GE-POL-01008 and as defined in the Irish national Annex to I.S. EN 1991-2.

5.1.5 Footway or Footbridge Live Loading

Footpath live loading shall be applied above the wall in accordance with Clause 5.3.2 of IS EN 1991-2 and its associated National Annex.

5.1.6 Provision for Exceptional Abnormal Loads

Exceptional abnormal loads not considered.

5.1.7 Accidental Actions

Not applicable.

5.1.8 Actions during Constructions

Not applicable.

5.1.9 Any Special Loading not Covered Above

A transient surcharge load will be applied to the ground behind the walls. The following non-concurrent loads have been considered in the design depending on the slope of the ground level behind the wall:

- 10 kPa Construction Surcharge (ground profile level behind the wall)
- 10 kPa Design Surcharge for slopes $\beta \leq 1V:6H$
- 5.0 kPa Design Surcharge for slopes $1V:6H < \beta \leq 1V:3H$
- 2.5 kPa Design Surcharge for slopes $\beta > 1V:3H$

5.2 Authorities consulted and any special conditions required

Principal project stakeholders have been consulted:

- Dún Laoghaire-Rathdown County Council;
- Transport Infrastructure Ireland;
- National Transport Authority.

The following utilities companies were consulted with on a scheme wide basis:

- ESB;
- GNI;
- Irish Water;
- Eir;
- Virgin Media.

5.3 Proposed Departures from Standards

These are no proposed departures from standards for these structures.

5.4 Proposed methods of dealing with aspects not covered in standards

Not applicable.

6. Ground Conditions

6.1 Geotechnical Classification

The subway structure is considered Geotechnical Classification 2.

6.2 Ground Conditions

Ground conditions at the structure location have been assessed using publicly available information including geological maps, publicly available ground investigations and historic mapping. Additionally, a cable percussion borehole, R13-CP01 of Bus Connects Route 13 Bray to City Centre – Ground Investigation (Appendix B) was put down at the western side of the subway. The geology of the area is comprised of made ground overlying Glacial Till comprised of firm to very stiff slightly sandy, gravelly clay. Made ground 1.2m in thickness was recorded within the borehole, it is anticipated that the depth of made ground will vary across the site with varying ground levels.

The borehole refused on suspected bedrock at 4.8m bgl (44.2m AOD). Bedrock is comprised of Type 2p microcline porphyritic granite with microcline phenocrysts. It is anticipated that the structure will be founded on very stiff Glacial Till or bedrock. Historic ground investigations available to the west of the site also indicate relatively shallow bedrock between 5m and 9m bgl.

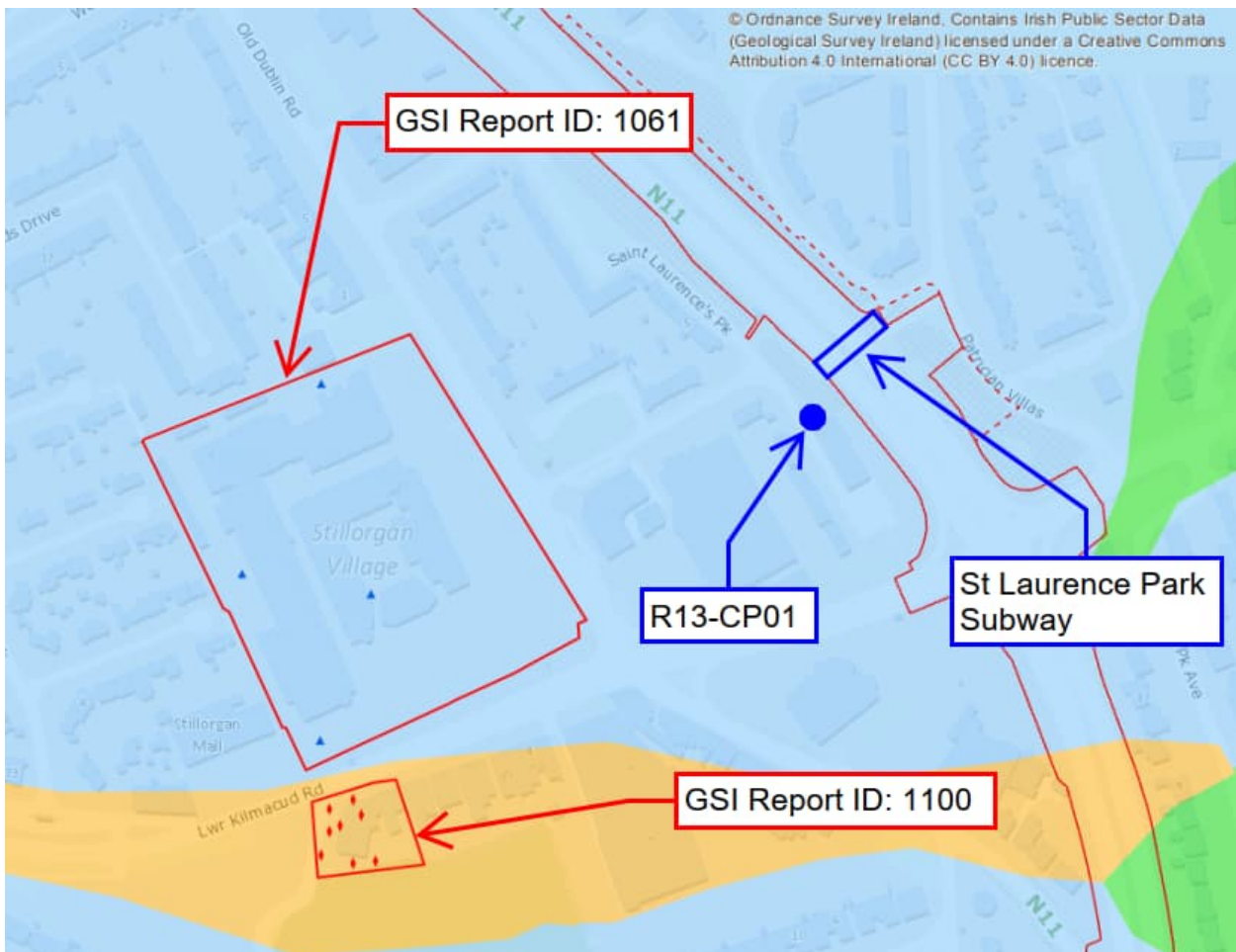

Figure 6.1 Location of GI Information

There is no information to confirm the composition of the slopes on the east of the subway, however it is expected these slopes will be comprised of made ground and/or glacial till overlying granite bedrock.

It is assumed that if bedrock levels are consistent in this area, foundations for the structural widening can be founded on bedrock. If bedrock is significantly variable, the firm to very stiff Dublin Boulder Clay should provide a suitable founding stratum. A site survey, refer to Appendix B, should be undertaken before the commencement of detailed design to determine the properties of the existing subway structure. The survey should include investigation of the existing subway and wing wall foundations. Additional ground investigation on the east side of the subway is also recommended prior to detailed design to confirm the ground conditions.

7. Drawings and Documents

7.1 List of All Documents Accompanying the Submission

Drawing Reference	Drawing Title	Revision
BCIDB-JAC-STR_GA-0013_XX_00-DR-SS-0020	Site Location Plan	M01
BCIDB-JAC-STR-GA-0013-BR-00-DR-CB-0001	General Arrangement Sheet 1 of 2	M01
BCIDB-JAC-STR-GA-0013-BR-00-DR-CB-0002	General Arrangement Sheet 2 of 2	M01

Table 7.1: List of accompanying drawings

Relevant documents are included as appendices to this report.

Appendix A. **Drawings**

0 5.0 10.0 20.0 30.0 40.0 50.0m

SCALE 1:500 @ A1; 1:1000 @ A3

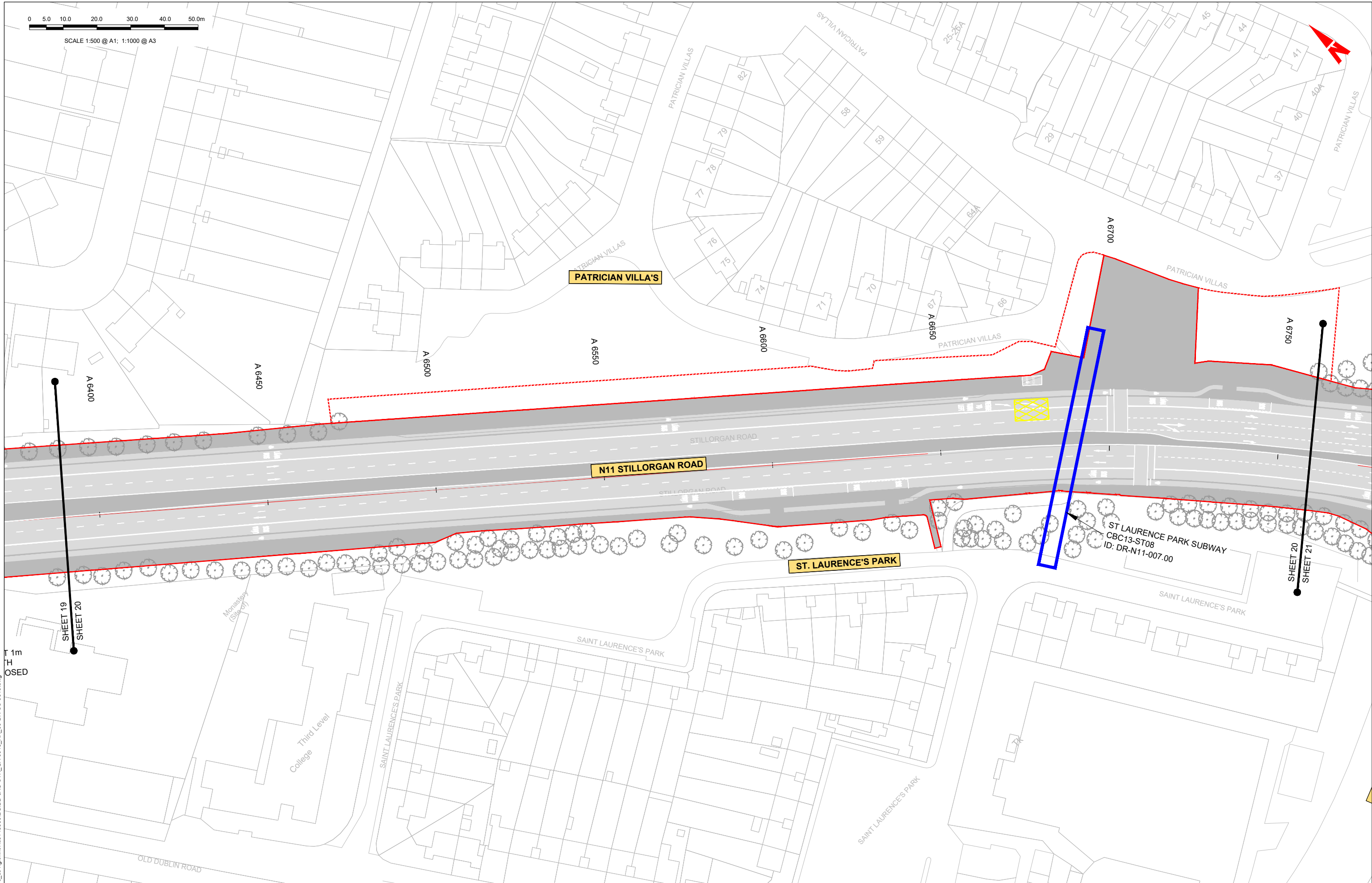

T 1m
H
OSD

C:\pwworking\jacobs_uk_highways_ss4\glennor\0148698\BCIDB-JAC-STR_GA-0013_XX_00-DR-SS-0016.dwg

Disclaimer

a. © National Transport Authority (NTA) 2022. This drawing is confidential and the copyright in it is owned by NTA. This drawing must not be either loaned, copied or otherwise reproduced in whole or in part or used for any purpose without the prior permission of NTA.

b. This drawing is to be used for the design element identified in the titleblock. Other information shown is to be considered indicative only. The drawing is to be read in conjunction with all other relevant design drawings.

c. O.S. data used for plans are printed under © Ordnance Survey Ireland Government of Ireland. All rights reserved. Licence Number 2022/OS_NMA_180 National Transport Authority. All elevations are in metres and relate to OSI Geoid Model (OSGM15) Mean Head. All Co-ordinates are in Irish Transverse Mercator Grid (ITM) as defined by OSI active local GPS station.

d. Information concerning the position of apparatus shown on this drawing is based on drawings supplied by the utility owners and/or the utility works contractor, whilst every care has been taken in the preparation of this drawing, positions should be taken as approximate and are intended for general guidance only and no representation is made by the NTA as to the accuracy, completeness, sufficiency or otherwise of this drawing and the position of the apparatus. The information contained herein does not purport to be comprehensive or final as the apparatus is subject to being altered and/or superseded. Recipients should not rely on this information. Any liabilities are hereby expressly disclaimed.

e. The information contained herein has been provided by the NTA but does not purport to be comprehensive or final. Recipients should not rely on the information. Neither the NTA nor any of its directors, officers, employees, agents, stakeholders or advisers make any representation or warranty as to, or accept any liability or responsibility in relation to, the adequacy, accuracy, reasonableness or completeness of the information provided as part of this document or any matter on which the information is based (including but not limited to loss or damage arising as a result of reliance by recipients on the information or any part of it). Any liabilities are hereby expressly disclaimed.



Rev	Date	Drn	Chk'd	App'd	Description
M01	27/01/2023	RG	JM	RS	ISSUE FOR PHASE 4: PLANNING

Client
NTA
Údarás Náisiúnta Iompair
National Transport Authority

Date: 27/01/2023
Scale: 1:500 @ A1
1:1000 @ A3

Project Code: BCIDB
Originator Code: JAC

Engineering Designer
Jacobs

Drawn: RG
Checked: JM
Approved: RS

QMS Code

Programme Title
**BUSCONNECTS DUBLIN
CORE BUS CORRIDORS INFRASTRUCTURE WORKS**

Drawing Title
BRAY TO CITY CENTRE SCHEME
STRUCTURES GENERAL ARRANGEMENT

Drawing File Name: BCIDB-JAC-STR_GA-0013_XX_00-DR-SS-0020
Sheet Number: 20 of 54
Status: A
Rev: M01

DO NOT SCALE USE FIGURED DIMENSIONS ONLY

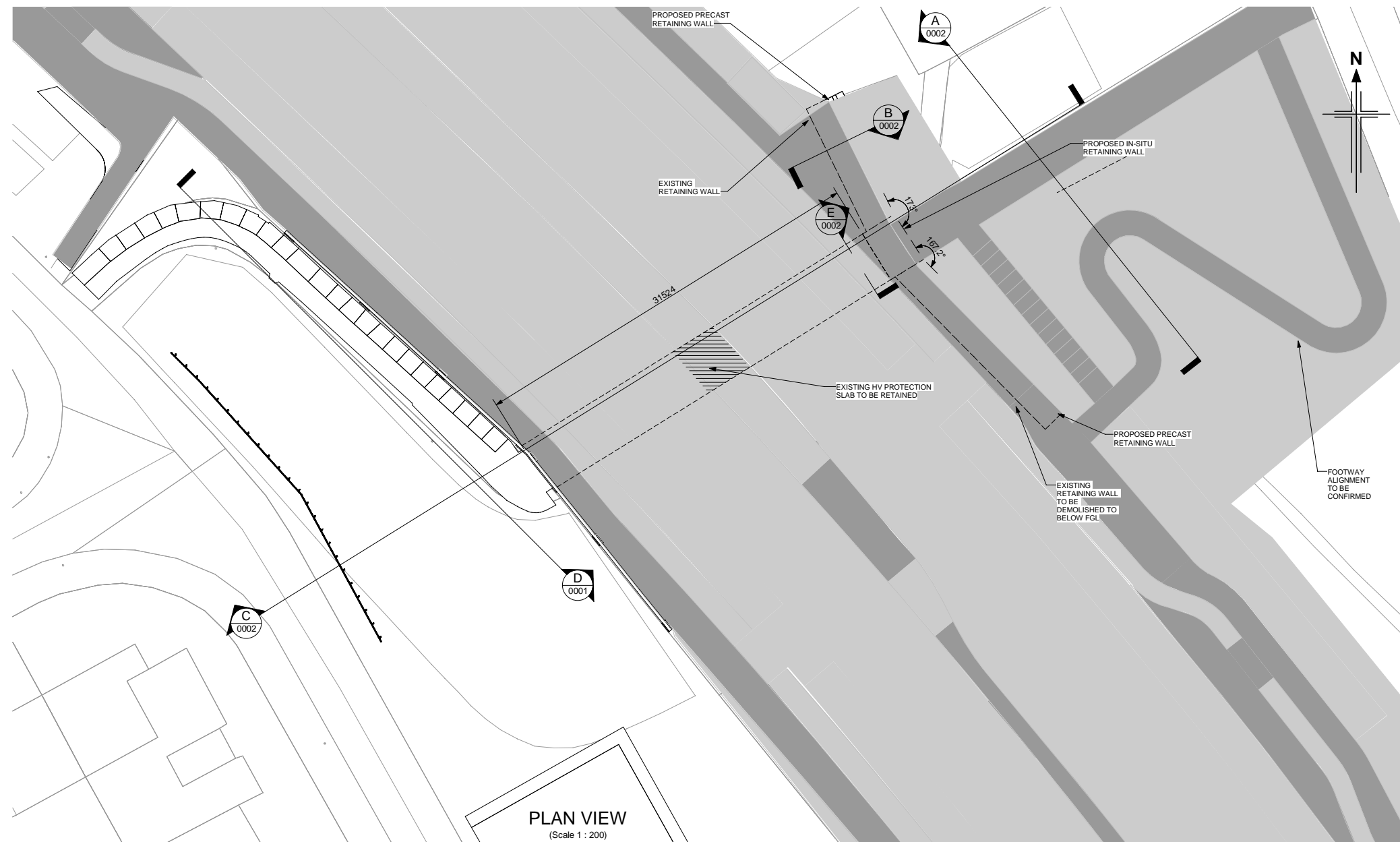

PLAN VIEW
(Scale 1 : 200)

- NOTES:**
1. ALL DIMENSIONS ARE IN MILLIMETRES UNLESS NOTED OTHERWISE.
 2. ALL LEVELS AND CHAINAGES ARE IN METRES UNLESS NOTED OTHERWISE.
 3. ALL EXPOSED ARISES TO HAVE 25x25 CHAMFERS UNLESS NOTED OTHERWISE.

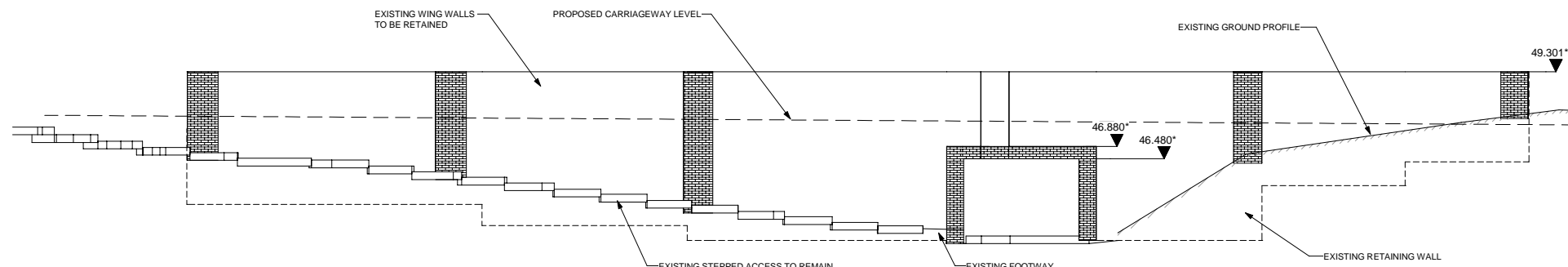

SECTION D-D
(Scale 1 : 100)

Disclaimer

a. © National Transport Authority (NTA) 2021. This drawing is confidential and the copyright in it is owned by NTA. This drawing must not be either loaned, copied or otherwise reproduced in whole or in part or used for any purpose without the prior permission of NTA.

b. This drawing is to be used for the design element identified in the titlebox. Other information shown is to be considered indicative only. The drawing is to be read in conjunction with all other relevant design drawings.

c. O.S. data used for plans are printed under © Ordnance Survey Ireland Government of Ireland. All rights reserved. Licence Number 2021/OSI_NMA_180 National Transport Authority. All elevations are in metres for any purpose without the prior permission of NTA. Transverse Mercator Grid (ITM) as defined by OSI active local GPS station.

d. Information concerning the position of apparatus shown on this drawing is based on drawings supplied by the utility owners and/or the utility works contractor, whilst every care has been taken in the preparation of this drawing, positions should be taken as approximate and are intended for general guidance only and no representation is made by the NTA as to the accuracy, completeness, sufficiency preparation of this drawing, positions should be taken as approximate and are intended for general guidance only and no representation is made by the NTA as to the accuracy, completeness, sufficiency or otherwise of this drawing and the position of the apparatus. The information contained herein does not purport to be comprehensive or final as the apparatus is subject to being altered and/or superseded. Recipients should not rely on this information. Any liabilities are hereby expressly disclaimed.

e. The information contained herein has been provided by the NTA but does not purport to be comprehensive or final. Recipients should not rely on the information. Neither the NTA nor any of its directors, officers, employees, agents, stakeholders or advisers make any representation or warranty as to, or accept any liability or responsibility in relation to, the adequacy, accuracy, reasonableness or completeness of the information provided as part of this document or any matter on which the information is based (including but not limited to loss or damage arising as a result of reliance by recipients on the information or any part of it). Any liabilities are hereby expressly disclaimed.



Rev	Date	Dwn	Chk'd	App'd	Description
M01	27/01/2023	RG	JM	RS	ISSUE FOR PHASE 4: PLANNING

Date	Scale	Drawn	Checked	Approved
27/01/2023	As indicated @ A1	RG	JM	RS
Project Code	Originator Code	GMS Code		
BCIDB	JAC			

BUSCONNECTS DUBLIN CORE BUS CORRIDORS INFRASTRUCTURE WORKS			
Drawing title BRAY TO CITY CENTRE SCHEME ST LAURENCE SUBWAY WIDENING GENERAL ARRANGEMENT SHEET 1 OF 2			
Drawing File Name	Sheet Number	Status	Rev
BCIDB- JAC- STR_GA- 0013_BR_00- DR- CB- 0001	1 of 2	A	M01

DO NOT SCALE USE FIGURED DIMENSIONS ONLY

c:\working\jacobson_uk_highways_saf\generat\46705BCIDB-JAC-STR_GA-0013_BR_00-DR_CB-0001.rvt

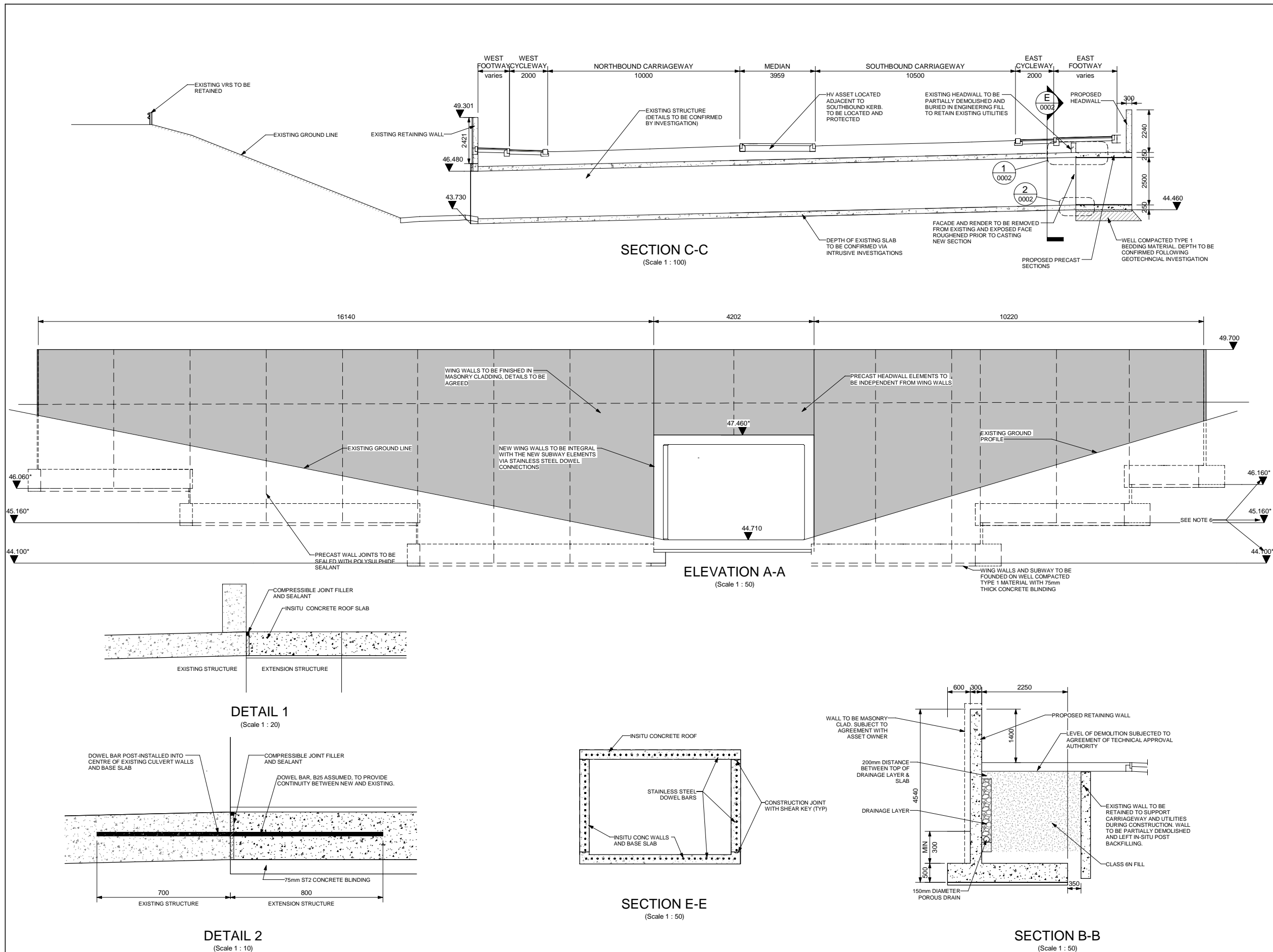

- NOTES:**
1. ALL DIMENSIONS ARE IN MILLIMETRES UNLESS NOTED OTHERWISE.
 2. ALL LEVELS AND CHAINAGES ARE IN METRES UNLESS NOTED OTHERWISE.
 3. ALL EXPOSED ARISES TO HAVE 25x25 CHAMFERS UNLESS NOTED OTHERWISE.
 4. INSTALL WATERPROOFING HYDROPHILIC PROFILE AND SEALANT ALONG FULL LENGTH JOINT BETWEEN EXISTING AND NEW BOX SECTION.
 5. DOWEL BARS TO BE INSTALLED IN THE CENTRE OF THE EXISTING WALL AND BASE SLAB USING AN ADHESIVE BONDING MATERIAL
 6. LEVELS INDICATED THUS * ARE ASSUMED LEVELS BASED ON TOPOGRAPHICAL SURVEY. TO BE CONFIRMED ON SITE.

Disclaimer

a. © National Transport Authority (NTA) 2021. This drawing is confidential and the copyright in it is owned by NTA. This drawing must not be either loaned, copied or otherwise reproduced in whole or in part or used for any purpose without the prior permission of NTA.

b. This drawing is to be used for the design element identified in the titlebox. Other information shown is to be considered indicative only. The drawing is to be read in conjunction with all other relevant design drawings.

c. O.S. data used for plans are printed under © Ordnance Survey Ireland Government of Ireland. All rights reserved. Licence Number 2021/OSI_NMA_180 National Transport Authority. All elevations are not used for any purpose without the prior permission of NTA. Transverse Mercator Grid (ITM) as defined by OSI active local GPS station.

d. Information concerning the position of apparatus shown on this drawing is based on drawings supplied by the utility owners and/or the utility works contractor, whilst every care has been taken in the preparation of this drawing, positions should be taken as approximate and are intended for general guidance only and no representation is made by the NTA as to the accuracy, completeness, sufficiency preparation of this drawing, positions should be taken as approximate and are intended for general guidance only and no representation is made by the NTA as to the accuracy, completeness, sufficiency or otherwise of this drawing and the position of the apparatus. The information contained herein does not purport to be comprehensive or final as the apparatus is subject to being altered and/or superseded. Recipients should not rely on this information. Any liabilities are hereby expressly disclaimed.

e. The information contained herein has been provided by the NTA but does not purport to be comprehensive or final. Recipients should not rely on the information. Neither the NTA nor any of its directors, officers, employees, agents, stakeholders or advisers make any representation or warranty as to, or accept any liability or responsibility in relation to, the adequacy, accuracy, reasonableness or completeness of the information provided as part of this document or any matter on which the information is based (including but not limited to loss or damage arising as a result of reliance by recipients on the information or any part of it). Any liabilities are hereby expressly disclaimed.



Rev	Date	Drn	Chk'd	App'd	Description
M01	27/01/2023	RG	JM	RS	ISSUE FOR PHASE 4: PLANNING

Client: **NTA**
Údarás Náisiúnta Iompair
National Transport Authority

Engineering Designer: **Jacobs**

Date: 27/01/2023
Scale: As indicated @ A1

Project Code: BCIDB
Originator Code: JAC

Drawn: RG
Checked: JM
Approved: RS

Programme Title: BUSCONNECTS DUBLIN CORE BUS CORRIDORS INFRASTRUCTURE WORKS			
Drawing Title: BRAY TO CITY CENTRE SCHEME ST LAURENCE SUBWAY WIDENING GENERAL ARRANGEMENT SHEET 2 OF 2			
Drawing File Name: BCIDB- JAC- STR_GA-0013_BR_00- DR- CB-0002	Sheet Number: 2 of 2	Status: A	Rev: M01

DO NOT SCALE USE FIGURED DIMENSIONS ONLY

Appendix B. **Specification for Investigations**

Contents

1.	Introduction	1
2.	Location	2
3.	Survey Requirements	3
4.	Intrusive Investigation	4
4.1	Excavation for Foundation Survey	4
4.1.1	Methodology	4
4.2	Existing Waterproofing	4
4.3	Reinstatement of Waterproofing	5
4.4	Equipment (envisaged but not limited to, Contractor to ensure appropriate equipment will be used)	5
4.5	Investigation report.....	5
4.6	Assessment of precast subway	5
4.6.1	Visual Inspection Survey	5
4.6.2	Delamination Survey of Surface Concrete	6
4.6.3	Covermeter Survey	6
4.6.4	Exposures and Breakouts	7
4.6.5	Core Sampling	8
4.6.6	Reinstatement/ Restoration	10
4.6.7	Investigation Report	10
5.	Laboratory Work	11
5.1	General.....	11
5.2	Compressive strength testing	11
6.	Health and Safety	12
7.	References	13

1. Introduction

Jacobs are undertaking the Engineering Design Services for the Planning Stage through to the end of the Statutory Process of the BusConnects Radial Core Bus Corridors Infrastructure Upgrade Programme (the Programme).

During the development of the preliminary design report, it has been identified the need for highway widening over the St Laurence Park Subway to accommodate the new proposed route.

To facilitate the new design, confirmation of existing structural details and an assessment of the existing structure is required.

Transport Infrastructure Ireland (TII) Regional Bridge Management are responsible for management of the existing structure. They should be consulted on any proposals for investigation and would act as Technical Approval Authority for assessments and designs relating to the structure. It should be noted that the structure is located within the boundaries of Dún Laoghaire-Rathdown County Council (DLRCC).

Prior to carrying out any site investigation works, Jacobs shall be informed of the anticipated start date and duration, so that TII Regional Bridge Management may also be notified.

Currently no as-built information for the structure is available, as such a full investigation is required.

The investigation shall include:

- A full dimensional survey;
- Investigation of existing waterproofing over deck
- Concrete Investigations
- Determination of reinforcement size, type, and arrangement
- Concrete conditional survey
- Core sampling
- Chloride content testing

2. Location

St Laurence Park Subway is located approximately 9km south of Dublin City Centre. It carries the N11 over a pedestrian link between St Laurence Park and Patrician Villas.

Table 2.1 Location & Description of St Laurence Park Subway

Identity	Irish OS Grid	ITM Grid	Description	Authority
St Laurence Park Subway	320295E 228157N	720235E 728182N	Existing subway beneath the N11 linking St Laurence Park and Patrician Villas. Composition is a box culvert with cantilever wing walls.	Dún Laoghaire-Rathdown County Council

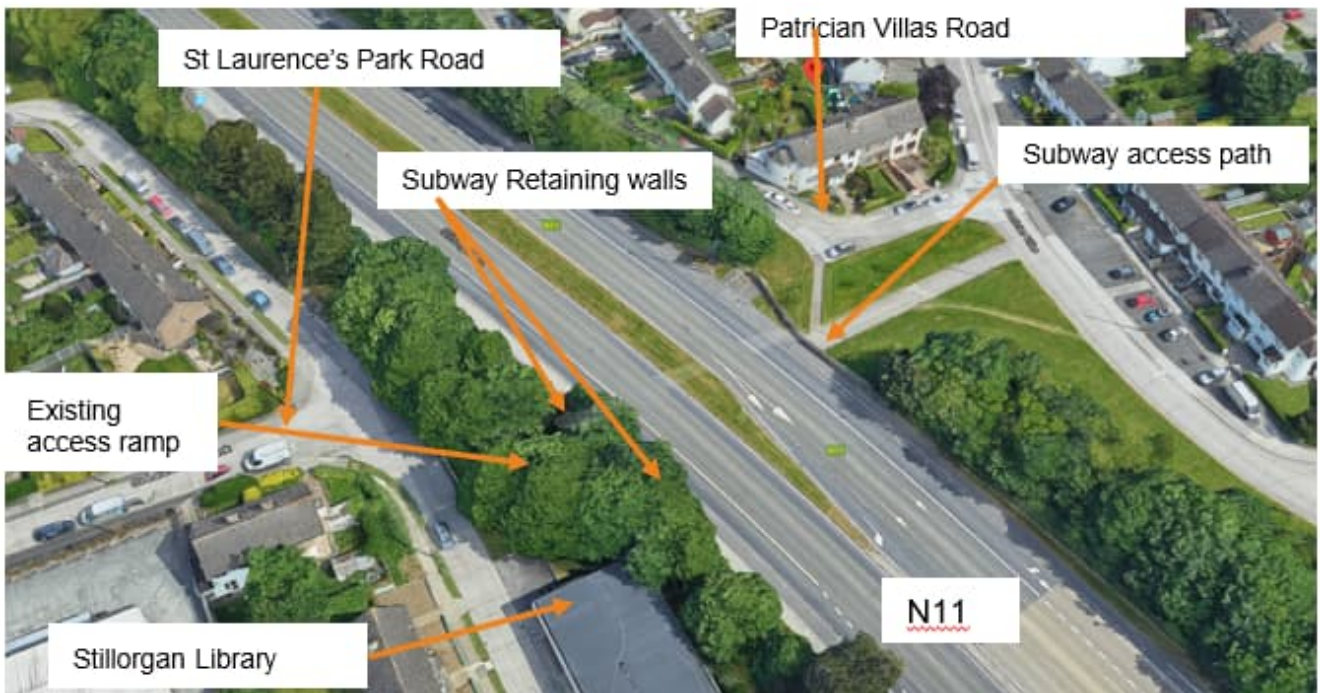

Figure 2.1 Location Plan

3. Survey Requirements

St Laurence Park Subway is assumed to be a box culvert with cantilever wing walls. A full dimensional survey will be completed to measure the key dimension of the structure as detailed in Table 3.1.

It should be possible to measure most of the structure without any intrusive works; however, some excavation will be required:

- Excavation required adjacent to a wing wall to measure the extent of the foundations.
- Excavation required to determine the width of the deck and the depth of the fill.
- Results of dimensional survey shall be provided on pdf drawings at 1:200 scale showing plan, elevation, and section of the existing structure.

Table 3.1 Dimensional survey

Structural Element		Dimension (mm)
Overall height of structure ¹		
Overall width of structure ^{2,3}		
Length of north abutment wall ⁴		
Length of south abutment wall ⁴		
Expansion joint		
Min headroom		
Clear span	Footpath level ³	
	Max ³	
Foundation	Depth	
	Width ³	
Deck Slab	Depth	
Base slab / Footings	Width ³	
	Depth	

1. The measurement shall be taken from the base of the foundation to the top of the deck slab.
2. The measurement shall be taken from the exterior of the abutment walls.
3. The measurement shall be taken square to the structure.
4. The measurement shall be taken from the inside face of the wing wall.

4. Intrusive Investigation

The following intrusive surveys should be undertaken to obtain the required information to inform preliminary design of the subway extension.

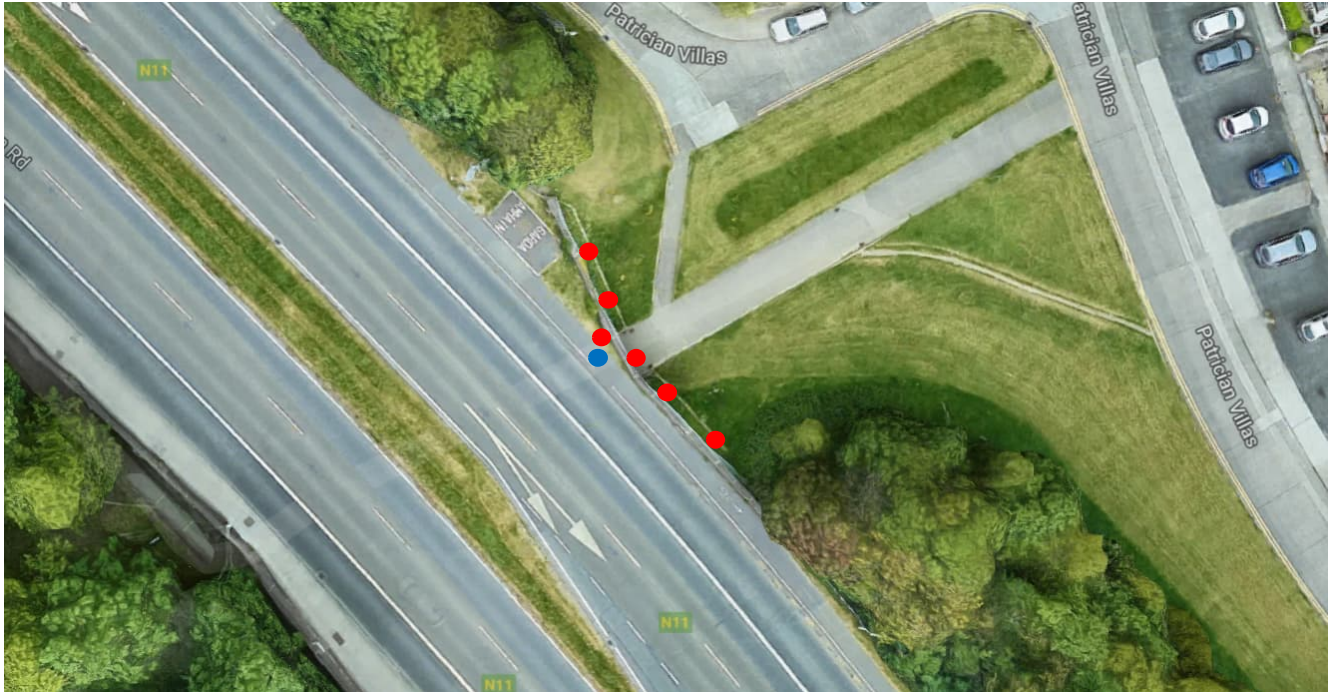

Figure 4.1: Locations of trial pits for investigation. Foundation and dimension survey indicated by red. Waterproofing indicated by blue

4.1 Excavation for Foundation Survey

Trial pits shall be undertaken at various locations at the east of the structure to confirm depth of foundations and geometry of the existing concrete box. Properties of the excavated material should be recorded to inform the layer reinstatement.

4.1.1 Methodology

1. Ensure traffic management has been set up as appropriate
2. Mark out areas for excavation,
3. Undertake CAT scan and locate existing services.
4. Photograph and measure excavated area.
5. Undertake excavation as appropriate [minimum 4 No. trial pits behind in front of east wingwalls, 1 No. trial pits at box base, 1 No. trial pits above existing concrete]
6. Measure fill depth to base of foundation and confirm thickness of walls and deck slab.
7. Confirm extent of foundation and measure foundation geometries as appropriate
8. Reinstatement excavated area as appropriate, trial pits above structure to be reinstated as per 4.3
9. Remove TM when appropriate

4.2 Existing Waterproofing

The details of existing waterproofing system to the deck are currently unknown. The waterproofing system is assumed to be a sheet membrane system eg. Servidek/Servipak or similar.

A 1500 x 1500mm area of hard verge shall be exposed. Within this a 1000 x 1000mm area of protection to waterproofing shall be removed and then a 700 x 700mm area of existing waterproof removed to allow for measurement of depth. Properties of the waterproofing layers shall be recorded to inform the layer reinstatement. Care shall be taken to avoid any damage to the underpass structure. This test panel shall be located such that the back of the abutment can be identified allowing for the thickness of the abutment to be recorded.

Pull-off/adhesion test should be undertaken on substrate to determine the suitability for receiving spray applied waterproofing.

Prior to reinstatement of the waterproofing and backfill a concrete conditional survey should be undertaken of the exposed deck.

4.3 Reinstatement of Waterproofing

Waterproofing shall be repaired with an approved product in accordance with Manufacturer's instructions. The waterproofing protection shall be reinstated with a like for like material and compacted on site to an adequate amount. The hard verge shall be repaired to match the existing construction.

The Contractor shall confirm their proposals for reinstatement of waterproofing and waterproofing protection for the acceptance of Jacobs and the Leinster Regional Bridge Management prior to commencement of reinstatement. A compatible, approved system with adequate overlaps shall be provided.

All trial holes shall be fully reinstated after completion of site investigation works.

Restatement of waterproofing shall not be undertaken until covermeter survey has been complete in accordance with Section 4.6.3.

4.4 Equipment (envisaged but not limited to, Contractor to ensure appropriate equipment will be used)

- Mini excavator
- Breaker
- Dumper
- General hand tools
- Machine for footway and embankment reinstatement
- Covermeter

4.5 Investigation report

The investigation report shall present the findings in a clear and concise manner with interpretation of the results against accepted criteria. The site results shall be tabulated and supported by diagrams and photographs where appropriate. All laboratory test certificates shall be included in an appendix along with a copy of their INAB accreditation schedule clearly identifying each test is listed.

4.6 Assessment of precast subway

4.6.1 Visual Inspection Survey

A comprehensive Visual Inspection Survey (VIS) of all exposed precast subway elements shall be undertaken.

The VIS shall be performed by a Civil/Structural Engineer with at least 5 years of experience in visual and condition assessment in similar field.

Locations of all observations shall be marked on scale drawings and described in the investigation report, along with supporting high-resolution photos, both from a distance to show location in relation to other elements and close-ups of findings showing scale, and (where necessary) additional sketches.

The VIS shall cover and include the following observations as a minimum:

- Cracks: location, extent (length), and range of measured widths, as well as any indication of depth.
- Spalling / incipient spalling, extent (length), and width, as well as any indication of depth.
- Damp Patches/ Water Leakage: signs of moisture (e.g. within internal voids, and soffit) and any signs of water leakages in any location.
- Efflorescence/ Leaching/ Salt Crystallization: deposition of white salts or limewater on the concrete surface.
- Rust Staining (corrosion of reinforcement or steel elements): brown or rust coloured stains, and rough dimensions of area where these are observed.
- Poor quality concrete: e.g. signs of honeycombing, voids, poor compaction etc.
- Any misaligned joints and deteriorated sealant materials, where present.
- Any visible deterioration of bearings, e.g. misalignment, fatigue, corrosion, etc.
- Evidence of historical accidental actions: e.g. fire, vehicle collision, etc.

Note: Additional testing may be needed at a later stage, should any indications be found that structural integrity and/ or durability may have been, or are at risk of being compromised. This could include both intrusive and non-intrusive techniques.

4.6.2 Delamination Survey of Surface Concrete

A delamination survey shall be completed to areas of interest, as identified during the VIS (cracking, spalling, rust staining etc.).

The tests shall be carried out in accordance with guidance given in ASTM D4580 'Measuring Delamination in Concrete Bridge Decks by Sounding' (Procedure B - using hammer tap in place of chain drag).

Identified delaminated areas shall be marked on scale drawings, including approximate dimensions, and described in the investigation report with supporting high-resolution photos, showing limits of areas temporarily drawn onto concrete.

4.6.3 Covermeter Survey

The bar size and spacing and the concrete cover depth to reinforcement shall be determined using an electromagnetic covermeter, Hilti Ferroskan (or similar approved), in accordance with BS 1881-204. This shall include at least 3 wall panels and 3 soffit panels.

The detection range of the covermeter used shall be sufficient for confidently surveying reinforcement details with cover depths of at least 100mm.

The covermeter survey shall be carried out on a 2000mm x 2000mm grid as directed in the agreed locations. The orientation of the covermeter scans shall be perpendicular to the expected direction of the reinforcement. Advantage should be taken of the excavation of the deck to determine the waterproofing and a covermeter survey of this location should be undertaken prior to reinstatement of waterproofing.

The equipment to be used shall be calibrated and have relevant certification.

The equipment to be used shall also be calibrated on site by breakouts of tested areas, by comparing values recorded by the covermeter versus the actual values determined by breakouts. Such calibrations may take place retrospectively, following the covermeter surveys. The details of this calibration shall be recorded and included in the Investigation Report.

The survey shall identify the minimum cover depths of reinforcement bars within the survey grid, separately for the main and the secondary reinforcement and the shear links, where applicable.

The report shall include the following as a minimum:

- Date and time of application (per location) and name(s) of user(s)
- The type of equipment and additional software used for analysis (where applicable), including input settings and certifications for laboratory calibration
- The site calibration details as outlined above, including a calibration curve (where applicable)
- A drawing or sketch showing the exact testing locations and orientation of the scan grid or linear scans, as well as the starting point of each scan, in relation to fixed points of the structure (e.g. slab corner)
- All recorded values and resulting bar sizes, spacing and cover depths, both before and after calibration (raw measurements and corrected values, based on calibration), indicating minimum cover depth for each reinforcement type (main, secondary, shear links), and additional notes made on site. In particular it should be recorded whether the deck slab transverse reinforcement is orthogonal or skew to the main reinforcement.
- All raw scan files in the standard software output format, properly named to be able to identify them against testing locations and orientation (where applicable)

4.6.4 Exposures and Breakouts

4.6.4.1 Breakouts (removal of concrete)

Breakouts shall be made at the at least 1 wall and 1 soffit location (following the completion of covermeter surveys) by a suitable method to be proposed by the Contractor and agreed with the Investigation Supervisor.

At bar locations the depth of the breakout shall be sufficient to expose the full diameter of the main bar parallel to the concrete surface, and should extend to a minimum distance of 20mm beyond the rear face of the bar.

The length and width shall be sufficient to expose at least 2 bars: 1 transverse and 1 longitudinal (indicative sizing for breakouts is 200mm x 200mm but this may need to be increased based on rebar spacing). Results from the covermeter survey should be used to locate an appropriate location to break out.

Care shall be taken to avoid damaging the reinforcement. A saw-cut 20mm deep shall mark the boundary of the breakout and the operative shall remove the concrete in such a manner as to avoid damaging the reinforcement. If the reinforcement be damaged, this shall be noted and recorded in the factual report, including commentary and photographs of the damaged area.

The exposed area shall be visually examined to identify and record the following as a minimum:

- the number and layout of exposed rebars
- the likely type of reinforcement and nature of fabrication
- the diameter of all exposed rebars, as an average of at least 3 independent measurements by calliper for each rebar type and orientation

- the condition of the rebars, with special focus on any signs of corrosion. Where corrosion products are evident, they shall be locally removed at the worst-affected location to allow for an estimate of the remaining uncorroded bar diameter (by calliper) and loss through corrosion to be estimated (as the difference in diameters between corroded and uncorroded bars of the same type)
- the actual depth of cover from the element surface to the nearest surface of each rebar group (main bars, secondary bars), as an average of at least 3 independent measurements

The investigation report shall include the following as a minimum:

- The equipment and method of breakout and its dimensions
- A drawing or sketch showing the breakout dimensions and locations, measured in relation to fixed points of the structure (e.g. slab corner)
- Annotated sketches to record all specified details of the reinforcement as above
- High resolution photographs that show the location of the breakout area in perspective of the surrounding area and close-up pictures focusing on the exposed rebars in the breakout area.

4.6.5 Core Sampling

Cores shall be extracted as per IS EN 12504-1.

Prior to coring, an electromagnetic covermeter shall be used to confirm the absence of embedded steel at the sample location in accordance with BS 1881-204.

Cores with minimum dimensions of 100mm (nominal diameter) x 200mm (length) shall be taken from identified locations. Shorter lengths may be acceptable subject to confirmation that the length to diameter ratio after preparation is suitable for compressive strength testing.

At least 3 no. cores (suitable for compressive strength testing) shall be taken from precast units. The core locations shall be at the 5 lowest Rebound Hammer test results. A maximum of 2 no. 100mm diameter cores shall be retrieved from the slab soffit at non-critical locations. The proposed number of cores is based on the number required in AM-STR-06010 for the worst credible strength for a location. Concrete reinstatement will be required for the reinstatement as per section 4.6.7.

After sampling, each core shall be indelibly marked with a unique sample reference number and indication of the direction of coring and photographed.

The core shall then be wrapped in at least three layers of cling film and placed within a polythene bag of at least 1000 gauge. The bag shall be indelibly marked with the sample reference number and sealed.

A sample certificate shall be prepared, and a copy of the certificate shall accompany the sample.

Testing of the sample and reporting requirements from laboratory testing are included in Section 5.2.

The investigation report shall include the following as a minimum:

- The equipment and method of coring, including nominal sizes;
- A confirmation for completion of an electromagnetic covermeter scan prior to coring and confirmation on whether reinforcement has been cut including location within the core
- Number of cores taken, their dimensions, and a short description of their condition

- Photographic record as indicated above.
- Copy of a sample certificate as indicated above.
- All aspects as required in IS EN 12504-1 for test reporting

4.6.6 Chloride Content Testing

Chloride content sampling shall be carried out at a minimum of 4 locations including but not limited to the waterproofing test area, a soffit, a wall, and a floor; however test areas may be adjusted based on the findings of the visual inspection survey. The actual testing areas shall be recorded and their coordinates reported in relation to a clearly defined origin.

Chloride testing shall be undertaken in general accordance with the methods given in BRE IP 21/86 and Concrete Society Technical Report 32, by drilling a 25mm diameter hole at each test location, up to the specified maximum depth.

The first 5mm shall be discarded as unrepresentative. The depth increments as detailed below shall be used to collect samples.

- 5-20mm
- 20-35mm
- 35-50mm
- 50-65mm
- 65-80mm

The dust shall be collected and individually bagged for each of the depth increments.

A sufficient quantity of each dust sample shall be collected to allow for chemical analysis.

4.6.6.1 Methodology

The following methodology for drilled dust sampling shall be used:

- i. Confirm the absence of embedded steel using an electromagnetic covermeter;
- ii. Mark the location using chalk, crayon or marker pen;
- iii. Drill dust samples using a 25mm diameter drill bit (more holes are needed for smaller diameter holes in order to obtain a sufficient and representative sample);
- iv. Collect the dust from the holes for each of the depth increments (discard the outer 5mm);
- v. Blow out all traces of dust between each depth increment using blow out pump or compressed air;
- vi. Clean the sample collector between increments;
- vii. Retain the dust samples in sealed, marked sample bags.

The following methodology for core sampling shall be used:

- viii. Confirm the absence of embedded steel using an electromagnetic covermeter;
- ix. Mark the location using chalk, crayon or marker pen;
- x. Extract core with 50mm diameter up to the specified maximum depth;
- xi. Surface dry the core with cloth or paper towel;
- xii. Wrap the core sample in clingfilm and place in a sealed container (e.g. polyethene bag and core box).

The following equipment shall be used:

- xiii. Electrical percussion drill (110V) + drill bits;
- xiv. Generator or Transformer/rectifier + leads + appropriate connectors;

- xv. Sample tube;
- xvi. Sealable sample bags ;
- xvii. Steel rule or depth gauge;
- xviii. Bottle brush to clean out sample tube;
- xix. Blow out pump;
- xx. Chalk, crayon or marker pen.

4.6.7 Reinstatement/ Restoration

4.6.7.1 Concrete repairs

All concrete breakout areas including core holes shall be reinstated in accordance with CC-SPW 05500. All repairs are to be cured adequately and any deck surface repairs shall be allowed sufficient time to set prior to the reinstatement of fill materials

All concrete, including core holes and breakouts, shall be reinstated with a BBA certified proprietary polymer modified cementitious repair material complying to Principle 3/ Method 3.2 of IS EN 1504-3, Class R4.

Repair work shall be in accordance with IS EN 1504-10, including Quality Control to IS EN 1504-8.

Repair work shall be undertaken on the same day, immediately after the completion of the calibration and survey work of the breakouts or coring.

The Contractor shall propose a repair product and method statement to IS EN 1504 for approval by the Investigation Supervisor.

The repair material shall be used in strict accordance with the manufacturer's recommendations and requirements in IS EN 1504, whichever are more onerous.

4.6.8 Investigation Report

The investigation report shall include the following as a minimum:

- Methods for reinstatement/ restoration of exposed/breakout areas and core holes.
- Data sheets of materials including declaration of performance certificates and certificate of conformance/CE marking.
- Records of any problems encountered on site

A digital copy of this report shall be provided and forwarded to Leinster Regional Bridge Management for their records.

5. Laboratory Work

5.1 General

The laboratory work shall be undertaken by a UKAS/INAB accredited or equivalent approved laboratory.

The Contractor shall submit their chosen laboratory with supporting documentation for approval by the Investigation Supervisor.

5.2 Compressive strength testing

Core samples shall be subjected to visual examination prior to testing for strength and density in accordance with IS EN 12504-1 and IS EN 12390-7.

Test results shall be presented in tabular format within the laboratory test report.

The investigation report shall include the following as a minimum:

- A summary table of estimated strength and density for each, uniquely identified, core
- Estimate maximum size of the aggregate
- Visual inspection noting any abnormalities
- A copy of the laboratory test report
- Copies of all laboratory test certificates
- All aspects as required in IS EN 12504-1 and IS EN 12390-7 for test reporting

6. Health and Safety

The Contractor shall undertake the following as a minimum to reduce the health and safety risk associated with the works. Any hand-held excavations to be undertaken in accordance with the Health and Safety Authority Code of Practice For Avoiding Danger From Underground Services guidelines.

The existing waterproofing system may potentially have asbestos due to the age of the structure. The Contractor shall undertake an asbestos survey, using appropriately qualified staff, to confirm if asbestos is present prior to any intrusive works to existing waterproofing.

The Contractor shall confirm the proposals for their asbestos survey for the acceptance of Jacobs and the Highway Authority prior to the commencement of works.

In the event that asbestos is found to be present the scope of further work should be agreed with Jacobs and the Highway Authority.

The actions listed below are considered appropriate minimum measures for Health and Safety. The Contractor should review the Designer's risk assessment and plan an appropriate safe method of work.

- Set up appropriate exclusion zones and traffic management as needed for the safe undertaking of the survey. Contractor to retain a minimum of 1.2m clear width for the subway, with the works safely isolated from the public. A banksman shall be provided to manage the pedestrian movements as appropriate and escort members of the public through the site where necessary. Details of these shall be submitted to the Designer for review.
- Undertake CAT scans prior to breaking out/excavating as part of a 'permit to break ground' system.
- Monitor the use of vibrating tools in line with current industry best practice.
- Reduce the risks of falling from height.
- Reduce the risks of manual handling by limiting loads (as far as practical) carried to 20kg.
- Use tools with built in dust suppression.
- Ensure that excavations are made safe.

A Designer's Risk Assessment has been completed for this investigation and detailed in Appendix A.

7. References

ASTM D4580 Standard Practice for Measuring Delaminations in Concrete Bridge Decks by Sounding

BS 1881-204 Testing concrete. Recommendations on the use of electromagnetic covermeters

CS 455 The assessment of concrete highway bridges and structures

IS EN 1504-3 Products and systems for the protection and repair of concrete structures - Definitions, requirements, quality control and evaluation of conformity. Structural and non-structural repair

IS EN 12504-1 Testing concrete in structures. Cored specimens. Taking, examining, and testing in compression

IS EN 12504-2 Testing concrete in structures. Non-destructive testing. Determination of rebound number

Appendix A. **Designer's Risk Assessment**

DESIGN HAZARD ELIMINATION AND RISK REDUCTION REGISTER (ROI)

Latest Review Date	
Phase	
C Construction	
M Maintain / Clean	
U Use as Workplace	
D Demolish	
Project Name:	Upgrade Programme –St Laurence Subway
Project Number:	32110901
Design Package:	St Laurence Structural Investigations
Client:	National Transport Authority

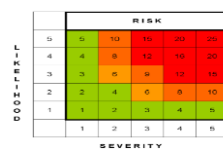
Probability	Worst Potential Severity (WPS) of Impact	Risk Rating
<p>1: Highly Unlikely</p> <p>2: Unlikely</p> <p>3: Possible</p> <p>4: Likely</p> <p>5: Highly Likely</p>	<p>1: Nil or slight injury / illness, property damage or environmental issue.</p> <p>2: Minor injury / illness, property damage or environmental issue.</p> <p>3: Moderate injury or illness, property damage or environmental issue.</p> <p>4: Major injury or illness, property damage or environmental issue.</p> <p>5: Fatal or long term disabling injury or illness. Significant property damage or environmental issue.</p> <p>10. Multiple fatalities and catastrophic event</p>	<p>NOTE: The purpose of Risk Rating is to determine which risks are significant. It is a subjective assessment and not an absolute or precise determination</p> 

1	2	3	4	5	6	7	8	9	10	11	12	13	14	15	16	17	18	19	20	21	22	23	24	25
Risk ID.	Formal Review Description	Phase	Particular or Non-Particular Risk (if applicable)	Activity	Potential Hazard	Person(s) Most at Risk	Prob	WPS	Initial Risk Rating	Discipline	Design Measures to Eliminate Hazards	Design Measures to Reduce Risk	Residual Prob	Residual WPS	Residual Risk Rating	Residual Risk Description	Included on Drawing No(s) or other doc. (give ref.)	Action By (Name or Role)	Target Date	Revised Target Date	Date Action Complete	Tracker Status	Comments	Primary Legislation
1	5: Design Stage Review	C	Not Applicable	Excavation of trial pits	Hitting Embedded services	Construction	3	5	15	Civil / Structural	None - Works required	Available information on existing utilities to be made available prior to excavation.	1	5	5	Risk obvious to a competent contractor. CAT survey to be undertaken before excavation	N/A	Contractor	TBC	TBC	TBC	Open	No further comments.	2013 Const Regs (PSDP)
2	5: Design Stage Review	C	13. Interaction with traffic	Works near the highway	Vehicle-Vehicle or Vehicle-Pedestrian collision	Construction	3	4	12	Civil / Structural	Select trial pit locations away from highway	Exclusion zones and traffic management	1	3	3	Risk obvious to a competent contractor. Appropriate safe method of work to include consideration of risk	N/A	Contractor	TBC	TBC	TBC	Open	No further comments.	2013 Const Regs (PSDP)
3	5: Design Stage Review	C	Not Applicable	Breaking and cutting of surfacing materials	Inhalation of silica and other dust pollution.	Construction	3	3	9	Civil / Structural	None - Works required	Area of excavation limited to that required.	1	3	3	Risk obvious to a competent contractor. Appropriate safe method of work to include consideration of risk	N/A	Contractor	TBC	TBC	TBC	Open	No further comments.	2013 Const Regs (PSDP)
5	5: Design Stage Review	C	1. Falling from height	Investigation of the subway deck	Injury or death from falls	Construction	1	5	5	Civil / Structural	Select areas of investigations away from potential unprotected drops.	Existing edge protection adequate	1	5	5	Risk obvious to a competent contractor. Appropriate safe method of work to include consideration of risk	N/A	Contractor	TBC	TBC	TBC	Open	No further comments.	2013 Const Regs (PSDP)
6	5: Design Stage Review	C	20. Interaction with the public	Incurion into works area	Injury to member of public in works area	Public	2	4	8	Civil / Structural	Works area to be clearly defined	Area of excavation limited to that required.	1	4	4	Risk obvious to a competent contractor. Appropriate safe method of work to include consideration of risk	N/A	Contractor	TBC	TBC	TBC	Open	No further comments.	2013 Const Regs (PSDP)
7	5: Design Stage Review	C	4. Chemical or biological substances	General Works	Exposure to needles and other drug paraphernalia	Construction	1	4	4	Civil / Structural	None - Works required	Potential risk communicated to contractor	1	4	4	Risk obvious to a competent contractor. Appropriate safe method of work to include consideration of risk	N/A	Contractor	TBC	TBC	TBC	Open	No further comments.	2013 Const Regs (PSDP)
8	5: Design Stage Review	C	Not Applicable	Use of percussion tools	Hand Arm Vibration Syndrome (HAVS) aka vibration white finger	Construction	4	3	12	Civil / Structural	None - Works required	Area of excavation limited to that required.	1	3	3	Risk obvious to a competent contractor. Appropriate safe method of work to include consideration of risk	N/A	Contractor	TBC	TBC	TBC	Open	No further comments.	2013 Const Regs (PSDP)
9	5: Design Stage Review	C	4. Chemical or biological substances	General Works	Possible exposure to asbestos containing materials.	Construction	3	5	15	Civil / Structural	None - Works required	Asbestos survey of the waterproofing has been specified to identify if they are asbestos containing materials. The RAMS and scope will need to be updated following the completion of the assessment	1	5	5	Risk obvious to a competent contractor. Appropriate safe method of work to include consideration of risk	N/A	Contractor	TBC	TBC	TBC	Open	No further comments.	2013 Const Regs (PSDP)
10	5: Design Stage Review	C	2. Burial under earthfalls	Collapse of earthworks	Injury or death from collapsed excavation, partial structural collapse	Construction	2	5	10	Civil / Structural	None - Works required	Area of excavation and depth of excavation limited to that required.	2	5	10	Risk obvious to a competent contractor. Appropriate safe method of work to include consideration of risk	N/A	Contractor	TBC	TBC	TBC	Open	No further comments.	2013 Const Regs (PSDP)

Appendix B. Plan of Existing Utilities

Figure A.1: Plan View of Existing Utilities overlaying OS Map

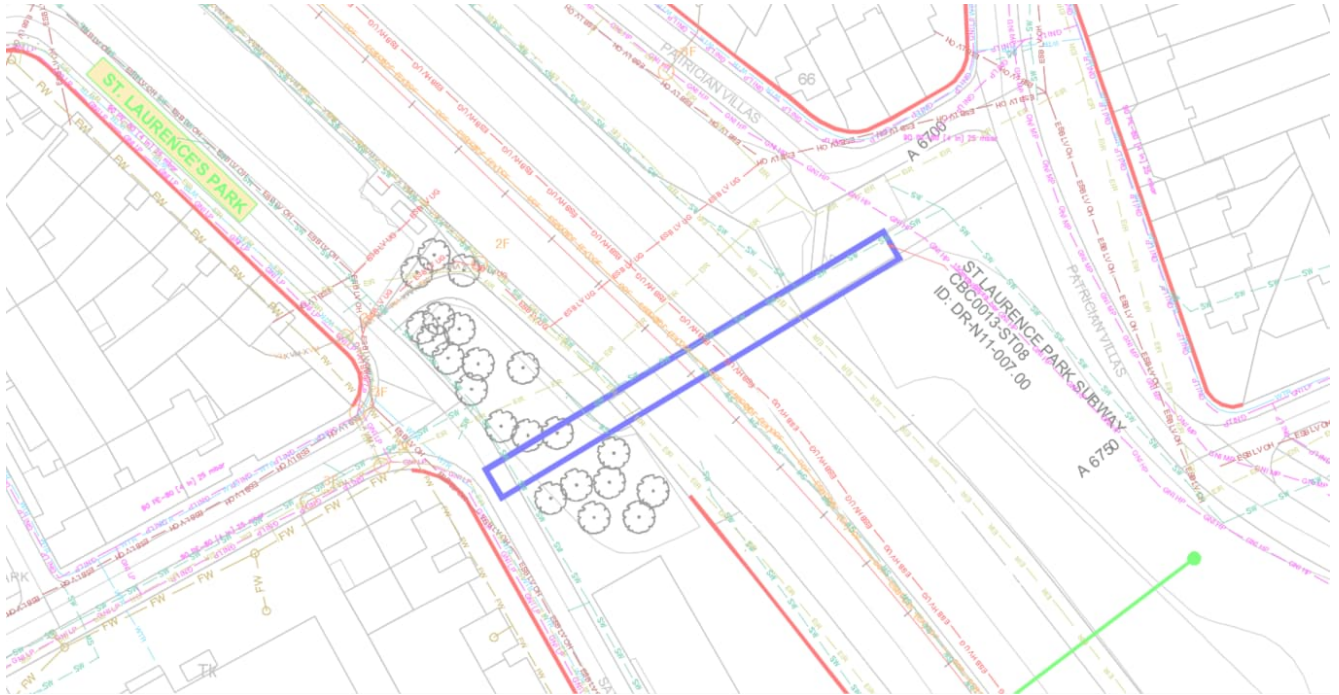

* Further Information can be provided upon request



Appendix F3
Loughlinstown Roundabout
Preliminary Design Report

© Copyright 2023 Jacobs Engineering Ireland Limited. The concepts and information contained in this document are the property of Jacobs. Use or copying of this document in whole or in part without the written permission of Jacobs constitutes an infringement of copyright.

Limitation: This document has been prepared on behalf of, and for the exclusive use of Jacobs' client, and is subject to, and issued in accordance with, the provisions of the contract between Jacobs and the client. Jacobs accepts no liability or responsibility whatsoever for, or in respect of, any use of, or reliance upon, this document by any third party.

**Preliminary Design Report-
Consultation**

STA-1b

Categories 1, 2 & 3

Scheme Name

Name and Location – BusConnects Route 13 Bray to City Centre, Dublin

Structure(s)

Name and nature of the Structure(s) – Loughlinstown Roundabout Retaining Wall

Structures Options Report

Reference - R13-RW043

Revision - M01

Date - 27th January 2023

Submitted by

Signed  _____

Name John McElhinney

Position Structural Discipline Lead (Team Leader)

Organisation Jacobs Engineering

Date 27/01/2023

Structures Section confirmation of consultation

Signed _____

Name _____

Position _____

Date _____

* This application should appear as the first page after the cover of the Preliminary Design Report.

Contents

1.	Introduction.....	1
1.1	Brief.....	1
1.2	Background.....	1
1.3	Previous Studies.....	2
2.	Site & Function.....	3
2.1	Site Location.....	3
2.2	Function of Site and Obstacles Crossed.....	3
2.3	Choice of location.....	3
2.4	Site Description and Topography.....	4
2.5	Vertical and Horizontal Alignments.....	4
2.6	Cross Sectional Dimensions.....	5
2.7	Existing Underground and Overground Services.....	6
2.8	Geotechnical Summary.....	6
2.9	Hydrology and Hydraulic Summary.....	7
2.10	Archaeological Summary.....	7
2.11	Environmental Summary.....	7
3.	Structure & Aesthetics.....	8
3.1	General Description of Recommended Structure and Design Working Life.....	8
3.2	Aesthetic Considerations.....	8
3.3	Proposals for the Recommended Structure.....	9
3.3.1	Proposed Category.....	9
3.3.2	Span Arrangement.....	9
3.3.3	Minimum Headroom Provided.....	9
3.3.4	Approaches including run-on arrangements.....	9
3.3.5	Foundation Type.....	9
3.3.6	Substructure.....	9
3.3.7	Superstructure.....	9
3.3.8	Articulation Arrangement.....	9
3.3.9	Vehicle Restraint System.....	9
3.3.10	Drainage.....	9
3.3.11	Durability.....	9
3.3.12	Sustainability.....	10
3.3.13	Inspection and Maintenance.....	10
4.	Safety.....	11
4.1	Traffic Management during construction.....	11
4.2	Safety during construction.....	11
4.3	Safety in use.....	11
4.4	Lighting.....	11
5.	Design Assessment Criteria.....	12
5.1	Actions.....	12

5.1.1	Permanent Actions.....	12
5.1.2	Snow, Wind and Thermal Actions.....	12
5.1.3	Actions Relating to Normal Traffic	12
5.1.4	Actions Relating to Abnormal Traffic.....	12
5.1.5	Footway or Footbridge Live Loading.....	12
5.1.6	Provision for Exceptional Abnormal Loads.....	12
5.1.7	Accidental Actions.....	12
5.1.8	Actions during Constructions.....	12
5.1.9	Any Special Loading not Covered Above.....	12
5.2	Authorities consulted and any special conditions required.....	12
5.3	Proposed Departures from Standards	13
5.4	Proposed methods of dealing with aspects not covered in standards.....	13
6.	Ground Conditions.....	14
6.1	Geotechnical Classification	14
6.2	Ground Conditions	14
7.	Drawings and Documents	16
7.1	List of All Documents Accompanying the Submission.....	16

1. Introduction

1.1 Brief

Jacobs have been appointed by the National Transport Authority (NTA) to undertake the Engineering Design Services for the Planning Stage through to the end of the Statutory Process of the BusConnects Radial Core Bus Corridors Infrastructure Upgrade Programme (the Programme). The Project has been split into four packages with Jacobs undertaking Package B.

This report outlines the Preliminary Design for the Loughlinstown Roundabout Retaining Wall (wall reference: R13-RW043) at the M11 & N11 roundabout on the CBC 13 Bray to City Centre route.

1.2 Background

The National Transport Authority (NTA) published the Transport Strategy for the Greater Dublin Area, 2016 – 2035 at the beginning of 2016. The strategy identifies a “Core Bus Network”, representing the most important bus routes within the Greater Dublin area, generally characterised by high passenger volumes, frequent services, and significant trip attractors along the routes. The identified core network comprises sixteen radial bus corridors, three orbital bus corridors and six regional bus corridors.

The Strategy states that it is intended to provide continuous bus priority, as far as is practicable, along the core bus routes. This will result in a more efficient and reliable bus service with lower journey times, increasing the attractiveness of public transport in these areas and facilitating a shift to more sustainable modes of transport. The Bray to City Centre Core Bus Corridor is identified as part of the Core Bus Network.

In March 2018, BusConnects Dublin was launched as part of major investment programme, including Metrolink and the Dublin Area Rapid Transport (DART) Expansion Programme, to improve public transport in Dublin, as part of the National Development Plan 2018-2027. The Bray to City Centre CBC serves the area to the south of Dublin city, creating an improved public transportation link for areas along the corridor.



Figure 1.1: BusConnects Dublin Radial CBC Network

1.3 Previous Studies

The first non-statutory public consultation on the BusConnects CBCs took place on a phased basis between November 2018 and May 2019. The second round of public consultations occurred between March 2020 and April 2020. A third round of public consultations then followed between November 2020 and December 2020.

Consultation with the principal project stakeholders (i.e. Dublic City Council, Transport Infrastructure Ireland, Utility companies and the National Transport Authority) has also taken place.

A desktop study was undertaken to identify the existing structures within the project extents, with site inspections undertaken where information was limited.

2. Site & Function

2.1 Site Location

The Loughlinstown Roundabout Retaining Wall is located approximately 15 km south of Dublin City Centre (ITM Grid Reference: 724924E, 722869N)

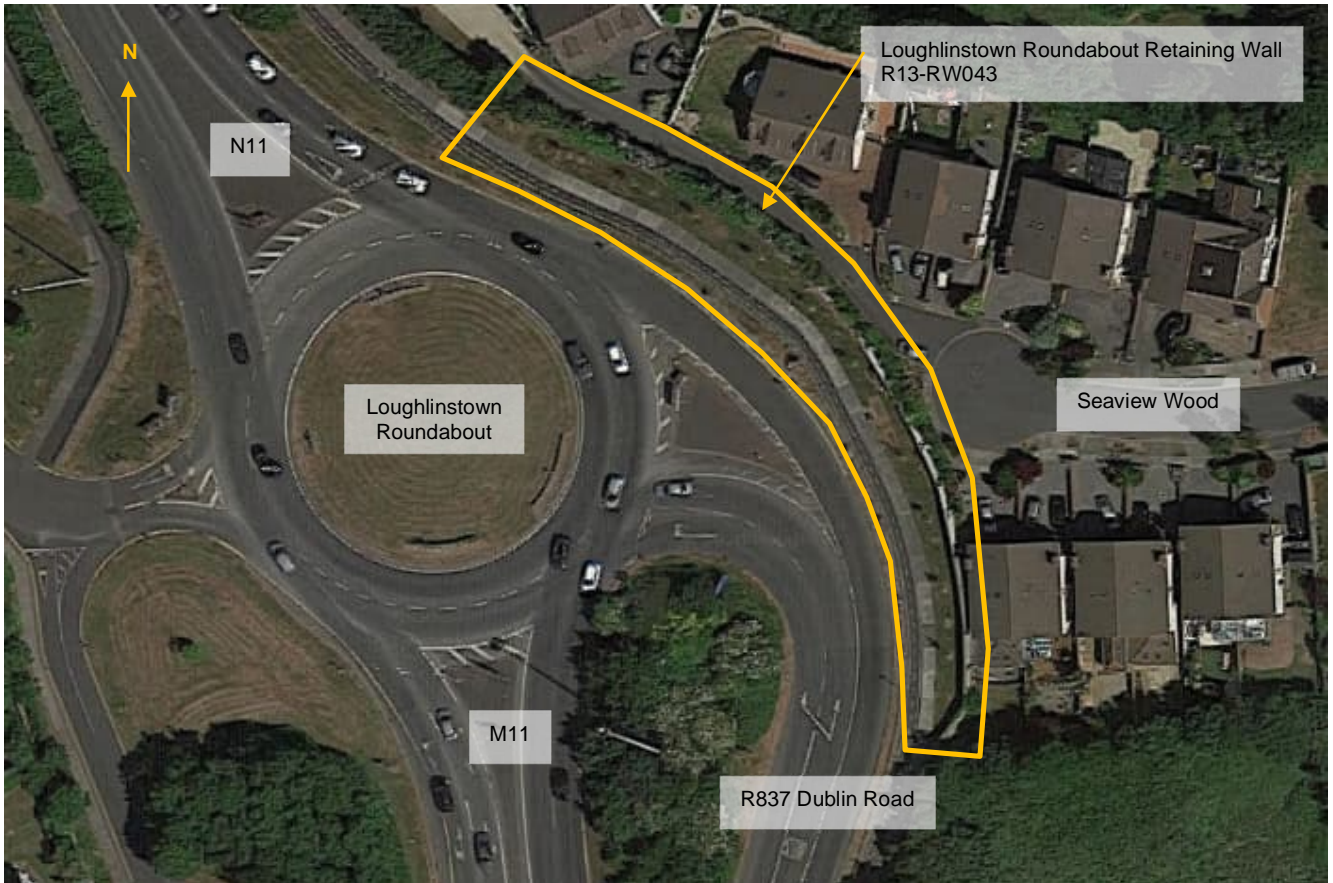

Figure 2.1: Plan view of Loughlinstown Roundabout Retaining Wall and surrounding features

2.2 Function of Site and Obstacles Crossed

The Loughlinstown Roundabout Retaining Wall retains the M11 & N11 roundabout with the R837 Dublin Road at its eastern end, and southbound lane of the R837 with a pedestrian footpath and dedicated two-way cycle lane. Seaview Wood, a residential street lies immediately to the east and north of the structure at an elevation up to a maximum of 4 m below the roundabout. The wall is curved in plan and measures approximately 110 m in length with a varying retained height, typically 3.6 m but as low as 2 m at the northern end. The structure and roundabout are located entirely within the boundaries of Dún Laoghaire-Rathdown County Council (DLRCC).

2.3 Choice of location

The location of works is determined by the site location and features described above. R13-RW043 will constitute works in the same location as the existing structure.

2.4 Site Description and Topography

Immediately behind the wall there is a grass verge of varying width that accommodates several service distribution boxes and newly planted trees. A footway and cycleway are located next to the verge. A small median is provided between the cycleway and the face of the traffic with a pedestrian safety barrier providing separation. The face of traffic typically runs approximately 10 m away from the wall.

Residential properties are in close proximity to the front of the wall on the Seaview Wood side. The southern section of the wall is the most constrained section with only an approximate separation of 1.4m from a residential property to the front face of the main wall. At the northern end of the wall access to 5 No. residential properties (Numbers 5-9 Seaview Wood) is provided immediately adjacent to the front face of the wall. This road provides the only access to these properties and must be maintained during any proposed works. Given the constrained space in front of the wall construction activities should be avoided on Seaview Wood where practical.



Figure 2.2: View of R13-RW043 from R837 Dublin Road



Figure 2.3: View of R13-RW043 from Seaview Wood

2.5 Vertical and Horizontal Alignments

Currently, there is a grass verge of 4.5 m typical width bordered by a footpath and dedicated cycle path. An additional green verge strip of 2.0 m typical width separates the highway from the cycle path with a galvanized steel railing running along its entire length.

The highway proposals at this location require the accommodation of a new bus lane, improved cycleway and footways. Consequently, the highway alignment will be realigned towards the wall, with the new kerblines positioned a maximum of 4 m from the existing kerblines. The existing verge beside the wall will either be

narrowed or removed completely to accommodate the alignment. Figure 2.4 and Figure 2.5 below illustrate the existing and proposed changes.

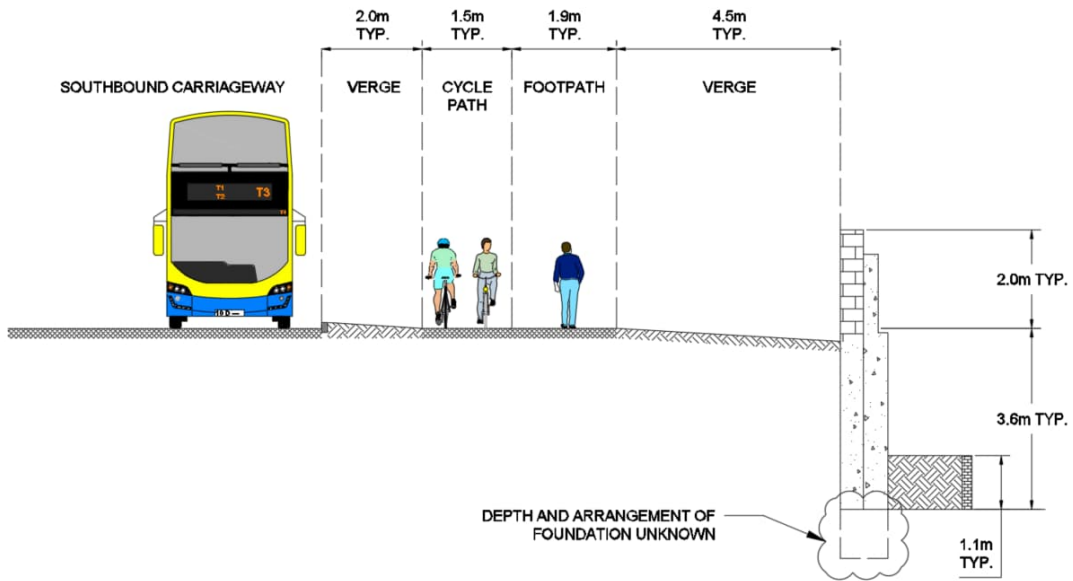

Figure 2.4: Typical existing cross section of highway alignment

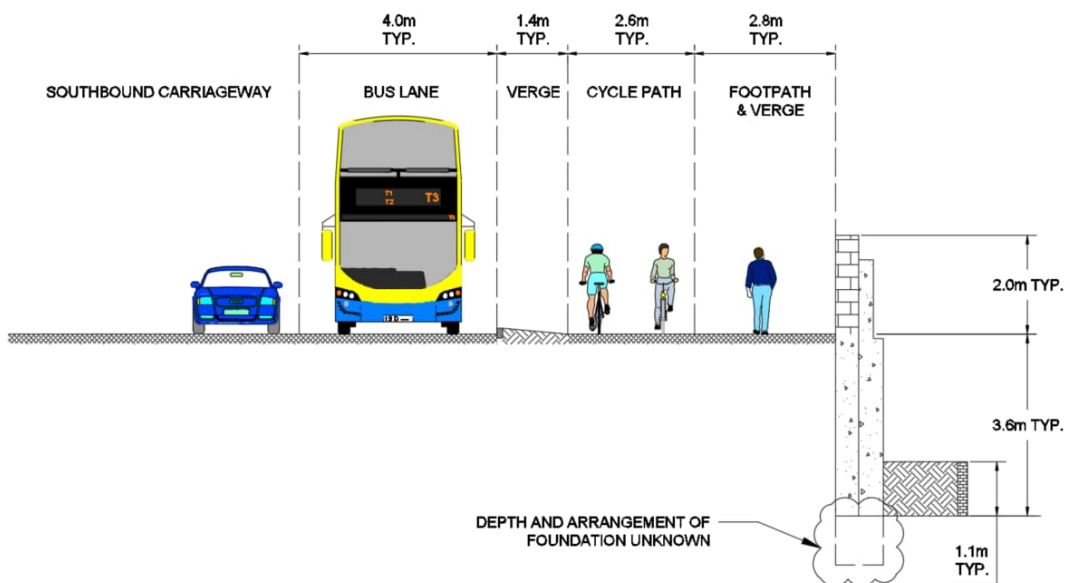

Figure 2.5: Typical proposed cross section of highway alignment

2.6 Cross Sectional Dimensions

Refer to drawing BCIDB-JAC-STR_GA-0013_RW_00-DR-CB-1111 in Appendix A – Drawings for the cross-sectional dimensions of Loughlinstown Roundabout.

2.7 Existing Underground and Overground Services

The following analysis is based on the utility records provided by their respective providers. There are several existing utility assets, located behind the existing retaining wall, beneath areas of proposed excavation works. Utilities in front of the wall on the Seaview Wood side have not been considered because the proposals outlined in this report do not involve excavation works on the front face of the wall.

No overhead utilities were found in the vicinity of the existing retaining wall.

There are several utilities in the zone between the back of the existing kerb line and the rear face of the retaining wall. The utility records and surface features indicate that the utilities in this area were generally installed to follow the curvature of the road alignment as it sweeps around the existing roundabout. These utilities include a 150 mm water main, 16no. Eir ducts, chambers and cabinets, a 125 mm low pressure gas main, low voltage ESB cabling, Virgin Media ducting and chambers. Records also indicate a medium voltage ESB cable crossing the road at the southern roundabout approach before traversing the existing retaining wall and entering Seaview Wood. The records and surface features indicate that the utilities involved are largely outside the footprint of the proposed bus lane widening, resulting in the utilities being located beneath the proposed cycle lane, footway and grass verge if left in-situ.

In addition, the existing road drainage network includes a storm water pipe which originates from the existing cycle lane at the northern end of the intersection and transects the proposed bus lane to the roundabout island.

A schedule of identified clashes can be seen in Table 2.1.

Underground Services	Overground Services
<p><u>ESB (Electricity)</u> Underground medium voltage ESB crossing the road and existing retaining wall into Seaview Wood. Underground low voltage ESB in verge along existing wall.</p> <p><u>Irish Water</u> 150 mm DIA water mains asset in the verge around the roundabout.</p> <p><u>GNI (Gas)</u> 125 mm GNI low pressure gas asset in the verge around the roundabout.</p> <p><u>Telecommunications (Eir & Virgin Media)</u> Eir ducts, chambers and cabinets beneath the existing footway/verge. Virgin Media ducting and chambers beneath the existing footway/verge.</p>	<p>None Identified</p>

Table 2.1: Summary of existing utilities

2.8 Geotechnical Summary

A geotechnical desktop study of the area has been undertaken using publicly available information and Ground Investigation reports available through the Geological Survey of Ireland.

Refer to Section 7 for details of the ground conditions at each retaining wall location.

2.9 Hydrology and Hydraulic Summary

It is not expected that the construction of the proposed works will have any significant impact on the local hydrogeology.

2.10 Archaeological Summary

There are no recorded areas of significant archaeological importance in the vicinity of R13-RW043.

2.11 Environmental Summary

Trees lie in front of the wall at the northern and southern ends and vegetation lies along the wall along Seaview Wood. Newly planted trees are spaced at regular intervals behind the wall which will be removed as part of the highway alignment proposals. Flowerboxes positioned on the existing railing and the ornamental Shankill road sign would be repositioned as per highway alignment proposals.

Aside from the impacts on the trees it is not considered that the proposed option will have a significant impact on any other aspects of the environment. There are no water courses or ecologically designated sites near the structure. It is not anticipated that soil on site has been exposed to contamination.

An Environmental Impact Assessment (EIA) Scoping Report is currently being produced, which will set out in greater detail the baseline, data collection requirements and methodologies to be used to assess each route.

During construction the adverse environmental impacts that may occur, include:

- Construction noise and vibration;
- Generation of dust;
- Vegetation removal;
- Deposition of mud on roads;
- Accidental spillage of fuels, oil or other materials;
- Clashes with Utilities;
- Potential for contaminated land in excavations (oil filled cables),
- Visual intrusion;
- Damage to Ecology
- Damage to cultural heritage features.

These may be controlled and minimised through good site practice and dedicated environmental management. The new structure will be constructed in accordance with the latest standards and recommendations for durability to maximise service life and reduce long-term maintenance requirements.

Concrete elements shall use cement replacement materials, such as ground granulated blast-furnace slag, to reduce the associated carbon footprint. At the end of its service life the concrete elements can be recycled through use as an aggregate replacement or used as engineering fill.

Arisings from structures demolition, which are not to be reinstated, shall be transported to a suitable processing area. Materials can be segregated into those that can be recycled, those which may be disposed of on site and those that can be disposed of off site as controlled waste or special waste.

Consultation with the appropriate local authority environmental health departments will be required to agree limits for noise and vibration. Where noise levels cannot be controlled at source the use of enclosures and barriers should be considered. Demolition methods will be chosen to minimise dust generation.

3. Structure & Aesthetics

3.1 General Description of Recommended Structure and Design Working Life

Four main options were considered in the options report to accommodate the widened highway cross section and bus lane provision at the R13-RW043. The preferred option is Ground Improvement Works, due to the relatively limited technical implications, relatively low geotechnical impacts, and lowest economical and construction impact out of the intrusive options.

This option would act as a load alleviating measure by locally improving the ground conditions directly below the surcharged traffic area increasing the angle at which the load can be distributed through the ground. The depth of ground improvement would be governed by the distance to the wall and the depth of the foundations which would have to be confirmed in detail design. The ground improvement would consist of layers of 6I/6J fill typically 300 mm to 500 mm thick compacted into cells confined by a proprietary geotextile system. Engineered granular soil, such as 6N fill, with a high friction angle can be laid to further reduce loading on the wall.

This solution only requires works behind the wall therefore there is no direct impact to residents on Seaview Wood. Out of the invasive proposals presented in the options report, this is the most sustainable option due to the lack of new concrete structures being built and retention of the existing wall. Excavation works would extend below the typical buried depths for most services and therefore any potential clashes would need to be identified, located, and ideally diverted out of the area undergoing ground improvement. The nature of the new works requires very little maintenance, with geotextile material having an expected design life of 100 years, however, it is recommended to conduct regular inspections on the existing wall in line with standard asset management procedures.

Disruption to the highway is expected from the excavation work, with closure of the outer lane of the roundabout and southbound R837 Dublin Road, to accommodate construction activities. As a result, appropriate traffic management measures would need to be put in place. Pedestrian and cycle routes would run alongside the works via a temporary walkway.

3.2 Aesthetic Considerations

R13-RW043 has a low visual significance in the area, where much of the exposed structure is visible from the Seaview Wood side. Here the assumed king post design with concrete buttresses is most prevalent, with a pebbledash render on the top half of the wall. An unrendered masonry wall can be seen on the far southern end of the wall. The parapet wall is the only feature visible from Loughlinstown Roundabout. The existing render is in poor condition with large sections of the wall showing exposed masonry or concrete. For the proposed option the mature vegetation located along the front of the wall on Seaview Woods shall be retained.

The present option is a buried solution which will not be visible to the public. The existing wall will remain in place and the existing appearance retained. Vegetation found to climb up and root itself into the wall and parapet should be cleared every 2 years as part of routine wall maintenance however small shrubbery on Seaview Wood can remain to enhance the visual aesthetic of the street.

Landscaping on the proposed verge should be updated to reflect the new highway alignment and maintained regularly.

3.3 Proposals for the Recommended Structure

3.3.1 Proposed Category

The retained height is smaller than 5m, hence the wall is classified as Category 1 structure in accordance with DN-STR-03001.

3.3.2 Span Arrangement

Not applicable.

3.3.3 Minimum Headroom Provided

Not applicable.

3.3.4 Approaches including run-on arrangements

Not applicable.

3.3.5 Foundation Type

Not applicable.

3.3.6 Substructure

Not applicable.

3.3.7 Superstructure

Not applicable.

3.3.8 Articulation Arrangement

Not applicable.

3.3.9 Vehicle Restraint System

A Vehicle Restraint System (VRS) at this location is not required. Following a risk assessment in accordance with DN-GEO-03079 the speed of the road and curve results was deemed to cause a low risk of errant vehicles. Although there is no highway requirement it is recommended that a VRS is provided at the edge of the bus lane. This measure will prevent loading of the area beyond the bus lane which will not undergo load alleviation measures. This has the added benefit of mitigating the increase in risk of impact the wall parapet resulting from the reduction in distance to the traffic face.

Currently it is unknown whether the existing masonry upstand can resist these loads in accordance with modern design standards and it is unlikely that it could achieve adequate containment levels.

3.3.10 Drainage

Not applicable.

3.3.11 Durability

The geotextiles proposed as part of this solution typically have a design life of 100 years and therefore would not require maintenance during the expected remaining service life of the existing wall.

3.3.12 Sustainability

The chosen solution provides a low carbon option due to the lack of new concrete structures being built and retention of the existing wall.

3.3.13 Inspection and Maintenance

The proposed option requires an inspection and maintenance regime for the existing wall. No additional measures will be required beyond what is already required for the existing arrangement.

Inspections on the VRS would also take place every 2 years. Given the urban setting of this structure, graffiti may appear on the parapet walls which will need to be removed at regular intervals. If the problem persists, consideration should be given to finishing exposed surfaces with an anti-graffiti coating.

The new buried structure will not be directly inspected due to cost and issues regarding disruption to highway operations. However, evidence of structural distress such as cracking in the carriageway surfacing which would indicate movement should be recorded in the regular inspections.

4. Safety

4.1 Traffic Management during construction

The ground improvement works solution has a requirement to excavate into the existing highway, verge strip and cycle lane to install layers of geotextile material. There are also further potential excavation adjacent to the existing wall for soil replacement with lightweight fill. Therefore, the traffic management plan will be developed at a further stage of the design to accommodate these works.

4.2 Safety during construction

The Designer will take account of the General Principles of Prevention, as specified in the Schedule 3 of the Safety, Health and Welfare at Work Act 2005, liaise with the Project Supervisor appointed by the Client for the Design Process and the Project Supervisor appointed for the Construction Stage and carry out all other duties as required by Clause 15 of the Safety, Health and Welfare at Work (Construction) Regulations 2013 (S.I. No. 291 of 2013).

4.3 Safety in use

It is not expected that the proposed solution will change the risk profile associated with the service and maintenance of the existing wall. The face of the traffic will be brought closer to the wall but this shall be mitigated via the introduction of a VRS system.

4.4 Lighting

There are no lighting requirements for this structure beyond which is already in place for the existing arrangement.

5. Design Assessment Criteria

5.1 Actions

5.1.1 Permanent Actions

Permanent actions in accordance with IS EN 1991-1-1:2002 and the associated National Annex.

5.1.2 Snow, Wind and Thermal Actions

Snow actions are not considered in the design. Snow load is ignored in accordance with NA to IS EN 1990:2002.

Wind actions shall be in accordance with IS EN 1991-1-4 and the associated National Annex.

Thermal actions will be assessed in accordance with IS EN 1991-1-5 and the associated National Annex.

5.1.3 Actions Relating to Normal Traffic

Traffic actions shall be in accordance with IS EN 1991-2 and the associated National Annex. The application of traffic loads and distribution through the soil will be applied to the retaining walls in accordance with PD 6694-1:2011 (*Recommendations for the design of structures subject to traffic loading to BS EN 1997-1:2004*).

5.1.4 Actions Relating to Abnormal Traffic

Not applicable.

5.1.5 Footway or Footbridge Live Loading

Not applicable.

5.1.6 Provision for Exceptional Abnormal Loads

Abnormal loads not considered, subject to TAA confirmation

5.1.7 Accidental Actions

Not applicable.

5.1.8 Actions during Constructions

Not applicable.

5.1.9 Any Special Loading not Covered Above

A transient surcharge load will be applied to the ground behind the walls. The following non-concurrent loads have been considered in the design depending on the slope of the ground level behind the wall:

- 10 kPa Construction Surcharge (ground profile level behind the wall)
- 10 kPa Design Surcharge for slopes $\beta \leq 1V:6H$
- 5.0 kPa Design Surcharge for slopes $1V:6H < \beta \leq 1V:3H$
- 2.5 kPa Design Surcharge for slopes $\beta > 1V:3H$

5.2 Authorities consulted and any special conditions required

Principal project stakeholders have been consulted:

- Dún Laoghaire-Rathdown County Council;
- Transport Infrastructure Ireland;
- National Transport Authority.

The following utilities companies were consulted with on a scheme wide basis:

- ESB;
- GNI;
- Irish Water;
- Eir;
- Virgin Media.

5.3 Proposed Departures from Standards

These are no proposed departures from standards for these structures

5.4 Proposed methods of dealing with aspects not covered in standards

Not applicable.

6. Ground Conditions

6.1 Geotechnical Classification

Geotechnical Classification 2.

6.2 Ground Conditions

A high-level desk study has been undertaken looking at macro geological features and historic borehole data available for the area from the Geological Survey of Ireland (GSI). The GSI viewer indicates that the site is underlain by superficial deposits of Glacial Till. The underlying solid geology is shown to comprise dark blue-grey slate, phyllite & schist of the Maulin Formation. The natural topography falls gently from the west to the east. It appears that the wall was formed to contain fill that was placed to build the M11/N11 roundabout.

Six boreholes, excavated in 1984 as part of the construction of the Bray Shankill bypass, are believed to be in the immediate vicinity of the wall. The figure below shows the location of these boreholes.



Figure 6.1: Location of boreholes

The ground investigation report that contains these boreholes, includes a drawing that shows contours prior to construction. These contours also suggest that the ground was filled as part of the roundabout construction. It also indicates that Seaview Wood was built after the M11/N11 roundabout.

Three of the boreholes (BH1550A, BH1550B and BH1550C) are on a line at approximate chainage A14140. These have been added to the section provided in Figure 7.2b to illustrate the expected strata.

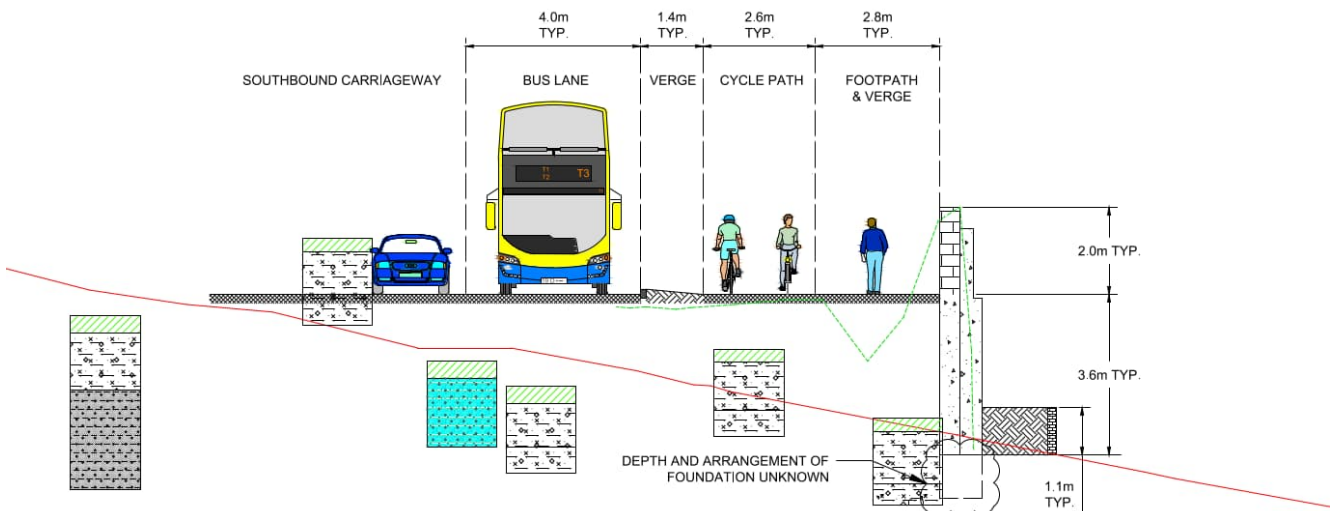

Figure 6.2: Section illustrating encountered strata's during 1984 boreholes. Red line shows historical ground level.

All the boreholes excavated in the vicinity of the wall encountered stiff Glacial Till (described as Boulder Clay on the logs), immediately below topsoil. None of the boreholes prove bedrock. The deepest borehole (1550A) was advanced to a level of 25.38 m and was terminated after proving 1.8m of Glacial Till. "No groundwater encountered" was noted on all the exploratory hole logs.

SPT N values noted on the logs range from 27 to 36 blows. This is consistent with the strength descriptions of stiff and hard that are provided on the logs. The Glacial Till is described as Boulder Clay, cobbles and boulders were noted on the log of BH1475 and are likely to be present throughout the stratum.

No information has been provided on the material used to fill the roundabout, although, as it appears to have been placed during road construction, it is likely that the fill would have had some degree of quality control and engineering.

Ground related considerations / risks:

- Made Ground is likely behind the wall.
- There is no information available on the nature of the Made Ground, particularly, it's effective angle of friction.
- Groundwater is unlikely to be present behind the wall, but it should be capable of resisting water associated with failure of the road drainage.
- The ground beneath the wall is expected to be stiff or hard Glacial Till.
- The thickness of Glacial Till is not none. This is only likely to be concern if strengthening works that require deep foundations are proposed

7. Drawings and Documents

7.1 List of All Documents Accompanying the Submission

Drawing Reference	Drawing Title	Revision
BCIDB-JAC-STR_GA-0013_XX_00-DR-SS-0040	Site Location Plan	M01
BCIDB-JAC-STR_GA-0013_RW_00-DR-CB-1111	General Arrangement	M01

Table 7.1: List of accompanying drawings

Relevant documents are included as appendices to this report.

Appendix A. **Drawings**

0 5.0 10.0 20.0 30.0 40.0 50.0m

SCALE 1:500 @ A1; 1:1000 @ A3

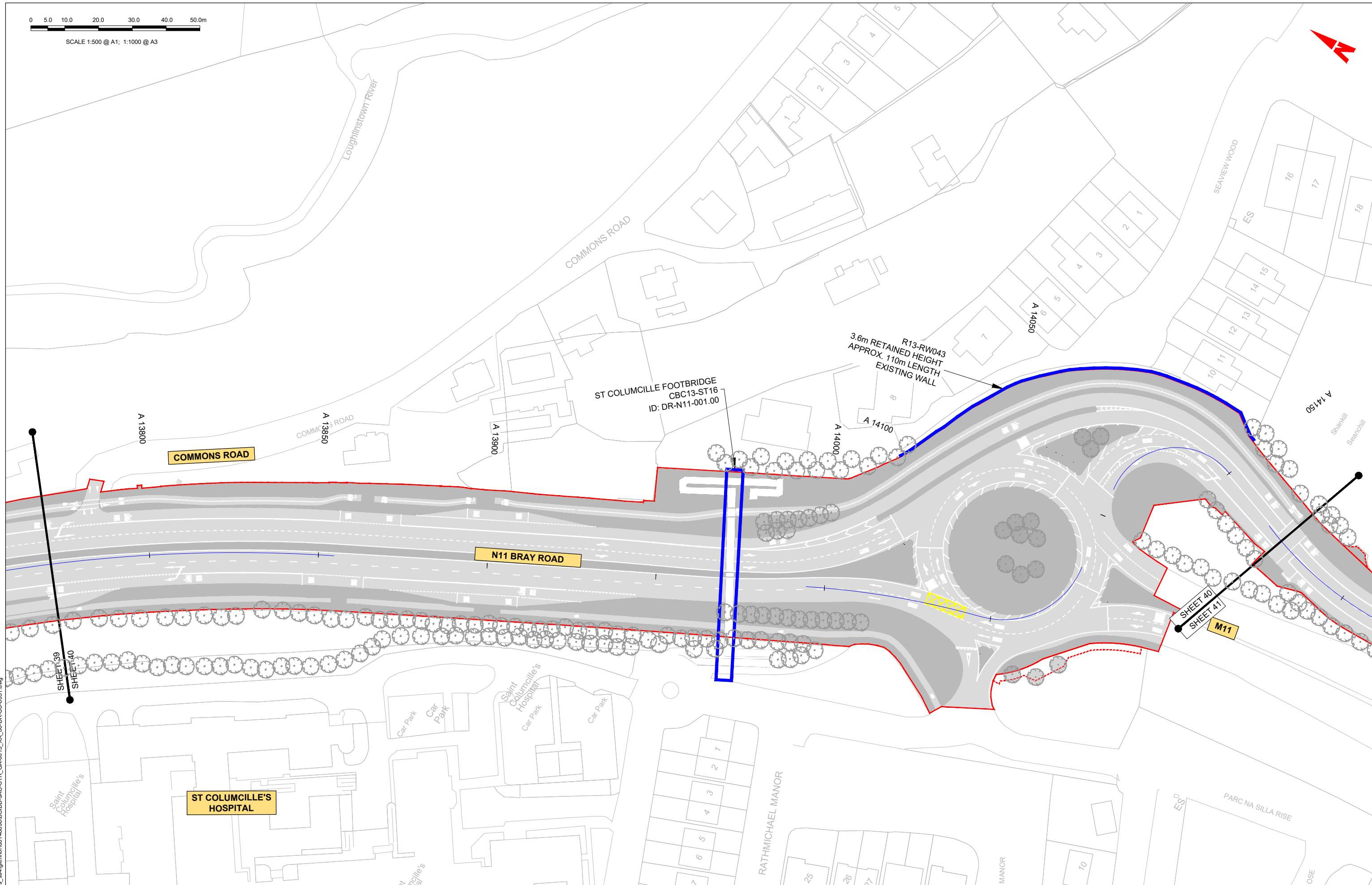

C:\pwworking\jacobs_uk_highways_ss4\glennor\0148698\BCIDB-JAC-STR_GA-0013_XX_00-DR-SS-0031.dwg

Disclaimer
a. © National Transport Authority (NTA) 2022. This drawing is confidential and the copyright in it is owned by NTA. This drawing must not be either loaned, copied or otherwise reproduced in whole or in part or used for any purpose without the prior permission of NTA.
b. This drawing is to be used for the design element identified in the titleblock. Other information shown is to be considered indicative only. The drawing is to be read in conjunction with all other relevant design drawings.
c. O.S. data used for plans are printed under © Ordnance Survey Ireland Government of Ireland. All rights reserved. Licence Number 2022/OS_NMA_180 National Transport Authority. All elevations are in metres and relate to OSi Geoid Model (OSGM15) Malin Head. All Co-ordinates are in Irish

Transverse Mercator Grid (ITM) as defined by OSI active local GPS station.
d. Information concerning the position of apparatus shown on this drawing is based on drawings supplied by the utility owners and/or the utility works contractor, whilst every care has been taken in the preparation of this drawing, positions should be taken as approximate and are intended for general guidance only and no representation is made by the NTA as to the accuracy, completeness, sufficiency or otherwise of this drawing and the position of the apparatus. The information contained herein does not purport to be comprehensive or final as the apparatus is subject to being altered and/or superceded. Recipients should not rely on this information. Any liabilities are hereby expressly disclaimed.

e. The information contained herein has been provided by the NTA but does not purport to be comprehensive or final. Recipients should not rely on the information. Neither the NTA nor any of its directors, officers, employees, agents, stakeholders or advisers make any representation or warranty as to, or accept any liability or responsibility in relation to, the adequacy, accuracy, reasonableness or completeness of the information provided as part of this document or any matter on which the information is based (including but not limited to loss or damage arising as a result of reliance by recipients on the information or any part of it). Any liabilities are hereby expressly disclaimed.



Rev	Date	Drm	Chk'd	App'd	Description
M01	27/01/2023	RG	JM	RS	ISSUE FOR PHASE 4: PLANNING

Client
NTA
Údarás Náisiúnta Iompair
National Transport Authority

Date: 27/01/2023
Scale: 1:500 @ A1
1:1000 @ A3

Project Code: BCIDB
Originator Code: JAC

Engineering Designer
Jacobs

Drawn: RG
Checked: JM
Approved: RS

QMS Code

Programme Title
**BUSCONNECTS DUBLIN
CORE BUS CORRIDORS INFRASTRUCTURE WORKS**

Drawing Title
BRAY TO CITY CENTRE SCHEME
STRUCTURES GENERAL ARRANGEMENT

Drawing File Name
BCIDB-JAC-STR_GA-0013_XX_00-DR-SS-0040

Sheet Number
40 of 54

Status
A

Rev
M01

DO NOT SCALE USE FIGURED DIMENSIONS ONLY

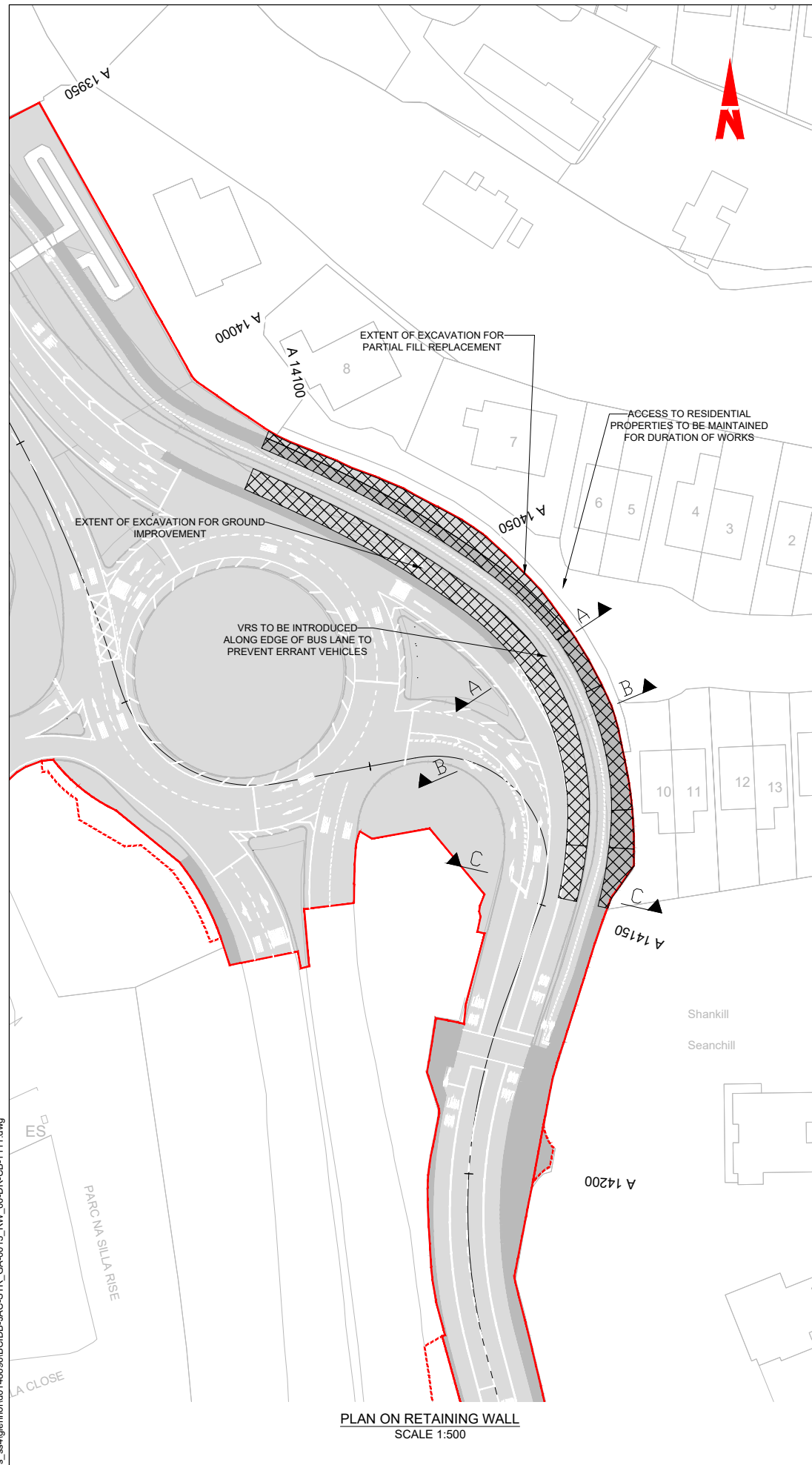

PLAN ON RETAINING WALL
SCALE 1:500

CROSS SECTION A-A
PROPOSED LAYOUT
SCALE 1:100

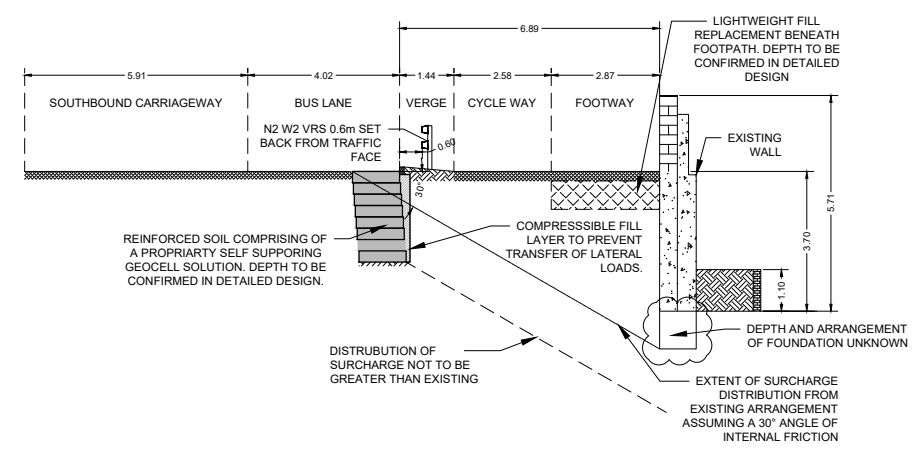

CROSS SECTION B-B
PROPOSED LAYOUT
SCALE 1:100

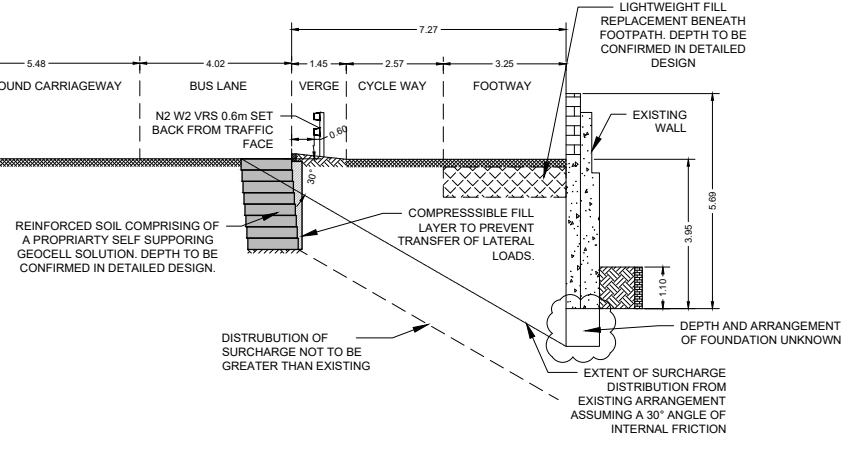

CROSS SECTION C-C
PROPOSED LAYOUT
SCALE 1:100

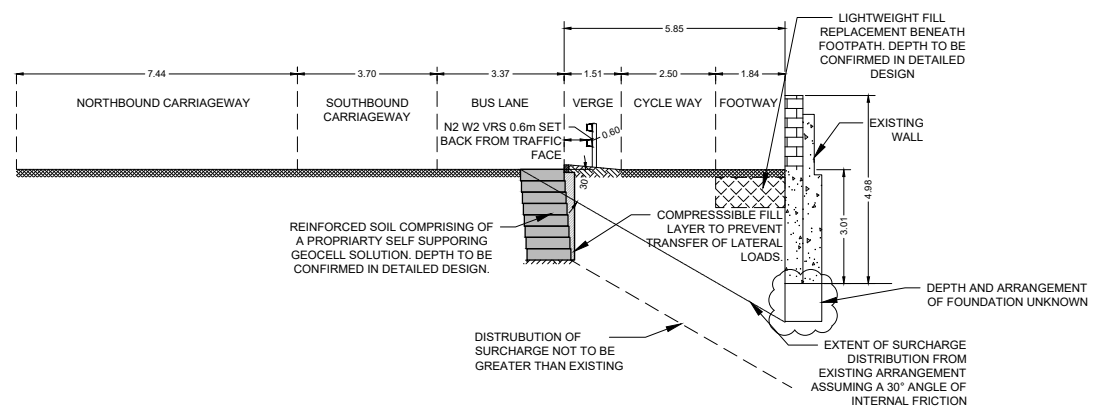

- NOTES :
1. ALL DIMENSIONS ARE SHOWN IN METRES UNLESS NOTED OTHERWISE.
 2. CARRIAGEWAY, VERGE, CYCLE LANE AND FOOTPATH ARE OF VARYING WIDTH ALONG WALL LENGTH.

C:\pwworking\jacobs_uk_highways_ssa4\glennor\0148698\BCIDB-JAC-STR_GA-0013_RW_00-DR-CB-1111.dwg

Disclaimer

a. © National Transport Authority (NTA) 2022. This drawing is confidential and the copyright in it is owned by NTA. This drawing must not be either loaned, copied or otherwise reproduced in whole or in part or used for any purpose without the prior permission of NTA.

b. This drawing is to be used for the design element identified in the titleblock. Other information shown is to be considered indicative only. The drawing is to be read in conjunction with all other relevant design drawings.

c. O.S. data used for plans are printed under © Ordnance Survey Ireland Government of Ireland. All rights reserved. Licence Number 2022/O.S._NMA_180 National Transport Authority. All elevations are in metres and relate to OSI Geoid Model (OSGM15) Mean Head. All Co-ordinates are in Irish Transverse Mercator Grid (ITM) as defined by OSI active local GPS station.

d. Information concerning the position of apparatus shown on this drawing is based on drawings supplied by the utility owners and/or the utility works contractor, whilst every care has been taken in the preparation of this drawing, positions should be taken as approximate and are intended for general guidance only and no representation is made by the NTA as to the accuracy, completeness, sufficiency or otherwise of this drawing and the position of the apparatus. The information contained herein does not purport to be comprehensive or final as the apparatus is subject to being altered and/or superseded. Recipients should not rely on this information. Any liabilities are hereby expressly disclaimed.

e. The information contained herein has been provided by the NTA but does not purport to be comprehensive or final. Recipients should not rely on the information. Neither the NTA nor any of its directors, officers, employees, agents, stakeholders or advisers make any representation or warranty as to, or accept any liability or responsibility in relation to, the adequacy, accuracy, reasonableness or completeness of the information provided as part of this document or any matter on which the information is based (including but not limited to loss or damage arising as a result of reliance by recipients on the information or any part of it). Any liabilities are hereby expressly disclaimed.



Rev	Date	Drn	Chk'd	App'd	Description
M01	27/01/2023	RG	JM	RS	ISSUE FOR PHASE 4: PLANNING

Client: **NTA**
Údarás Náisiúnta Iompair
National Transport Authority

Engineering Designer: **Jacobs**

Date: 27/01/2023
Project Code: BCIDB
Originator Code: JAC

Scales shown @ A1 as shown @ A3

Drawn: RG
Checked: JM
Approved: RS

QMS Code

Programme Title BUSCONNECTS DUBLIN CORE BUS CORRIDORS INFRASTRUCTURE WORKS			
Drawing Title BRAY TO CITY CENTRE SCHEME DUN LAOGHAIRE-RATHDOWN COUNTY COUNCIL GENERAL ARRANGEMENT R13-RW043			
Drawing File Name BCIDB-JAC-STR_GA-0013_RW_00-DR-CB-1111	Sheet Number 01 of 1	Status A	Rev M01

DO NOT SCALE USE FIGURED DIMENSIONS ONLY



Appendix F4
St Annes Retaining Wall
Preliminary Design Report

© Copyright 2023 Jacobs Engineering Ireland Limited. The concepts and information contained in this document are the property of Jacobs. Use or copying of this document in whole or in part without the written permission of Jacobs constitutes an infringement of copyright.

Limitation: This document has been prepared on behalf of, and for the exclusive use of Jacobs' client, and is subject to, and issued in accordance with, the provisions of the contract between Jacobs and the client. Jacobs accepts no liability or responsibility whatsoever for, or in respect of, any use of, or reliance upon, this document by any third party.

**Preliminary Design Report-
Consultation**

STA-1b

Categories 1, 2 & 3

Scheme Name

Name and Location – BusConnects Route 13 Bray to City Centre, Dublin

Structure(s)

Name and nature of the Structure(s) – St Anne’s Roundabout Retaining Wall

Structures Options Report

Reference - R13-RW046

Revision - M01

Date - 27th January 2023

Submitted by

Signed  _____

Name John McElhinney

Position Structural Discipline Lead (Team Leader)

Organisation Jacobs Engineering

Date 27/01/2023

Structures Section confirmation of consultation

Signed _____

Name _____

Position _____

Date _____

* This application should appear as the first page after the cover of the Preliminary Design Report.

Contents

1.	Introduction.....	1
1.1	Brief.....	1
1.2	Background.....	1
1.3	Previous Studies.....	2
2.	Site & Function.....	3
2.1	Site Location.....	3
2.2	Function of Site and Obstacles Crossed.....	3
2.3	Choice of location.....	3
2.4	Site Description and Topography.....	4
2.5	Vertical and Horizontal Alignments.....	4
2.6	Cross Sectional Dimensions.....	5
2.7	Existing Underground and Overground Services.....	6
2.8	Geotechnical Summary.....	6
2.9	Hydrology and Hydraulic Summary.....	7
2.10	Archaeological Summary.....	7
2.11	Environmental Summary.....	7
3.	Structure & Aesthetics.....	9
3.1	General Description of Recommended Structure and Design Working Life.....	9
3.2	Aesthetic Considerations.....	9
3.3	Proposals for the Recommended Structure.....	10
3.3.1	Proposed Category.....	10
3.3.2	Span Arrangement.....	10
3.3.3	Minimum Headroom Provided.....	10
3.3.4	Approaches including run-on arrangements.....	10
3.3.5	Foundation Type.....	10
3.3.6	Substructure.....	10
3.3.7	Superstructure.....	10
3.3.8	Articulation Arrangement.....	10
3.3.9	Vehicle Restraint System.....	10
3.3.10	Drainage.....	11
3.3.11	Durability.....	11
3.3.12	Sustainability.....	11
3.3.13	Inspection and Maintenance.....	11
4.	Safety.....	12
4.1	Traffic Management during construction.....	12
4.2	Safety during construction.....	12
4.3	Safety in use.....	12
4.4	Lighting.....	12
5.	Design Assessment Criteria.....	13
5.1	Actions.....	13

5.1.1	Permanent Actions.....	13
5.1.2	Snow, Wind and Thermal Actions.....	13
5.1.3	Actions Relating to Normal Traffic	13
5.1.4	Actions Relating to Abnormal Traffic.....	13
5.1.5	Footway or Footbridge Live Loading.....	13
5.1.6	Provision for Exceptional Abnormal Loads.....	13
5.1.7	Accidental Actions.....	13
5.1.8	Actions during Constructions.....	13
5.1.9	Any Special Loading not Covered Above.....	13
5.2	Authorities consulted and any special conditions required.....	13
5.3	Proposed Departures from Standards	14
5.4	Proposed methods of dealing with aspects not covered in standards.....	14
6.	Ground Conditions.....	15
6.1	Geotechnical Classification	15
6.2	Ground Conditions	15
7.	Drawings and Documents	16
7.1	List of All Documents Accompanying the Submission.....	16

1. Introduction

1.1 Brief

Jacobs have been appointed by the National Transport Authority (NTA) to undertake the Engineering Design Services for the Planning Stage through to the end of the Statutory Process of the BusConnects Radial Core Bus Corridors Infrastructure Upgrade Programme (the Programme). The Project has been split in four packages with Jacobs undertaking Package B.

This report outlines the Preliminary Design for the St Anne’s Roundabout Retaining Wall (wall reference: R13-RW046) in Shankill on the CBC 13 Bray to City Centre route.

1.2 Background

The National Transport Authority (NTA) published the Transport Strategy for the Greater Dublin Area, 2016 – 2035 at the beginning of 2016. The strategy identifies a “Core Bus Network”, representing the most important bus routes within the Greater Dublin area, generally characterised by high passenger volumes, frequent services, and significant trip attractors along the routes. The identified core network comprises sixteen radial bus corridors, three orbital bus corridors and six regional bus corridors.

The Strategy states that it is intended to provide continuous bus priority, as far as is practicable, along the core bus routes. This will result in a more efficient and reliable bus service with lower journey times, increasing the attractiveness of public transport in these areas and facilitating a shift to more sustainable modes of transport. The Bray to City Centre Core Bus Corridor is identified as part of the Core Bus Network.

In March 2018, BusConnects Dublin was launched as part of major investment programme, including Metrolink and the Dublin Area Rapid Transport (DART) Expansion Programme, to improve public transport in Dublin, as part of the National Development Plan 2018-2027. The Bray to City Centre CBC serves the area to the south of Dublin city, creating an improved public transportation link for areas along the corridor.

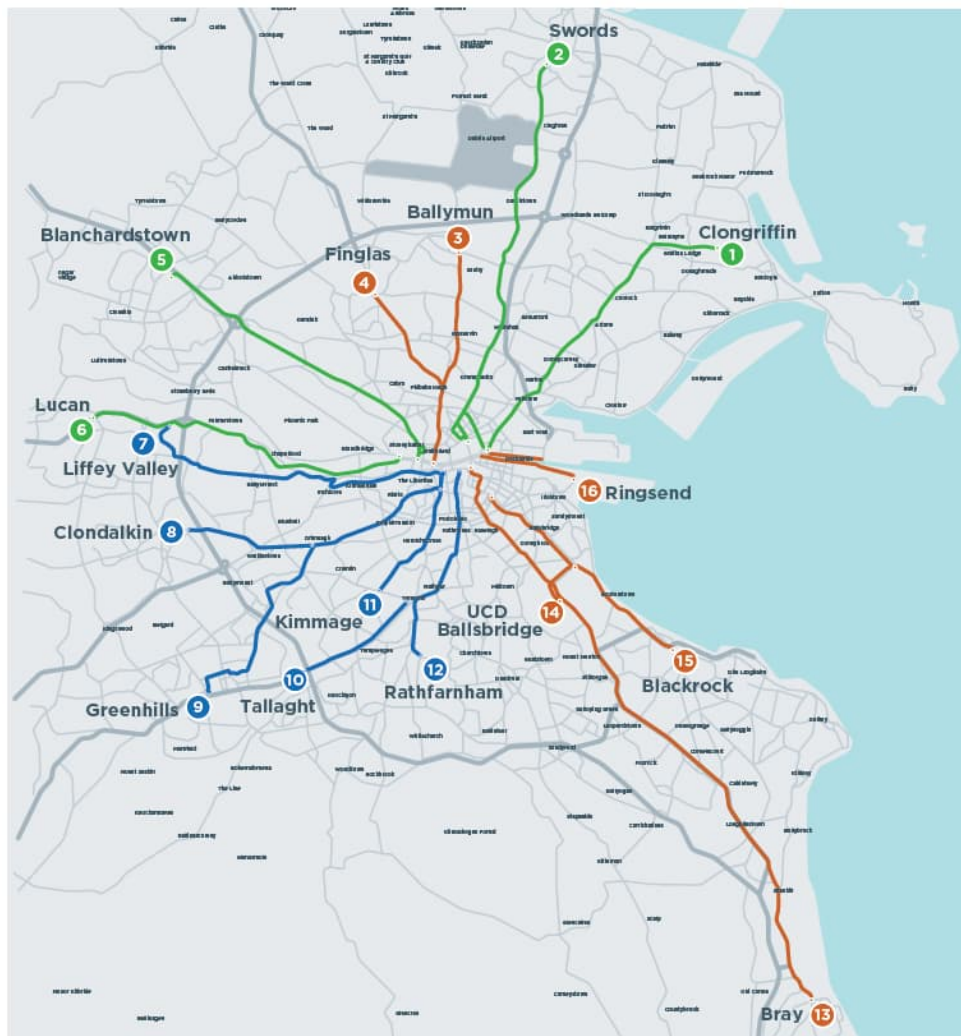

Figure 1.1: BusConnects Dublin Radial CBC Network

1.3 Previous Studies

The first non-statutory public consultation on the BusConnects CBCs took place on a phased basis between November 2018 and May 2019. The second round of public consultations occurred between March 2020 and April 2020. A third round of public consultations then followed between November 2020 and December 2020.

Consultation with the principal project stakeholders (i.e. Dublic City Council, Transport Infrastructure Ireland, Utility companies and the National Transport Authority) has also taken place.

A desktop study was undertaken to identify the existing structures within the project extents, with site inspections undertaken where information was limited.

2. Site & Function

2.1 Site Location

The St Anne’s Roundabout Retaining Wall is located approximately 17 km south of Dublin City Centre (ITM Grid Reference: 725263E, 721927N)

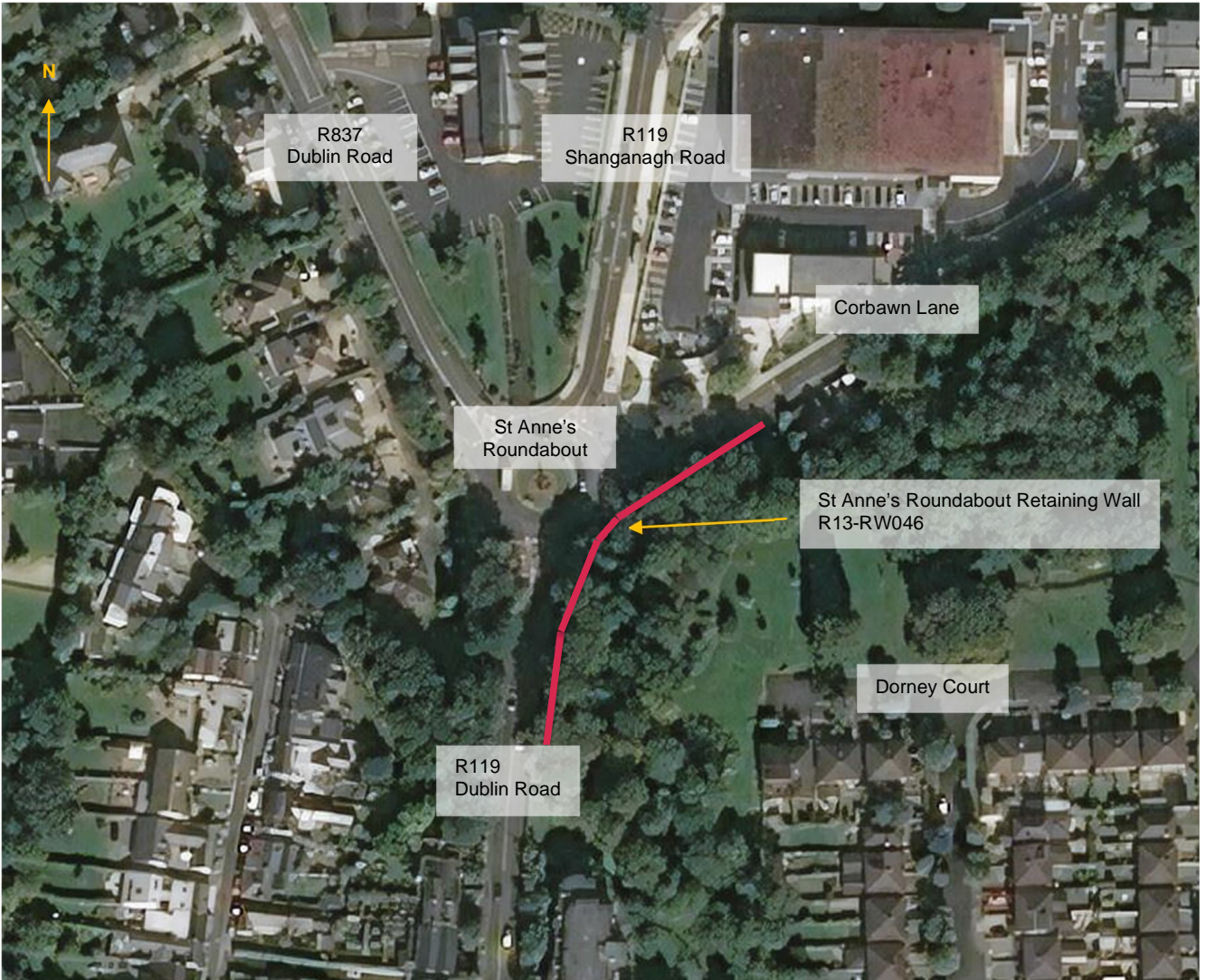

Figure 2.1: Plan view of St Anne’s Roundabout Retaining Wall and surrounding features

2.2 Function of Site and Obstacles Crossed

The St Anne’s Roundabout Retaining Wall retains the footway to the east of the roundabout along the R119 & Corbawn Lane. A green space separating a residential development lies immediately to the east of the structure. The roundabout is located entirely within the boundaries of Dún Laoghaire-Rathdown County Council (DLRCC) and is owned and maintained by DLRCC.

2.3 Choice of location

The location of works is determined by the site location and features described above. R13-RW046 will constitute works in the same location as the existing structure.

2.4 Site Description and Topography

Immediately behind the wall is a footway which varies in width from 6m to 2m with the wider sections further north. A verge is included in sections adjacent to the junction with tactile paving provided, effectively reducing the footway width in this section to approximately 3m. The face of traffic from the structure varies in distance along its length from 6m to 2m. Various underground utilities were identified beneath the retained ground, including 3 No. low voltage assets, 2 No. water assets, a low-pressure gas asset, and two data assets immediately behind the wall.

In front of the wall is a heavily vegetated green space adjacent to a residential development. At the southern section of the wall there is a bridge carrying Dublin Road over a disused rail line. Visibility on the front face of the wall is obstructed due to the presence of heavy vegetation, therefore this wall is not particularly sensitive to visual changes. This space is believed to be owned by a private developer and is currently maintained by DLRCC as a park area as part of a planning agreement for the adjacent properties.

Historical records indicate that the face of traffic used to be significantly closer to the structure, in the region of 2m to 3m, however the accuracy and validity of this information is difficult to verify.



Figure 2.2: View of R13-RW046 from Dublin Road

2.5 Vertical and Horizontal Alignments

The highway proposals at this location consist of reconfiguring the existing roundabout into a signalised junction. This would result in a reduction of the existing footway from 6m to approximately 3m and the inclusion of a cycleway which will terminate south of the new junction, prior to the pinch point at the existing bridge. This would bring the footway width and face of traffic more in line with the historic alignment for which the original wall should have been designed.

The proposed alignment changes are shown in Figure 2.3 and 2.4

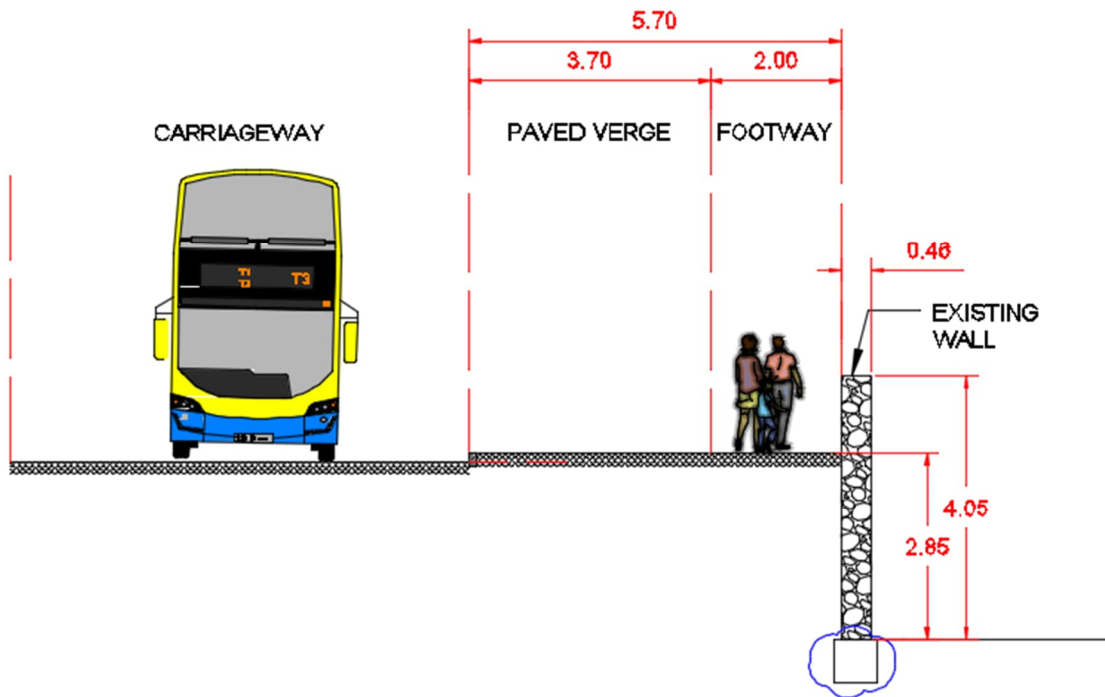

Figure 2.3: Typical existing cross section of highway alignment

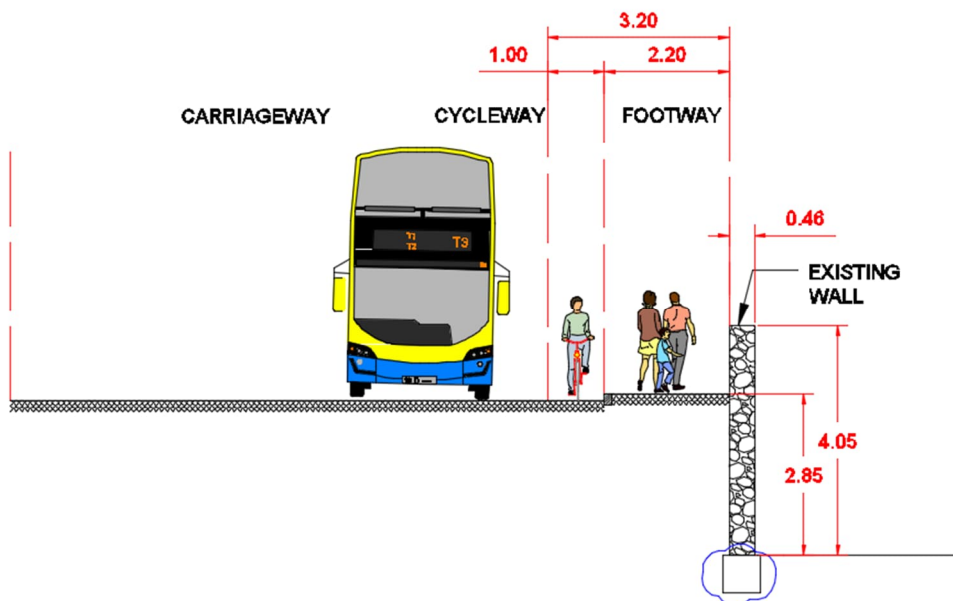

Figure 2.4: Typical proposed cross section of highway alignment

2.6 Cross Sectional Dimensions

Refer to drawing BCIDB-JAC-STR_GA-0013_RW_00-DR-CB-1110 in Appendix A – Drawings for the cross-sectional dimensions of R13-RW046.

2.7 Existing Underground and Overground Services

The following analysis is based on the utility records provided by the relevant utility providers. There are several existing utility assets located behind the existing retaining wall beneath areas of proposed excavation works.

Overhead low voltage cables are located along the entire length of the wall and this will limit the use of plant and lifting operations.

There are several utilities in the zone between the back of the existing kerb line and the rear face of the retaining wall. Their alignment with respect to the structure varies significantly over the length of the structure. These utilities include a 100mm, 150 mm and 200mm water mains, Eir ducts and chambers, a 250 mm low pressure gas main, low voltage ESB overhead cabling, Virgin Media ducting and chambers. The records and surface features indicate that the utilities involved are largely outside the footprint of the proposed bus lane widening which will result in the utilities being located beneath the proposed cycle lane and footway if left in-situ. Therefore, the level of disruption to existing utility assets will vary significantly depending on which option advances. There are limited options available for utility relocations in this area due to land availability should they be required.

There is existing road drainage infrastructure along this section of the scheme. Any option proposed will need to cater for the drainage design as specified in other documentation produced for this scheme.

A schedule of identified clashes can be seen in Table 2.1.

Underground Services	Overground Services
<p><u>Irish Water</u> 150 mm DIA water main asset in the footway running parallel with the wall on Dublin Rd. 200mm DIA water main on Corbawn Lane footway adjacent to the wall. 100mm DIA water main on the carriageway of Corbawn Lane that crossed into the footway of Dublin Rd in the vicinity of the wall.</p> <p><u>GNI (Gas)</u> 125 mm GNI low pressure gas main in the footway of Dublin road and Corbawn Lane parallel to the existing wall.</p> <p><u>Telecommunications (Eir & Virgin Media)</u> Eir ducts and chambers and cabinets beneath the existing footway on Dublin Rd and Corbawn Lane. Virgin Media ducting and chambers beneath the existing footway on Corbawn Lane and Dublin Road close to the existing roundabout.</p>	<p><u>ESB (Electricity)</u> Overhead low voltage ESB along alignment of wall on Dublin Road.</p>

Table 2.1: Summary of existing utilities

2.8 Geotechnical Summary

A geotechnical desktop study of the area has been undertaken using publicly available information and Ground Investigation reports available through the Geological Survey of Ireland.

Refer to Section 7 for details of the ground conditions at each retaining wall location.

2.9 Hydrology and Hydraulic Summary

It is not expected that the construction of the proposed subway will have any significant impact on the local hydrogeology.

2.10 Archaeological Summary

There are no recorded areas of significant archaeological importance in the vicinity of the R13-RW046.

2.11 Environmental Summary

Mature trees are present in front of the wall and these features will be retained and protected for all the proposed options. Clearance of weeds and understorey vegetation immediately adjacent to the wall is required in all instances to provide a safe and accessible working area. This may also include some lower branch removal to the retained trees. The removal of the understorey vegetation is not considered to be a significant environmental impact. Ground protection mats will be utilised to avoid compaction and damage to the root protection zone of the trees and the tree trunks will be physically protected with an appropriate and approved wrapping.

This location has the potential to be a habitat for bats and/or other protected species. This will be considered as part of the Environmental Impact Assessment.

Aside from the impacts on the trees it is not considered that the proposed option will have a significant impact on any other aspects of the environment. There are no water courses or ecologically designated sites near the structure. It is not anticipated that soil on site has been exposed to contamination.

An Environmental Impact Assessment (EIA) Scoping Report is being progressed currently, which will set out in greater detail the baseline, data collection requirements and methodologies to be used to assess each route.

During construction the adverse environmental impacts that may occur, include:

- Construction noise and vibration;
- Generation of dust;
- Vegetation removal;
- Deposition of mud on roads;
- Accidental spillage of fuels, oil, or other materials;
- Clashes with utilities;
- Ground compaction;
- Potential for contaminated land in excavations;
- Visual intrusion
- Effects on local ecology.

These may be controlled and minimised through good site practice and dedicated environmental management. The new structures will be constructed in accordance with latest standards and recommendations for durability to maximise service life and reduce long-term requirements. The choice of materials used in the preferred option will affect the environmental impact of the solution.

Concrete elements shall use cement replacement materials, such as ground granulated blast-furnace slag, to reduce the associated carbon footprint. At the end of its service life the concrete elements can be recycled through use as an aggregate replacement or as usage as an engineering fill.

Consultation with the appropriate local authority environmental health departments will be required, to agree limits for noise and vibration. Where noise levels cannot be controlled at the source, the use of enclosures and barriers should be considered. Demolition methods will be chosen to minimise dust generation.

3. Structure & Aesthetics

3.1 General Description of Recommended Structure and Design Working Life

Three main options were considered in the options report to accommodate the widened highway cross section at the R13-RW046. The preferred option is installation of soil nails, due to the minimal impact on the traffic management on Dublin Road and the effectiveness of the solution.

This option consists of the installation of a row of proprietary soil nails through the front face of the masonry wall in the areas where there is an expected increase in traffic surcharge. The nails would act to restrain the wall against lateral movement when load is applied, effectively changing the boundary conditions and reducing the maximum bending moment developing in the wall. This would create a more efficient structural system allowing for the increase in load to be accommodated without a corresponding increase in internal stresses. This approach would allow for the re-use of the wall without the need to quantitatively confirm the capacity if the internal forces can be reduced from the existing.

Soil nails are typically 4m to 12m in length and are installed at an incline to help engage the soil and aid in the grouting operation. They form a passive system with the nail only engaging if the wall begins to move, this avoids introducing additional stresses which would arise from the use of an active system. Given the proximity of utilities and relatively shallow depth of installation it is anticipated that the nails would be installed at a negative inclination less than 10° to the horizontal and installed below the level of the existing utilities apparatus. Design of soil nails shall be in accordance with IS EN 1537 and IS EN 1997.

The risk of differential deflection between the loaded and unloaded sections of the wall was considered and deemed to be negligible. Given that the nails will prevent further movement of this section of the wall and the remaining section is not expected to deflect any further than existing conditions then the likelihood of differential deflection is low. Therefore, the extent of the nails will be limited to the sections of the wall which are expected to be subjected to an increase in highway surcharge. Consideration should be given to the use of proprietary facing products between the nails to reduce the risk of the development of cracks around and between the face plates. This should be evaluated during detailed design.

Construction works are only required in front of the wall therefore there is no direct impact to highway operations on Dublin Road apart from excavation work to prove clearance from existing utilities and any potential diversion requirements that result. As part of the proposals to protect the utilities apparatus the fill located under the east footway would be removed prior and during installation of the nails. Therefore, the nails will be fully installed when the fill is reintroduced in this section and will consist of loose uncompacted fill. Therefore, this area would be considered to be ineffective and the depth of embedment of the nails should be chosen with this constraint in mind.

There is sufficient space at the front face of the wall for the mobilisation of the plant required to install the nails. Method of installation will be governed by encountered ground conditions, but it is reasonable to assume that installation could be conducted via utilisation of a mini piling rig. This approach could be used to generate the required forces while being practical to manoeuvred through the wooded area with some limited vegetation removal.

3.2 Aesthetic Considerations

R13-RW046 has a high visual significance in the area, where much of the exposed structure is visible from Dublin Road. It forms part of the character of the area and is closely associated with R13—RW045 which is located on the west side of the carriageway. Any change to the visible parts of R13-RW046 would be contrasted against R13-RW045 which will need to be considered carefully. The visual appearance of the front face of the wall is of lesser significance as this is for the most part obscured by heavy vegetation.

The option involves a buried solution which will not be visible to the public. The existing wall will remain in place for this option and the existing appearance retained from the highway side. Vegetation found to climb up and root itself into the wall and parapet should be cleared every 2 years as part of the wall maintenance, but any trees located on the lower side should be retained.

3.3 Proposals for the Recommended Structure

3.3.1 Proposed Category

The retained height is smaller than 5m, hence the wall is classified as Category 1 structure in accordance with DN-STR-03001.

3.3.2 Span Arrangement

Not applicable.

3.3.3 Minimum Headroom Provided

Not applicable.

3.3.4 Approaches including run-on arrangements

Not applicable.

3.3.5 Foundation Type

Not applicable.

3.3.6 Substructure

Not applicable.

3.3.7 Superstructure

Not applicable.

3.3.8 Articulation Arrangement

Not applicable.

3.3.9 Vehicle Restraint System

The existing parapet arrangement consists of a masonry wall with a typical thickness, as measured on site, of 460mm and height varying from 1.6m to 0.9m along the length of the wall. This results in some sections of the parapet having a substandard height of less than the 1250mm requirement on new structures. Remedial works to raise substandard parapets are not typically undertaken unless parapet upgrading is required for vehicular containment.

An assessment of the capacity of the parapet was undertaken in accordance with the methodology set out in BS 6779-4. There is no equivalent standard in the TII library, so use of this is deemed to be appropriate in this scenario. Assuming a low mortar adhesion, 50 kph, and a 2200 kg/m³ density. It can be seen in Figure 4 of the standard, that the minimum thickness of parapet required to achieve the stated normal containment level is 380mm, which is less than the measured 460mm encountered on site. See table 3.1 for a comparison of normal containment and N2 containment from BS 6779-4 and DN-REQ-03034 respectively.

Parameter	BS 6779-4	DN-REQ-03034
Weight of vehicle	1500 kg	1500 kg
Speed of vehicle	113 kph	110 kph
Angle of impact	20°	20°
Height of force application	480mm – 580mm	Not stated

Table 3.1: Comparison of loading for containment levels

Table 3.3.9 above shows that the loading used in BS 6779-4 is comparable to the current standards used in Irish guidance documents with the old British Standard being slightly more onerous. Therefore, the conclusions gained from the use of the methodology set out in BS 6779-4 are deemed to be valid in this situation. Given this, it is not proposed that any upgrading or strengthening of the parapet be undertaken since this would have a significant impact on the local visual environment.

Whilst the parapet height is insufficient for cycle requirements, there is no proposed dedicated cycle lane along this section and the kerbline is set a distance of 2m from the existing parapet. Additional mitigation to the risk to cyclists may be considered in Detailed Design. The condition of the parapet should also be reviewed in the detailed design phase for parapets on both sides of the highway, to identify any local repairs that may be required at that time.

3.3.10 Drainage

Not applicable.

3.3.11 Durability

The soil nails have a design life of 60 years and would therefore require replacement during the design life of the structure. This can be increased to 120 years with the inclusion of sacrificial steel and use of galvanised bars if the soil conditions are found to be non-aggressive. Use of stainless steel was considered but due to current lead times in the procurement and the higher associated cost this was considered to not be a cost-effective solution. If further ground investigation finds that the soil is particularly aggressive then stainless steel may be the only option to achieve the desired design life.

3.3.12 Sustainability

The chosen solution presents a sustainable solution by virtue of reusing existing infrastructure as opposed to complete reconstruction.

3.3.13 Inspection and Maintenance

All options will require an inspection and maintenance regime for the existing wall. This would involve a regiment of inspections at regular intervals and maintenance works carried out as required proportional to priority of the defect. Repointing of the masonry should be carried out as required throughout the remaining structure design life. Given the urban setting of this structure, graffiti may appear on the parapet walls which will need to be removed at regular intervals. If the problem persists, consideration should be given to finishing exposed surfaces with an anti-graffiti coating.

4. Safety

4.1 Traffic Management during construction

It is expected that traffic management will need to be introduced on the east side of the carriageway due to the need to expose the utilities for visual confirmation of the installation of the nails. This would likely involve closure of the southbound lane for the extent of the proposed works and the diversion of pedestrians from the east footway to the west footway. This structural solution will require some amount of width restriction to the carriageway during installation with temporary VRS introduced approximately 1m offset from the southbound kerb to accommodate the excavation works in the footway. The traffic management plan will be developed at a further stage of the design to accommodate these works.

4.2 Safety during construction

The Designer will take account of the General Principles of Prevention, as specified in the Schedule 3 of the Safety, Health and Welfare at Work Act 2005, liaise with the Project Supervisor appointed by the Client for the Design Process and the Project Supervisor appointed for the Construction Stage and carry out all other duties as required by Clause 15 of the Safety, Health and Welfare at Work (Construction) Regulations 2013 (S.I. No. 291 of 2013).

Some excavation would be required to expose the utilities and visually confirm that no clashes with the nails occur. The soil nails would be installed below the level of the utilities therefore the risk of utility clashing is less than the other intrusive options. Mobilisation of plant to the lower side of the wall would create some challenges with the need to provide access and egress and the need to remove vegetation.

4.3 Safety in use

It is not expected that the proposed solution will change the risk profile associated with the service and maintenance of the existing wall.

4.4 Lighting

There are no lighting requirements for this structure beyond which is already in place for the existing arrangement.

5. Design Assessment Criteria

5.1 Actions

5.1.1 Permanent Actions

Permanent actions in accordance with IS EN 1991-1-1:2002 and the associated National Annex.

5.1.2 Snow, Wind and Thermal Actions

Snow actions are not considered in the design. Snow load is ignored in accordance with NA to IS EN 1990:2002.

Wind actions shall be in accordance with IS EN 1991-1-4 and the associated National Annex.

Thermal actions will be assessed in accordance with IS EN 1991-1-5 and the associated National Annex.

5.1.3 Actions Relating to Normal Traffic

Traffic actions shall be in accordance with IS EN 1991-2 and the associated National Annex . The application of traffic loads and distribution through the soil will be applied to the retaining walls in accordance with PD 6694-1:2011 (*Recommendations for the design of structures subject to traffic loading to BS EN 1997-1:2004*).

5.1.4 Actions Relating to Abnormal Traffic

Not applicable.

5.1.5 Footway or Footbridge Live Loading

Not applicable.

5.1.6 Provision for Exceptional Abnormal Loads

Abnormal loads not considered, subject to TAA confirmation

5.1.7 Accidental Actions

Not applicable.

5.1.8 Actions during Constructions

Not applicable.

5.1.9 Any Special Loading not Covered Above

A transient surcharge load will be applied to the ground behind the walls. The following non-concurrent loads have been considered in the design depending on the slope of the ground level behind the wall:

- 10 kPa Construction Surcharge (ground profile level behind the wall)
- 10 kPa Design Surcharge for slopes $\beta \leq 1V:6H$
- 5.0 kPa Design Surcharge for slopes $1V:6H < \beta \leq 1V:3H$
- 2.5 kPa Design Surcharge for slopes $\beta > 1V:3H$

5.2 Authorities consulted and any special conditions required

Principal project stakeholders have been consulted:

- Dún Laoghaire-Rathdown County Council;
- Transport Infrastructure Ireland;
- National Transport Authority.

The following utilities companies were consulted with on a scheme wide basis:

- ESB;
- GNI;
- Irish Water;
- Eir;
- Virgin Media.

5.3 Proposed Departures from Standards

These are no proposed departures from standards for these structures

5.4 Proposed methods of dealing with aspects not covered in standards

Not applicable.

6. Ground Conditions

6.1 Geotechnical Classification

Geotechnical Classification 2.

6.2 Ground Conditions

Ground conditions at the structure have been assessed using publicly available information including geological maps, hydrogeological information, publicly available ground investigations and historic mapping. The ground conditions at this location are assumed to comprise Till derived from limestones (Dublin Boulder Clay) overlying bedrock geology of dark blue-grey slate, phyllite and schist of the Maulin Formation. Thickness of superficial deposits are unconfirmed, publicly available borehole information indicate a minimum thickness of 5m. Publicly available GI reports for historical ground investigations to the south and west of the retaining wall (GSI External Report Refs: 5260, 6512, 6536, Figure 7-1) indicated the natural superficial geology of the area is generally described as firm to very stiff clay. The retaining walls are expected to be founded on Dublin Boulder Clay. Historical ground investigations in the area have recorded thicknesses of made ground between 1.5m and 2.5m. It is anticipated made ground in the form of engineered fill will be recorded behind and below the wall.

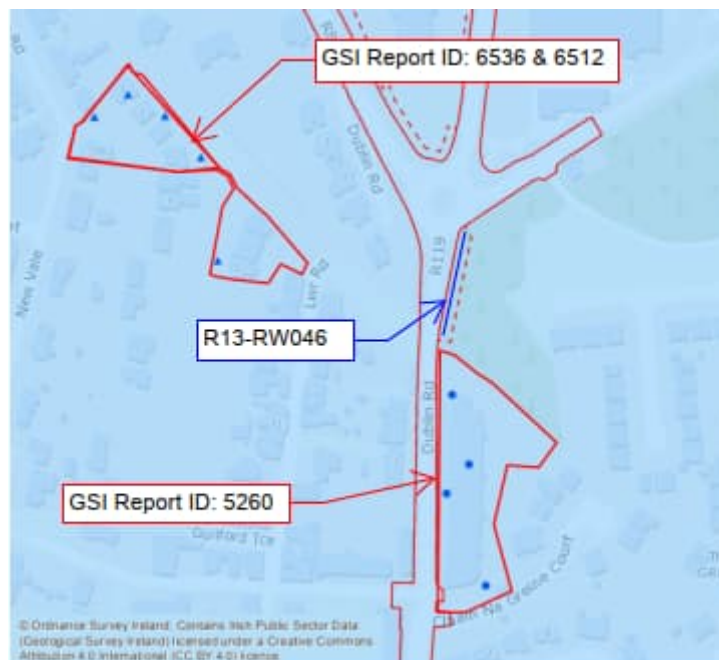

Figure 6-1 Location of historical GI.

Groundwater was encountered at a number of the historic locations, with seepages recorded at depths of between 4.4m bgl and 9.5m bgl. Soakaway tests carried out to the west of the roundabout recorded seepages in gravel layers at 1.2m bgl to 2.0m bgl. The seepages resulted in water levels rising in the trial pit in the duration of the 60-minute test.

7. Drawings and Documents

7.1 List of All Documents Accompanying the Submission

Drawing Reference	Drawing Title	Revision
BCIDB-JAC-STR_GA-0013_XX_00-DR-SS-0043	Site Location Plan	M01
BCIDB-JAC-STR_GA-0013_RW_00-DR-CB-1110	General Arrangement	M01

Table 7.1: List of accompanying drawings

Relevant documents are included as appendices to this report.

Appendix A. **Drawings**

0 5.0 10.0 20.0 30.0 40.0 50.0m

SCALE 1:500 @ A1; 1:1000 @ A3

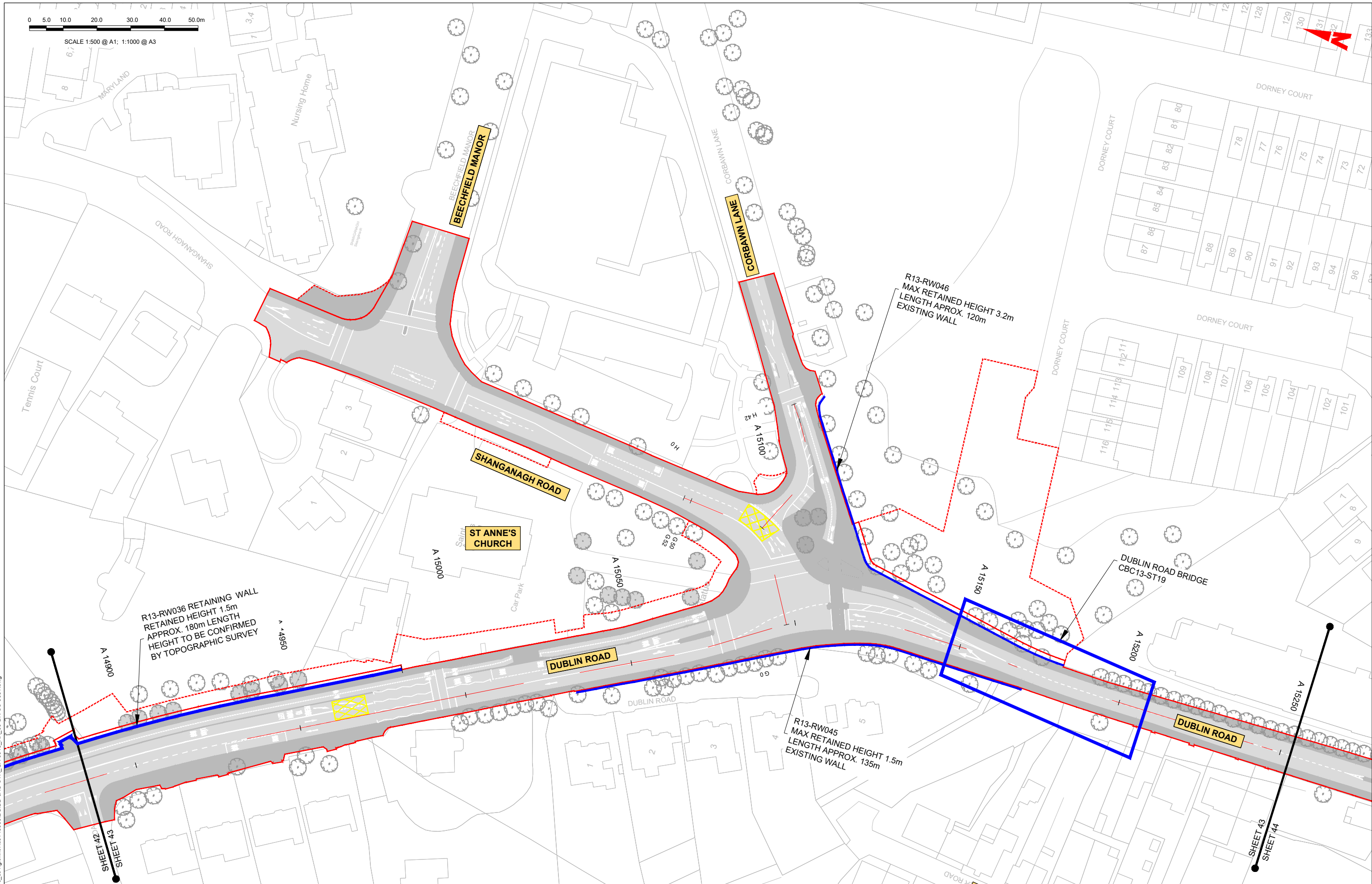

R13-RW036 RETAINING WALL
 RETAINED HEIGHT 1.5m
 APPROX. 180m LENGTH
 HEIGHT TO BE CONFIRMED
 BY TOPOGRAPHIC SURVEY

R13-RW046
 MAX RETAINED HEIGHT 3.2m
 LENGTH APPROX. 120m
 EXISTING WALL

R13-RW045
 MAX RETAINED HEIGHT 1.5m
 LENGTH APPROX. 135m
 EXISTING WALL

C:\pwworking\jacobs_uk_highways_ss4\glenmor0148698\BCIDB-JAC-STR_GA-0013_XX_00-DR-SS-0031.dwg

Disclaimer

a. © National Transport Authority (NTA) 2022. This drawing is confidential and the copyright in it is owned by NTA. This drawing must not be either loaned, copied or otherwise reproduced in whole or in part or used for any purpose without the prior permission of NTA.

b. This drawing is to be used for the design element identified in the titleblock. Other information shown is to be considered indicative only. The drawing is to be read in conjunction with all other relevant design drawings.

c. O.S. data used for plans are printed under © Ordnance Survey Ireland Government of Ireland. All rights reserved. Licence Number 2022/OS_NMA_180 National Transport Authority. All elevations are in metres and relate to OSi Geoid Model (OSGM15) Mean Head. All Co-ordinates are in Irish Transverse Mercator Grid (ITM) as defined by OSi active local GPS station.

d. Information concerning the position of apparatus shown on this drawing is based on drawings supplied by the utility owners and/or the utility works contractor, whilst every care has been taken in the preparation of this drawing, positions should be taken as approximate and are intended for general guidance only and no representation is made by the NTA as to the accuracy, completeness, sufficiency or otherwise of this drawing and the position of the apparatus. The information contained herein does not purport to be comprehensive or final as the apparatus is subject to being altered and/or superceded. Recipients should not rely on this information. Any liabilities are hereby expressly disclaimed.

e. The information contained herein has been provided by the NTA but does not purport to be comprehensive or final. Recipients should not rely on the information. Neither the NTA nor any of its directors, officers, employees, agents, stakeholders or advisers make any representation or warranty as to, or accept any liability or responsibility in relation to, the adequacy, accuracy, reasonableness or completeness of the information provided as part of this document or any matter on which the information is based (including but not limited to loss or damage arising as a result of reliance by recipients on the information or any part of it). Any liabilities are hereby expressly disclaimed.



Rev	Date	Drn	Chk'd	App'd	Description
M01	27/01/2023	RG	JM	RS	ISSUE FOR PHASE 4: PLANNING

Client: **NTA**
 Údarás Náisiúnta Iompair
 National Transport Authority

Engineering Designer: **Jacobs**

Date: 27/01/2023 | Scale: 1:500 @ A1, 1:1000 @ A3 | Drawn: RG | Checked: JM | Approved: RS

Project Code: BCIDB | Originator Code: JAC | QMS Code:

Programme Title: BUSCONNECTS DUBLIN CORE BUS CORRIDORS INFRASTRUCTURE WORKS			
Drawing Title: BRAY TO CITY CENTRE SCHEME STRUCTURES GENERAL ARRANGEMENT			
Drawing File Name: BCIDB-JAC-STR_GA-0013_XX_00-DR-SS-0043	Sheet Number: 43 of 54	Status: A	Rev: M01

DO NOT SCALE USE FIGURED DIMENSIONS ONLY

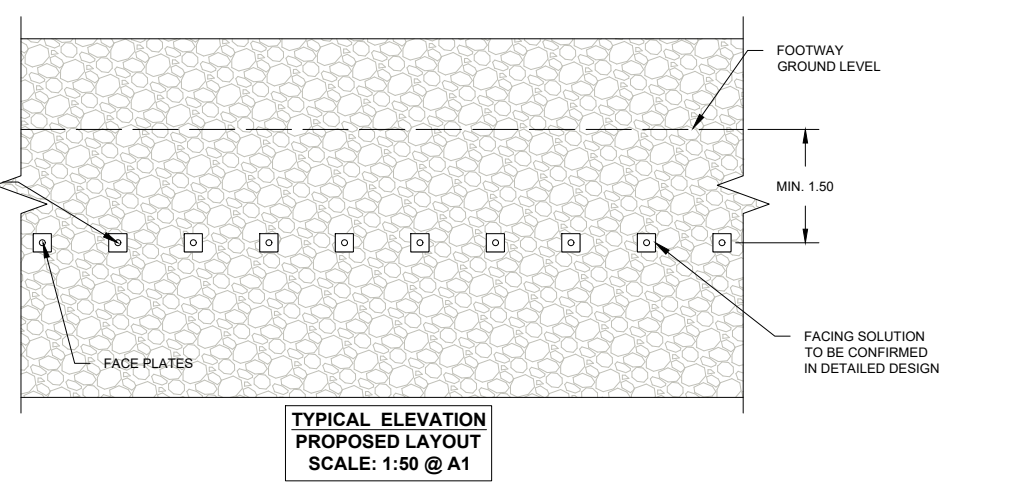
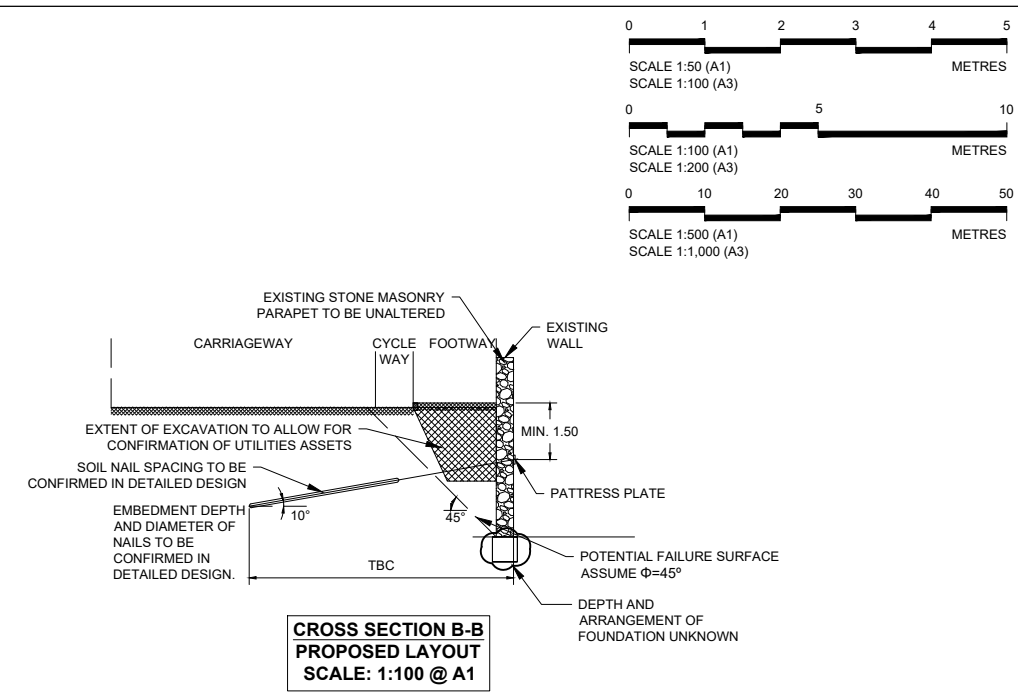
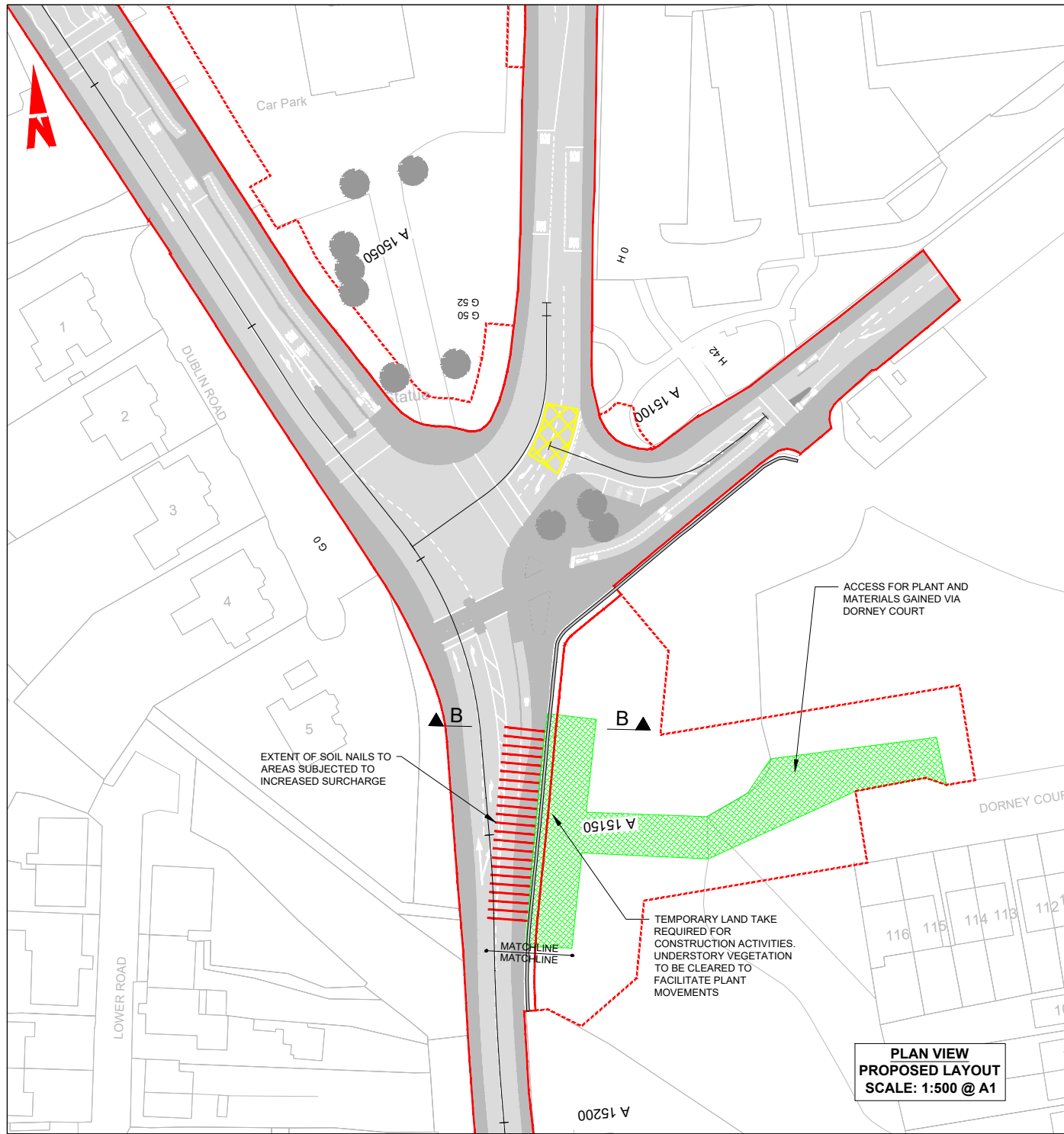

- NOTES:**
- ALL DIMENSIONS ARE SHOWN IN MILLIMETRES UNLESS NOTED OTHERWISE.
 - ALL LEVELS ARE SHOWN IN METRES ABOVE ORDINANCE OSi GEOID MODEL (OSGM15) MALIN HEAD.
 - FINISHES:
 - BURIED UNFORMED SURFACES -U1
 - BURIED FORMED SURFACES -F1
 - EXPOSED UNFORMED SURFACES (EXCLUDING AREA TO BE WATERPROOFED) -U3
 - ALL OTHER EXPOSED FORMED SURFACES -F4
 - MATERIALS:
 - LOCATION: RETAINING WALLS CONCRETE GRADE: -C32/40 (50% GGBS)
 - NON-STRUCTURAL CONCRETE: CONCRETE GRADE: -ST2
 - LOCATION: CONCRETE FOR BLINDING
 - BURIED CONCRETE SURFACES SHALL BE TREATED WITH TWO COATS OF EPOXY RESIN WATERPROOFING PAINT IN ACCORDANCE WITH TI CC-SPW-01700.

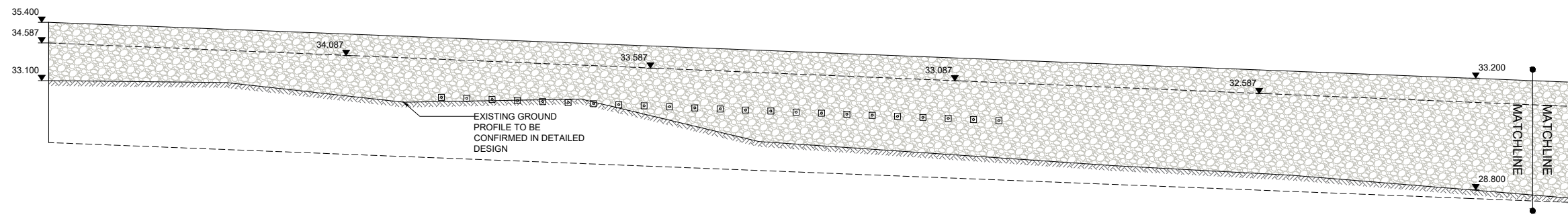

C:\pwworking\jacobs_uk_highways_ss4\glennor\d0148698\BCIDB-JAC-STR_GA-0013_RW_00-DR-CB-1110.dwg

Disclaimer:

a. © National Transport Authority (NTA) 2021. This drawing is confidential and the copyright in it is owned by NTA. This drawing must not be either loaned, copied or otherwise reproduced in whole or in part or used for any purpose without the prior permission of NTA.

b. This drawing is to be used for the design element identified in the titleblock. Other information shown is to be considered indicative only. The drawing is to be read in conjunction with all other relevant design drawings.

c. O.S. data used for plans are printed under © Ordnance Survey Ireland Government of Ireland. All rights reserved. Licence Number 2021/OS_NMA_180 National Transport Authority. All elevations are in metres and relate to OSi Geoid Model (OSGM15) Malin Head. All Co-ordinates are in Irish Transverse Mercator Grid (ITM) as defined by OSi active local GPS station.

d. Information concerning the position of apparatus shown on this drawing is based on drawings supplied by the utility owners and/or the utility works contractor, whilst every care has been taken in the preparation of this drawing, positions should be taken as approximate and are intended for general guidance only and no representation is made by the NTA as to the accuracy, completeness, sufficiency or otherwise of this drawing and the position of the apparatus. The information contained herein does not purport to be comprehensive or final as the apparatus is subject to being altered and/or superceded. Recipients should not rely on this information. Any liabilities are hereby expressly disclaimed.

e. The information contained herein has been provided by the NTA but does not purport to be comprehensive or final. Recipients should not rely on the information. Neither the NTA nor any of its directors, officers, employees, agents, stakeholders or advisers make any representation or warranty as to, or accept any liability or responsibility in relation to, the adequacy, accuracy, reasonableness or completeness of the information provided as part of this document or any matter on which the information is based (including but not limited to loss or damage arising as a result of reliance by recipients on the information or any part of it). Any liabilities are hereby expressly disclaimed.

Rev	Date	Drn	Chk'd	App'd	Description
M01	27/01/2023	RG	JM	RS	ISSUE FOR PHASE 4: PLANNING

Client: **NTA**
Údarás Náisiúnta Iompair
National Transport Authority

Engineering Designer: **Jacobs**

Date: 27/01/2023
Project Code: BCIDB
Originator Code: JAC

Scales shown @ A1 as shown @ A3
Drawn: RG
Checked: JM
Approved: RS

Programme Title: **BUSCONNECTS DUBLIN CORE BUS CORRIDORS INFRASTRUCTURE WORKS**

Drawing Title: BRAY TO CITY CENTRE SCHEME
DUN LAOGHAIRE RATHDOWN COUNTY COUNCIL
GENERAL ARRANGEMENT
R13-RW046

Drawing File Name: BCIDB-JAC-STR_GA-0013_RW_00-DR-CB-1110
Sheet Number: 01 of 1
Status: A
Rev: M01

DO NOT SCALE USE FIGURED DIMENSIONS ONLY

The background is a vibrant red color. It is decorated with several abstract geometric shapes: a large green semi-circle in the top-left corner; a blue semi-circle with a red border in the top-center; a blue vertical bar with a white circle in the top-right; a dark blue horizontal bar with a white circle in the middle-right; a blue horizontal bar with a white circle in the bottom-left; a dark blue horizontal bar with a white circle in the bottom-left; and a large green semi-circle in the bottom-right, partially overlapping a dark blue semi-circle and a red semi-circle, both with white borders.

Appendix F5
UCD Flyover
Record of Structural Review

© Copyright 2023 Jacobs Engineering Ireland Limited. The concepts and information contained in this document are the property of Jacobs. Use or copying of this document in whole or in part without the written permission of Jacobs constitutes an infringement of copyright.

Limitation: This document has been prepared on behalf of, and for the exclusive use of Jacobs' client, and is subject to, and issued in accordance with, the provisions of the contract between Jacobs and the client. Jacobs accepts no liability or responsibility whatsoever for, or in respect of, any use of, or reliance upon, this document by any third party.

Record of Structural Review Form			
Structure Details			
Structure Name	UCD Flyover		
Structure Number	DR-N11-010.00		
Date Commissioned	Circa 1971		
Obstacles Crossed	R138		
Bridges Carries	R138		
Brief Description of Structure			
Superstructure consists of a 4-span reinforced concrete pseudo-slab constituted of prestressed precast inverted T beams and in-situ infill with an in-situ reinforced concrete deck. Substructure consists of 3 No. piers per support supporting a capping beam. Reinforced concrete abutments are provided at both sides of the structure. Foundations consist of reinforced concrete pads.			
Elements to be Reviewed (where not the whole structure)			
Reason for Structural Review	Change to loading arrangement		
Existing Assessment Details or Design Records			
Inspection for Assessment Date	N/A	Recorded Condition	N/A
Technical Acceptance Report for Assessment	N/A	Status	N/A
Assessment Date	N/A	Report Number	N/A
Current Assessed/Design Capacity (include Reserve Factors)			
HA/ALL	N/A	SV	N/A
Critical Elements	N/A. No assessment available.		
Parapet	No Assessment available. Parapet type is Steel with rib infill. From initial review of historical drawings, parapets appear not to possess the containment level required by modern standards		
Pier Impact	Risk of pier impact has been mitigated with VRS system		
Certification	N/A		
Calculations	N/A		
As built drawings	As Built drawings dated April 1971, stored on Eirspan system		
Comments on Assessment or Design			
No recent assessment has been undertaken. Recent inspection by RPS for TII in 2012 found that the original construction quality was poor and has resulted in a number of defects. Parapet capacity is unknown but appear to be an insufficient containment level. Design carried out to previous standards.			
Evaluation			
Inspection Date	March 2012 (RPS for TII)		
Change in Condition	Areas of honeycombing to the underside of the cantilever at the eastern wingwall. Large crack to the eastern edge beam. North east abutment reinforcement protruding from concrete and corroded. Piers in generally poor condition areas of spalling with localised corrosion of reinforcement on significant number of piers (reinforcement cover noted as low). Honeycombing noted on western piers. Deck soffit in fair condition, small areas of spalling concrete and localised corrosion noted. It was noted that original construction quality was poor.		
Change in Standards	Design would have been undertaken in accordance with CP 114: Structural use of reinforced concrete in buildings and CP 116: structural use of precast concrete. Both standards' pre-date the introduction of the limit state partial safety factor approach and therefore are not directly comparable to modern standards.		

<p>Change in Loading</p>	<p>New highway alignment moves northbound traffic lanes further east on the bridge. Removal of central island and decrease in width of applied vehicular loading across structure. Refer to Appendix A for existing and proposed highway plans.</p> <table border="0"> <tr> <td>Existing cross section:</td> <td>Proposed cross section:</td> </tr> <tr> <td>West cope 0.4m</td> <td>West cope 0.4m</td> </tr> <tr> <td>West footway 3.2m</td> <td>West footway 3.7m</td> </tr> <tr> <td>West Carriageway 7.2m</td> <td>West Cycleway 3.0m</td> </tr> <tr> <td>Central Median 1.6m</td> <td>West Median 0.5m</td> </tr> <tr> <td>East Carriageway 7.2m</td> <td>West Bus lane 3.0m</td> </tr> <tr> <td>East footway 3m</td> <td>Carriageway 6.0m</td> </tr> <tr> <td>East cope 0.4m</td> <td>East Bus lane 3.0m</td> </tr> <tr> <td></td> <td>East footway 3.1m</td> </tr> <tr> <td></td> <td>East cope 0.4m</td> </tr> </table> <p>A preliminary analysis of the superstructure has been undertaken comparing loadings from the current and proposed alignments. This has been carried out using the loadings of AM-STR-06026 "<i>The Assessment of Road Bridges and Structures</i>".</p> <p>As the bridge forms the access to the University, it is considered unlikely that the structure will be subjected to abnormal loadings. Accordingly, HB loading and the SV / SOV loadings of AM-STR-06048, have not been considered at this stage.</p> <p>The preliminary analysis was carried out using a 2D grillage. The analysis resulted in the following conclusions:</p> <ul style="list-style-type: none"> - The longitudinal prestressed beams were subject to a 1% increase in bending from the revised alignment. - Stresses in the edge member under the proposed alignment are comparable to that produced from the existing arrangement. - The proposed alignment would result in a 1% increase in transverse bending near the bridge abutments. <p>Early analysis of the substructure comparing current loadings to proposed via hand calculations concluded the following:</p> <ul style="list-style-type: none"> - No significant change in foundation loading. <p>A comparison of load effects is included in Appendix B.</p> <p>The proposed alignment does not reduce footway widths and risk of impact to parapets is considered to be unchanged. A recent collision has occurred to the parapet on the North-Western approach and the parapet has been subject to local repair.</p> <p>A risk assessment was undertaken for the east parapet in accordance with DMRB CS46 1 Assessment and upgrading of in-service parapets. An as low as reasonably practical approach was adopted to assess the risk in accordance with the guidance provided in the document. As the bridge uses post 1967 socketed steel vertical rod infill parapets and the road is low speed the result of the risk assessment is that this arrangement is deemed to be very low risk and consequently requires no further intervention. . The highway authority may still consider the need for parapet replacement, or review to DN-REQ-03079</p>	Existing cross section:	Proposed cross section:	West cope 0.4m	West cope 0.4m	West footway 3.2m	West footway 3.7m	West Carriageway 7.2m	West Cycleway 3.0m	Central Median 1.6m	West Median 0.5m	East Carriageway 7.2m	West Bus lane 3.0m	East footway 3m	Carriageway 6.0m	East cope 0.4m	East Bus lane 3.0m		East footway 3.1m		East cope 0.4m
Existing cross section:	Proposed cross section:																				
West cope 0.4m	West cope 0.4m																				
West footway 3.2m	West footway 3.7m																				
West Carriageway 7.2m	West Cycleway 3.0m																				
Central Median 1.6m	West Median 0.5m																				
East Carriageway 7.2m	West Bus lane 3.0m																				
East footway 3m	Carriageway 6.0m																				
East cope 0.4m	East Bus lane 3.0m																				
	East footway 3.1m																				
	East cope 0.4m																				

	<p><i>"Design of Road Restraint System for Constrained Locations (Online Improvements, Retrofitting and Urban Settings), given the recent collision.</i></p> <p>A record of this risk assessment is included in Appendix C.</p>
<p>Conclusion</p>	<p>Defects in the structure have arisen due to poor construction quality, namely low cover resulting in reinforcement corrosion and subsequent concrete spalling. None of the identified defects appear to originate from overstressing of the structure so it can be concluded that the structure in its current arrangement is performing adequately with no signs of distress.</p> <p>It has been identified that the prestressed beams and transverse deck would both experience a small increase in bending in the order of 1% but this is not considered significant enough to warrant the intrusive investigations needed to confirm capacities.</p> <p>A risk assessment has been undertaken following DMRB CS461 to confirm the adequacy of the existing parapets and has concluded that no further intervention is required.</p>
<p>Recommendation</p>	
<p>The change in highway alignment will not have a detrimental impact on the bridge therefore no further structural investigations are required. Recommendations for on-site investigations as per the previous revision no longer apply.</p> <p>It should be noted that in accordance with AM-STR-06042 Annex A, as the structure was designed pre-1980, a full assessment would be required (separate from any need for assessment due to the proposed highway changes). Dún Laoghaire–Rathdown County Council may consider that such an assessment is required for continued use of the bridge. It is recommended that consideration is also given of the potential need for extensive investigation to confirm capacities, particularly of the prestressed beams. It may be prudent to continue to monitor the structure instead given the absence of any evidence of overstress from current loading.</p> <p>A risk assessment has been undertaken following DMRB CS461 to confirm the adequacy of the existing parapets. A further risk assessment following DN-REQ-03079 <i>"Design of Road Restraint System for Constrained Locations (Online Improvements, Retrofitting and Urban Settings)"</i>, may also be considered appropriate given the history of recent collisions.</p>	

THE ABOVE IS SUBMITTED FOR ACCEPTANCE

Signed¹

 _____

Name

_John McElhinney_____

Position

Lead Structural Engineer

Signed

 _____

Name

_Stuart Nicol_____

Position

Principal Officer or Director – Design Office

Date

01/02/21

ACCEPTANCE OF REVIEW FORM

The Technical Approval Authority accepts this certificate

Signed

Name

Position

Organisation

Date

//_

1. The persons who sign as Lead Structural Assessment Engineer must be a Chartered Engineer with a recognised University degree to Level 8 or equivalent with a minimum of 10 years post graduate experience in the assessment of bridge structures

Appendix A – Plan Arrangement

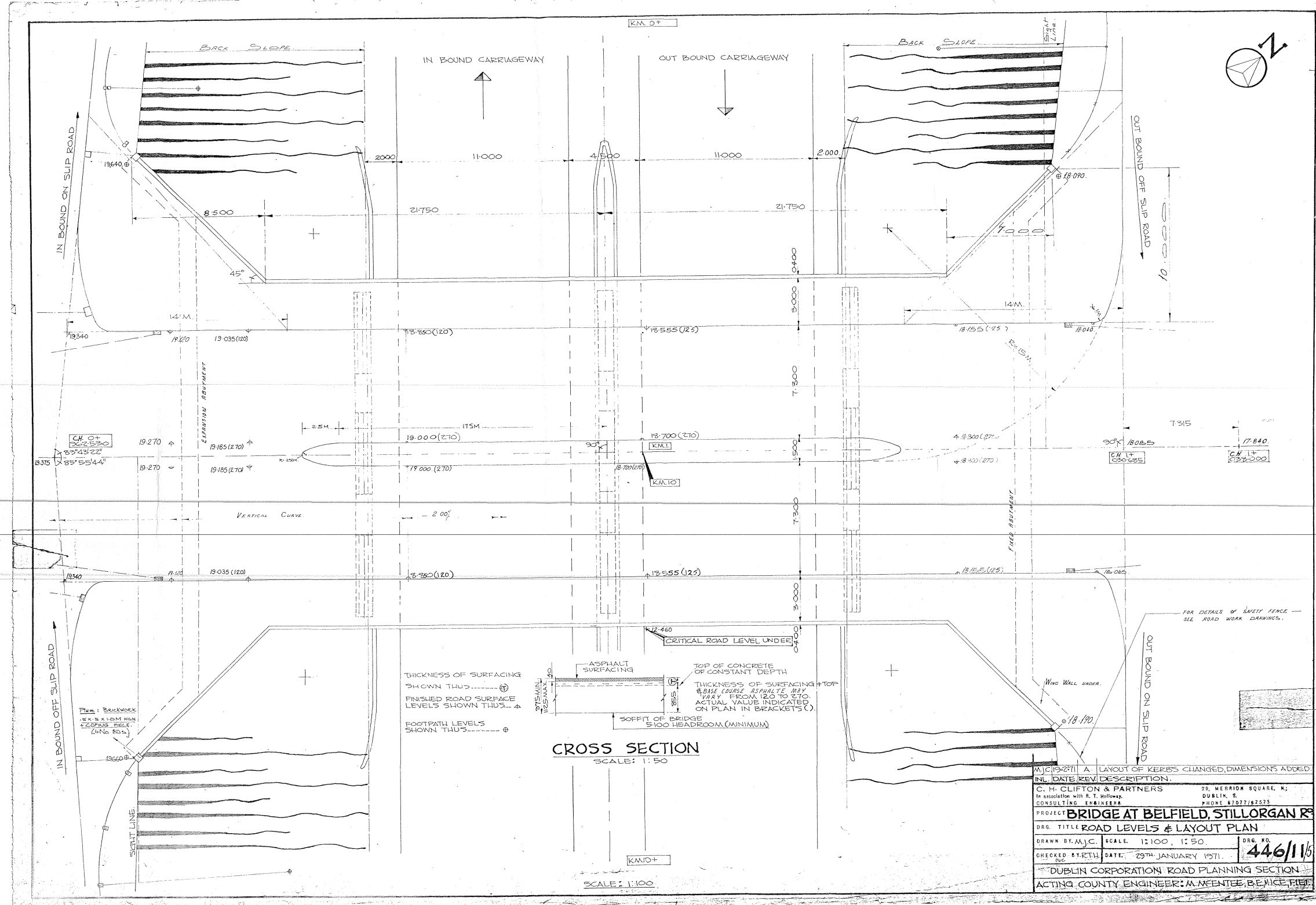

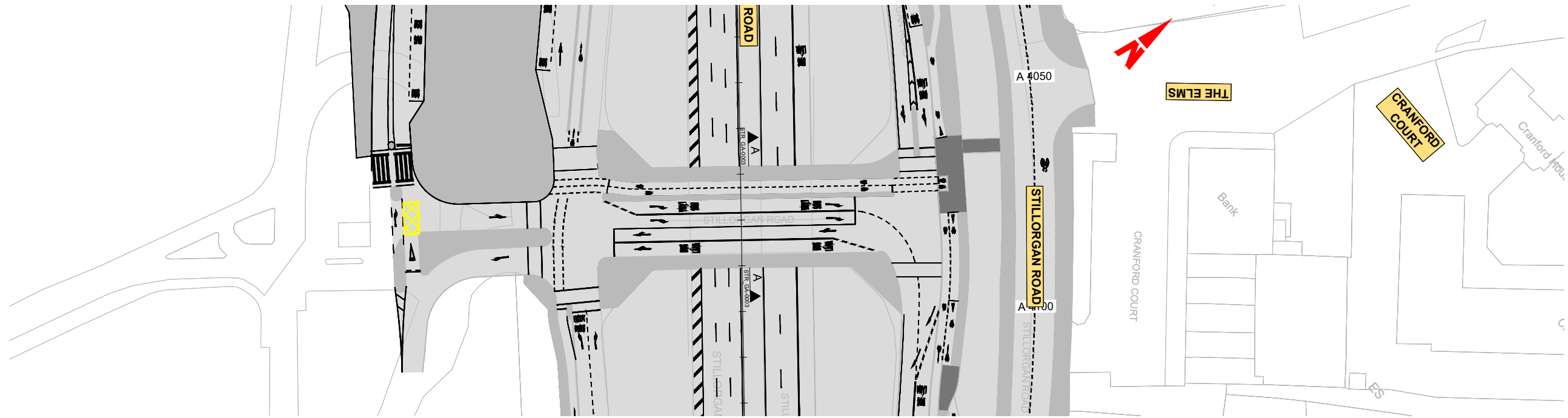

PLAN
(SCALE 1 : 500)

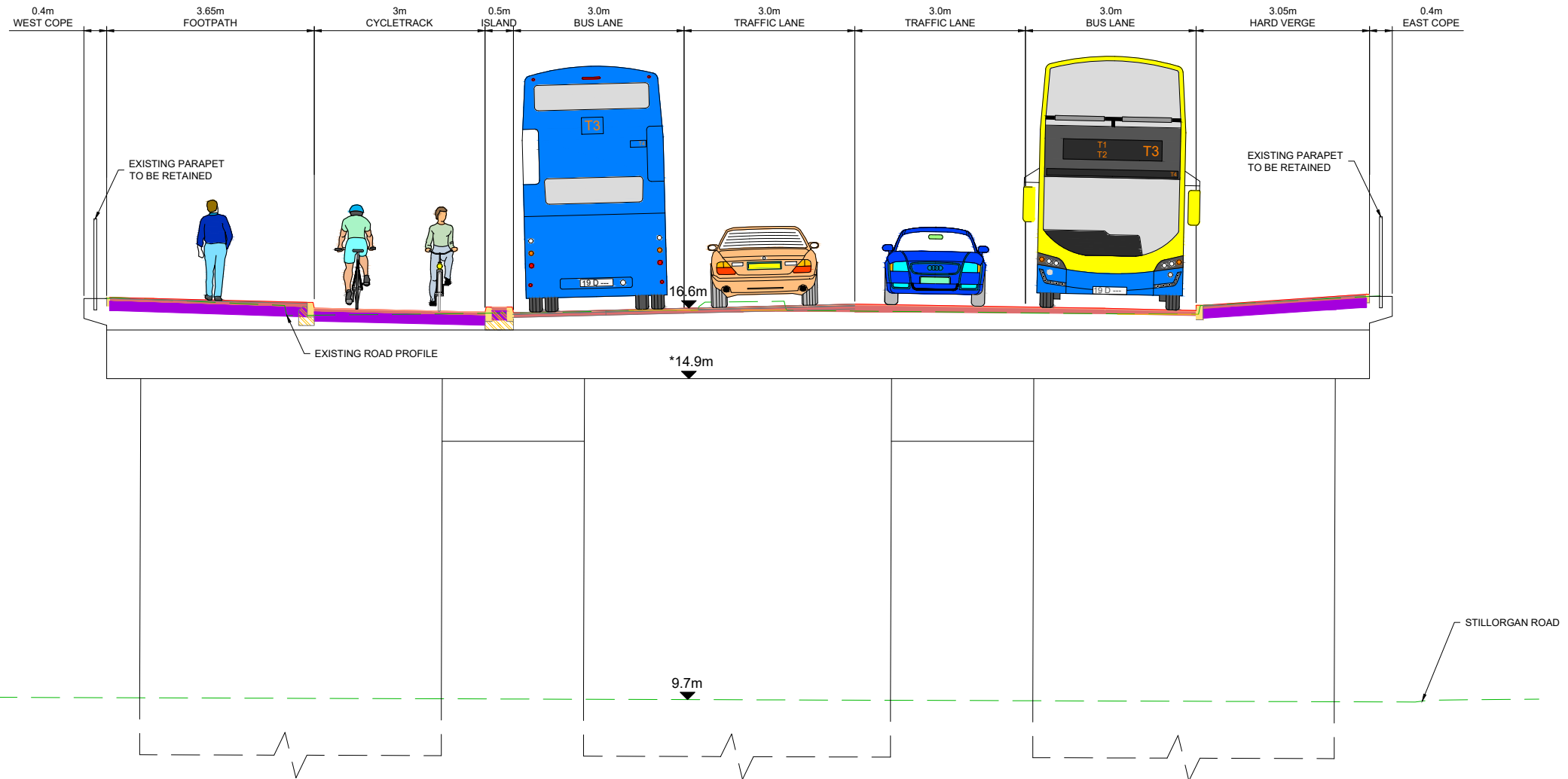

TYPICAL SECTION A-A
(SCALE 1 : 50)

- NOTES :**
1. ALL DIMENSIONS ARE SHOWN IN METRES UNLESS NOTED OTHERWISE.
 2. ALL LEVELS ARE REFERRED TO ORDNANCE SURVEY DATUM, MALIN HEAD.
 3. THIS DRAWING IS ONLY TO BE USED FOR THE DESIGN ELEMENT IDENTIFIED IN THE TITLE BOX. ALL OTHER INFORMATION SHOWN ON THE DRAWING IS TO BE CONSIDERED INDICATIVE ONLY.
 4. THESE DRAWINGS ARE TO BE READ IN CONJUNCTION WITH ALL OTHER RELEVANT DESIGN DRAWINGS.
 5. LEVELS DENOTED WITH * HAVE BEEN OBTAINED FROM HISTORIC INSPECTIONS AND CONSEQUENTLY POSSESS SOME LEVEL OF UNCERTAINTY.

C:\pwworking\jacobs_uk_highways\ss4\legintl_ds073624\016882\BCIDB-JAC-STR_GA-0013_BR_00-SK-CB-0003.dwg

Disclaimer

a. © National Transport Authority (NTA) 2020. This drawing is confidential and the copyright in it is owned by NTA. This drawing must not be either loaned, copied or otherwise reproduced in whole or in part or used for any purpose without the prior permission of NTA.

b. This drawing is to be used for the design element identified in the titlebox. Other information shown is to be considered indicative only. The drawing is to be read in conjunction with all other relevant design drawings.

c. O.S. data used for plans are printed under © Ordnance Survey Ireland Government of Ireland. All rights reserved. Licence Number 2020/OS_NMA_180 National Transport Authority. All elevations are in metres and relate to OSI Good Model (OSGM15) Malin Head. All Co-ordinates are in Irish Transverse Mercator Grid (ITM) as defined by OSI active local GPS station.

d. Information concerning the position of apparatus shown on this drawing is based on drawings supplied by the utility owners and/or the utility works contractor, whilst every care has been taken in the preparation of this drawing, positions should be taken as approximate and are intended for general guidance only and no representation is made by the NTA as to the accuracy, completeness, sufficiency or otherwise of this drawing and the position of the apparatus. The information contained herein does not purport to be comprehensive or final as the apparatus is subject to being altered and/or superseded. Recipients should not rely on this information. Any liabilities are hereby expressly disclaimed.

e. The information contained herein has been provided by the NTA but does not purport to be comprehensive or final. Recipients should not rely on the information. Neither the NTA nor any of its directors, officers, employees, agents, stakeholders or advisers make any representation or warranty as to, or accept any liability or responsibility in relation to, the adequacy, accuracy, reasonableness or completeness of the information provided as part of this document or any matter on which the information is based (including but not limited to loss or damage arising as a result of reliance by recipients on the information or any part of it). Any liabilities are hereby expressly disclaimed.



Rev	Date	Drn	Chk'd	App'd	Description
M01	27/01/2023	DS	RG	JM	PHASE 4: ISSUE FOR PLANNING

Date	27/01/2023	Drawn	DS	Checked	RG	Approved	JM
Project Code	BCIDB	Originator Code	JAC	QMS Code			

Programme Title BUSCONNECTS DUBLIN CORE BUS CORRIDORS INFRASTRUCTURE WORKS			
Drawing Title CBC 13 BRAY TO CITY CENTRE UCD FLYOVER PROPOSED CROSS SECTION			
Drawing File Name	BCIDB-JAC-STR_GA-0013_BR_00-SK-CB-0003	Sheet Number	01 of 01
Status	A	Rev	M01

DO NOT SCALE USE FIGURED DIMENSIONS ONLY

Appendix B – Summary of Load Effects

OFFICE	Bristol - Temple Quay	CALCS Ref		PAGE No.	1
JOB No. & TITLE	32110900 BusConnects Dublin - CBC 13 Bray to City Centre	ORIGINATOR	DS	DATE	21/01/2021
SECTION	UCD Flyover Comparison of Load Effects	CHECKER	RG	DATE	21/01/2021

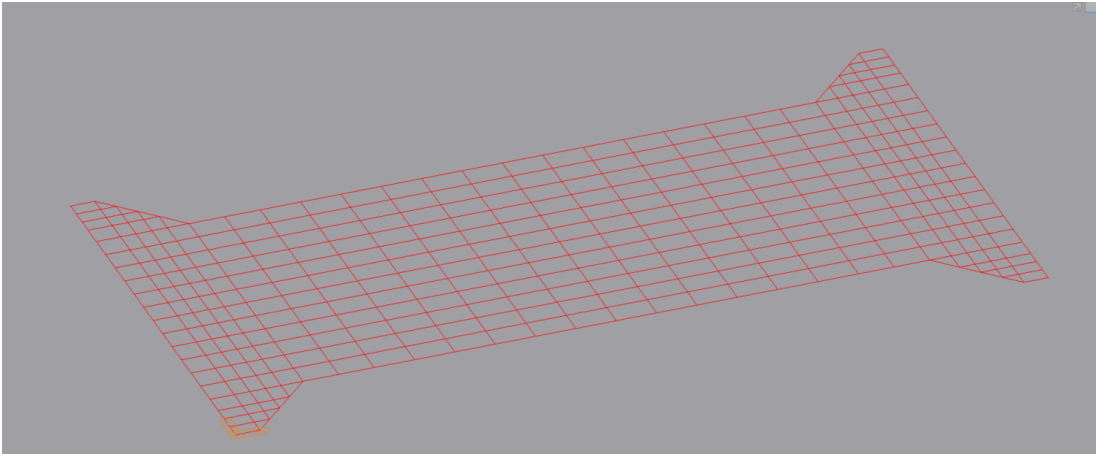
REF					TOTALS																																																																																
	<p><u>Introduction</u></p> <p>A comparative assessment was undertaken for UCD flyover comparing the existing arrangement over the bridge to the proposed. This was carried out using a 2D grillage in the FEA software MIDAS. An image of the idealised arrangement can be seen below. Load envelopes were taken such that the maximum load effects from HA and Accidental wheel loading was considered.</p> 																																																																																				
	<p><u>Longitudinal Prestressed Beams</u></p> <table border="1" style="width: 100%; border-collapse: collapse;"> <tr> <td style="width: 25%;">Max Bending Moment</td> <td style="width: 25%;">Existing (kNm)</td> <td style="width: 25%;">Proposed (kNm)</td> <td style="width: 25%;">% Change</td> </tr> <tr> <td></td> <td style="text-align: center;">1352.66</td> <td style="text-align: center;">1361.33</td> <td style="text-align: center;">1%</td> </tr> <tr> <td>Min Bending Moment</td> <td>Existing (kNm)</td> <td>Proposed (kNm)</td> <td>% Change</td> </tr> <tr> <td></td> <td style="text-align: center;">-2367.38</td> <td style="text-align: center;">-2345.05</td> <td style="text-align: center;">-1%</td> </tr> <tr> <td>Max Shear Force</td> <td>Existing (kN)</td> <td>Proposed (kN)</td> <td>% Change</td> </tr> <tr> <td></td> <td style="text-align: center;">860.49</td> <td style="text-align: center;">846.02</td> <td style="text-align: center;">-2%</td> </tr> <tr> <td>Min Shear Force</td> <td>Existing (kN)</td> <td>Proposed (kN)</td> <td>% Change</td> </tr> <tr> <td></td> <td style="text-align: center;">-860.62</td> <td style="text-align: center;">-846.04</td> <td style="text-align: center;">-2%</td> </tr> <tr> <td>Max Torsion</td> <td>Existing (kNm)</td> <td>Proposed (kNm)</td> <td>% Change</td> </tr> <tr> <td></td> <td style="text-align: center;">157.89</td> <td style="text-align: center;">156.47</td> <td style="text-align: center;">-1%</td> </tr> <tr> <td>Min Torsion</td> <td>Existing (kNm)</td> <td>Proposed (kNm)</td> <td>% Change</td> </tr> <tr> <td></td> <td style="text-align: center;">-157.23</td> <td style="text-align: center;">-155.8</td> <td style="text-align: center;">-1%</td> </tr> </table> <p>Therefore, there are no significant increases in the load effects of the longitudinal prestressed elements .</p> <p><u>In-situ Edge Member</u></p> <table border="1" style="width: 100%; border-collapse: collapse;"> <tr> <td style="width: 25%;">Max Bending Moment</td> <td style="width: 25%;">Existing (kNm)</td> <td style="width: 25%;">Proposed (kNm)</td> <td style="width: 25%;">% Change</td> </tr> <tr> <td></td> <td style="text-align: center;">1179.23</td> <td style="text-align: center;">1179.14</td> <td style="text-align: center;">0%</td> </tr> <tr> <td>Min Bending Moment</td> <td>Existing (kNm)</td> <td>Proposed (kNm)</td> <td>% Change</td> </tr> <tr> <td></td> <td style="text-align: center;">-2160.93</td> <td style="text-align: center;">-2140.87</td> <td style="text-align: center;">-1%</td> </tr> <tr> <td>Max Shear Force</td> <td>Existing (kN)</td> <td>Proposed (kN)</td> <td>% Change</td> </tr> <tr> <td></td> <td style="text-align: center;">818.89</td> <td style="text-align: center;">809.25</td> <td style="text-align: center;">-1%</td> </tr> <tr> <td>Min Shear Force</td> <td>Existing (kN)</td> <td>Proposed (kN)</td> <td>% Change</td> </tr> <tr> <td></td> <td style="text-align: center;">-819.11</td> <td style="text-align: center;">-809.25</td> <td style="text-align: center;">-1%</td> </tr> </table>				Max Bending Moment	Existing (kNm)	Proposed (kNm)	% Change		1352.66	1361.33	1%	Min Bending Moment	Existing (kNm)	Proposed (kNm)	% Change		-2367.38	-2345.05	-1%	Max Shear Force	Existing (kN)	Proposed (kN)	% Change		860.49	846.02	-2%	Min Shear Force	Existing (kN)	Proposed (kN)	% Change		-860.62	-846.04	-2%	Max Torsion	Existing (kNm)	Proposed (kNm)	% Change		157.89	156.47	-1%	Min Torsion	Existing (kNm)	Proposed (kNm)	% Change		-157.23	-155.8	-1%	Max Bending Moment	Existing (kNm)	Proposed (kNm)	% Change		1179.23	1179.14	0%	Min Bending Moment	Existing (kNm)	Proposed (kNm)	% Change		-2160.93	-2140.87	-1%	Max Shear Force	Existing (kN)	Proposed (kN)	% Change		818.89	809.25	-1%	Min Shear Force	Existing (kN)	Proposed (kN)	% Change		-819.11	-809.25	-1%	
Max Bending Moment	Existing (kNm)	Proposed (kNm)	% Change																																																																																		
	1352.66	1361.33	1%																																																																																		
Min Bending Moment	Existing (kNm)	Proposed (kNm)	% Change																																																																																		
	-2367.38	-2345.05	-1%																																																																																		
Max Shear Force	Existing (kN)	Proposed (kN)	% Change																																																																																		
	860.49	846.02	-2%																																																																																		
Min Shear Force	Existing (kN)	Proposed (kN)	% Change																																																																																		
	-860.62	-846.04	-2%																																																																																		
Max Torsion	Existing (kNm)	Proposed (kNm)	% Change																																																																																		
	157.89	156.47	-1%																																																																																		
Min Torsion	Existing (kNm)	Proposed (kNm)	% Change																																																																																		
	-157.23	-155.8	-1%																																																																																		
Max Bending Moment	Existing (kNm)	Proposed (kNm)	% Change																																																																																		
	1179.23	1179.14	0%																																																																																		
Min Bending Moment	Existing (kNm)	Proposed (kNm)	% Change																																																																																		
	-2160.93	-2140.87	-1%																																																																																		
Max Shear Force	Existing (kN)	Proposed (kN)	% Change																																																																																		
	818.89	809.25	-1%																																																																																		
Min Shear Force	Existing (kN)	Proposed (kN)	% Change																																																																																		
	-819.11	-809.25	-1%																																																																																		

OFFICE	Bristol - Temple Quay	CALCS Ref	0	PAGE No.	2
JOB No. & TITLE	32110900 BusConnects Dublin - CBC 13 Bray to City Centre	ORIGINATOR	DS	DATE	21/01/2021
SECTION	UCD Flyover Comparison of Load Effects	CHECKER	RG	DATE	21/01/2021

REF				TOTALS
Max Torsion	Existing (kNm)	Proposed (kNm)	% Change	
	151.07	150.5	0%	
Min Torsion	Existing (kNm)	Proposed (kNm)	% Change	
	-150.48	-149.91	0%	
Therefore, there are no increases in the load effects in the edge member.				
<u>In-situ Transverse Member</u>				
Max Bending Moment	Existing (kNm)	Proposed (kNm)	% Change	
	78.16	77.72	-1%	
Min Bending Moment	Existing (kNm)	Proposed (kNm)	% Change	
	-218.06	-219.18	1%	
Max Shear Force	Existing (kN)	Proposed (kN)	% Change	
	212.32	205.92	-3%	
Min Shear Force	Existing (kN)	Proposed (kN)	% Change	
	-443.85	-444.28	0%	
Max Torsion	Existing (kNm)	Proposed (kNm)	% Change	
	155.95	155.89	0%	
Min Torsion	Existing (kNm)	Proposed (kNm)	% Change	
	-156.44	-156.38	0%	
Therefore, there are no significant increases in the load effects in in-situ transverse members.				

Appendix C – Parapet Risk Assessment

OFFICE	Bristol - Temple Quay	CALCS Ref		PAGE No.	1
JOB No. & TITLE	32110900 BusConnects Dublin - CBC 13 Bray to City Centre	ORIGINATOR	DS	DATE	19/01/2021
SECTION	UCD Flyover Parapet Assessment	CHECKER	RG	DATE	19/01/2021

REF		TOTALS
-----	--	--------

Risk Assessment for In-service Parapet

This assessment shall adopt the ALARP approach in accordance with DRMB publication CS 461 Assessment and upgrading of in-service parapets. No equivalent publication was found in the TII library, but the principles adopted by CS 461 should be transferable to an Irish scheme.

Existing parapet consists of a steel vertical rod infill parapet with steel socketed connections to the edge member as shown below.

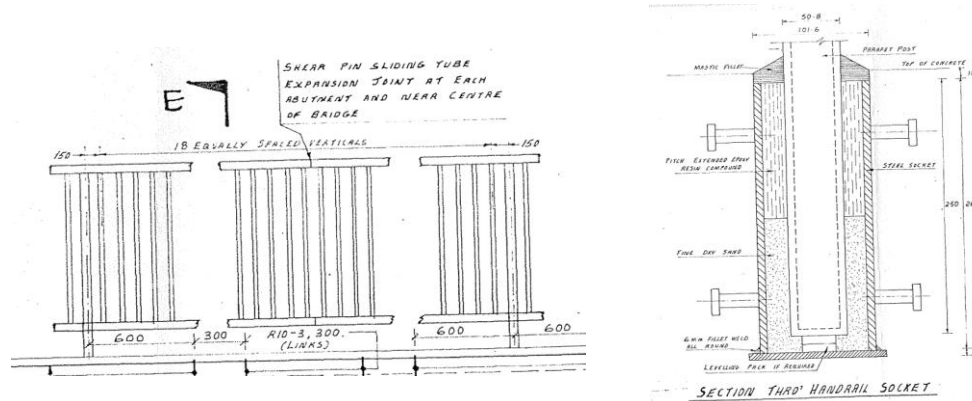

The road carried by the UCD bridge is a short access road for the university and forms part of a junction for the N11. As such traffic speeds over the structure will be low. The speeds on the N11 below the structure is 80 kmph.

CS 461 Table 3.6 Allowable resistance of parapet, $C_{ALL} = 0.134 N2$ For a 30mph road.

CS 461 Table 3.7 Minimum resistance, $C_{min} = 0.15 N2$

As the parapet supports comprise of post 1967 socket connections they are deemed as adequate.

The existing parapets can be assumed to have the following remnant resistance.

CS 461 cl 4.19 Effective remnant containment resistance, $R_{cont} = 0.33 N2$

ALARP based risk score

$$R_{ALARP} = \frac{AADT \cdot F_1 \cdot F_2 \cdot F_3}{10000}$$

CS 461 Table A.1 Average two way daily traffic flow, $AADT = 7000$

CS 461 Table A.2 Required containment resistance, $C_{REQ} = 0.2$

Remnant resistance, R_{cont} (as a % of required containment resistance, C_{REQ}) = 60.61%

CS 461 Table A.3 Parapet containment factor, $F_1 = 1$

Clearance to permanent traffic face under new alignment = 3.1 m

CS 461 Table A.4 Site features factor, $F_2 = 0.975$

CS 461 Table A.5 Ease of upgrading factor, $F_3 = 1$ Conservative assumption.

ALARP based risk score, $R_{ALARP} = 0.6825$

OFFICE	Bristol - Temple Quay	CALCS Ref		PAGE No.	2
JOB No. & TITLE	32110900 BusConnects Dublin - CBC 13 Bray to City Centre	ORIGINATOR	DS	DATE	19/01/2021
SECTION	UCD Flyover Parapet Assessment	CHECKER	RG	DATE	19/01/2021

REF		TOTALS
-----	--	--------

CS 461 Appendix B

Incursion Risk

Factors	Score
f1: Road approach containment on upper road	1
f2: Upper road alignment (horizontal)	1
f3: Upper road alignment (vertical)	1
f4: Actual speed of approaching road traffic on upper road	3
f5: Site topography	6
f6: Site specific hazards increasing risk of RTA on upper road	5
f7: Site specific hazards increasing risk of RTA on upper road and road below	1
f8: Vehicle parapet resilience on upper road	2
f9: Upper road verges and footpaths	2
f10: Upper road signage and markings	1
f11: Volume of traffic on upper road	2
f12: Actual speed of traffic on lower road	12
f13: Site specific hazards increasing consequence of event on lower road	5
f14: Combined volume of traffic on lower road	11
R_{Inc}	53

Figure 3.8a Assessment flowchart - bridges over roads

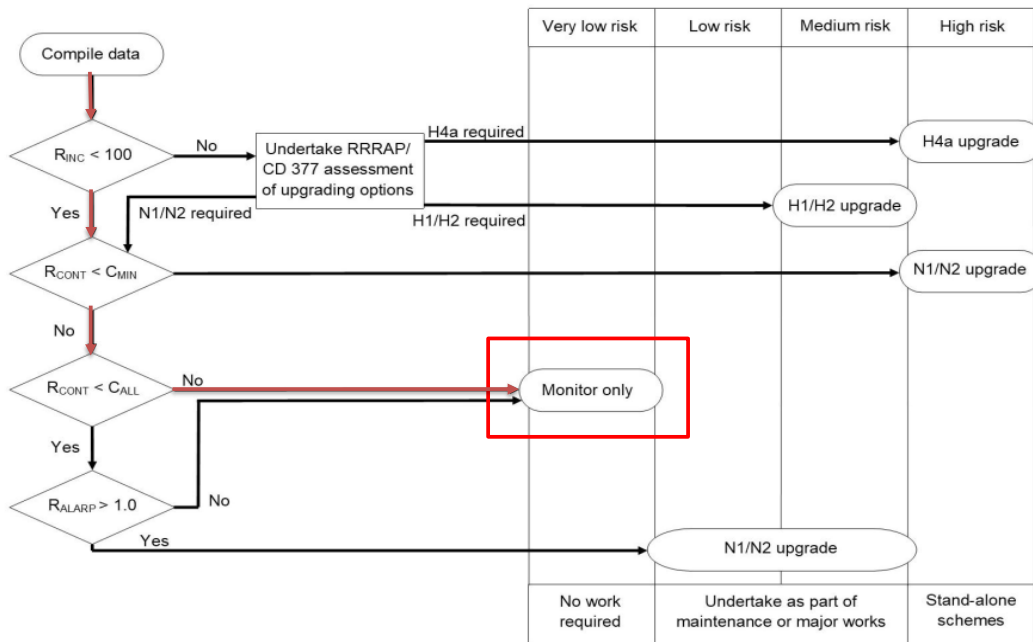

CS 461 Revision 0
3. Risk assessment of existing parapet sites and

Following the above flowchart it can be seen that the parapet is classified as very low risk and no intervention is required.



Appendix F6
St Columcille Footbridge
Record of Structural Review

© Copyright 2023 Jacobs Engineering Ireland Limited. The concepts and information contained in this document are the property of Jacobs. Use or copying of this document in whole or in part without the written permission of Jacobs constitutes an infringement of copyright.

Limitation: This document has been prepared on behalf of, and for the exclusive use of Jacobs' client, and is subject to, and issued in accordance with, the provisions of the contract between Jacobs and the client. Jacobs accepts no liability or responsibility whatsoever for, or in respect of, any use of, or reliance upon, this document by any third party.

TRANSPORT INFRASTRUCTURE IRELAND			
Record of Structural Review Form			
Structure Details			
Structure Name	St Columcille Footbridge		
Structure Number	DR-N11-001.00		
Date Commissioned	Circa 1991		
Obstacles Crossed	N11		
Bridges Carries	Pedestrian footway		
Brief Description of Structure			
Bridge superstructure consists of 3 No. spans. The 29m main central span is constructed of a post-tensioned concrete beam of varying depth formed as a half joint construction. Approach ramps consist of 9 No. spans comprised of in situ reinforced concrete beams supported on reinforced concrete piers and abutments. The substructure comprises of reinforced concrete spread footings.			
Elements to be Reviewed (where not the whole structure)			
Clearance to pier and bridge soffit due to proposed highway alignment changes.			
Reason for Structural Review	Change to highway alignment below structure.		
Existing Assessment Details or Design Records			
Inspection for Assessment Date	N/A	Recorded Condition	N/A
Technical Acceptance Report for Assessment	N/A	Status	N/A
Assessment Date	N/A	Report Number	N/A
Current Assessed/Design Capacity (include Reserve Factors)			
HA/ALL	N/A	SV	N/A
Critical Elements	N/A		
Parapet	N/A		
Pier Impact	N/A. Risk of pier impact has been mitigated with VRS		
Certification	N/A		
Calculations	N/A		
As built drawings	Construction drawings dated April-July 1991		
Comments on Assessment or Design			
No assessment has been undertaken. Recent inspection by Atkins in November 2020 concluded that the original design appears to be performing adequately albeit minor defects were noted. Design carried out to BS 5400.			
Evaluation			
Inspection Date	23 rd November 2020 (Atkins)		
Change in Condition	<p>Findings from inspection by Atkins were as follows: <i>Half-joints and the north west wing wall were noted to be leaking. Minor hairline cracks were noted on parapet edge beams. The rest of the structure including piers and abutments was found in good condition.</i></p> <p>The proposed highway alignment results in a reduction in the width of the central median, and the shift of the southbound kerb line to the west away from the bridge pier. Refer to Appendix A for existing and proposed highway plans.</p>		

Existing cross section:

West Footway	2.4m (located west of the west pier)
West Cycle Lane	2.7m (located west of the west pier)
West Verge	5.2m total, 4.6m between pier face & kerb line
West Carriageway	7.3m
Central Median	4.4m
East Carriageway	7.3m
East Verge	6.7m total, 4.8m between pier face & kerb line
East Cycle Lane	3.3m (located east of the east pier)
East Footway	3.0m (located east of the east pier)

Proposed cross section:

West Footway	2.0m (located west of the west pier)
West Cycle Lane	2.0m (located west of the west pier)
West Verge	6.3m total, 4.6m between pier face & kerb line
West Carriageway	7.2m
Central Median	1.2m
East Carriageway	6.5m
East Bus Lane	3.2m
East Verge	7.2m total, 5.5m between pier face & kerb line
East Cycle Lane	2.5m (located east of the east pier)
East Footway	2.0m (located east of the east pier)

The current and proposed alignments were checked to determine if the carriageway was positioned adequately to prevent the likelihood of accidental loading from errant vehicles on the piers. The west kerb line will remain at 4.6m from the west pier face, while the east kerb line will be moved 0.7m towards the central median from 4.8m to 5.5m from the east pier face. Therefore, both carriageway alignments comply with the minimum distance of 4.5m, in accordance with AM-STR-06032 *"The Assessment and Strengthening of Road Bridge Supports"*, and there is no requirement for assessment to consider an errant vehicle impacting the piers.

A geometric assessment to check the proposed cross section and clearance under the bridge was undertaken so that potential errant vehicles do not strike the superstructure. It was assumed the existing vehicle restraint system (VRS) has a working width of 0.8m. The existing VRS by the east carriageway is located 1.85m from the kerb line which gives a clearance of 4.77m due to the existing 3.3:1 gradient verge slope on which the maximum extent of the envelope lies. A headroom of 5.41m is required, in accordance with DN-GEO-03036 *"Cross Sections and Headroom"* therefore, the existing arrangement is substandard. The existing VRS by the west carriageway is located 1.2m from the kerb line and assuming a W2 (0.8m) working width provides 5.35m vertical clearance at the back of the working width. Therefore, in its current arrangement the headroom provided at the west of the structure is also substandard.

The proposed alignment moves the face of traffic 0.7m away from the east pier and includes the introduction of a W1 VRS barrier and a local regrading of the verge. The proposed alignment will provide the required clearance to the back of the VRS working width, complying with DN-GEO-03036 Section 6.2e. There

	is no proposed modification to the east carriageway as part of the BusConnects scheme.
Change in Standards	This structural review has not been prepared in response to a change in standards.
Change in Loading	This structural review has not been prepared in response to a change in loading.
Conclusion	<p>The bridge is currently in good condition and is performing adequately with no signs of distress.</p> <p>The existing arrangement possesses a substandard vertical clearance at the east verge and without further intervention the proposed alignment would also result in a substandard vertical clearance. The existing arrangement on the west verge results in a substandard headroom at the back of the assumed existing working width. There is no proposed works to the west verge as part of the BusConnects scheme.</p> <p>The proposed alignment moves the face of traffic 0.7m away from the east pier and includes the introduction of a W1 VRS barrier and a local regrading of the verge. The proposed alignment will provide the required clearance to the back of the VRS working width, complying with DN-GEO-03036 Section 6.2e. This is an improvement on the vertical clearance to the existing structure.</p> <p>The proposed highway alignment provides a horizontal clearance to the bridge piers in excess of minimum distance of 4.5m, in accordance with AM-STR-06032 "<i>The Assessment and Strengthening of Road Bridge Supports</i>". Therefore, there is no requirement to consider an errant vehicle impacting the piers and no further mitigation is required.</p> <p>Although the existing arrangement is considered substandard at the west verge there are no proposed impacts to this location resulting from the scheme. Therefore, this aspect of the structure is not considered to be within the scope of the works and no intervention is required.</p>
Recommendation	
<p>Measures to achieve the required headroom should be undertaken through the introduction of a VRS, with a W1 working width (0.6m) positioned 0.65m from the face of traffic in the southbound carriageway. The verge should also be levelled to the back of the VRS working width and regraded up to the east pier face such that there is no risk of damage to the pier waterproofing. This results in a headroom of 5.46m at the back of the working width of the VRS which is compliant with the requirements of DN-GEO-03036 Section 6.2e. Works to regrade the verge would not impact bridge foundations, which lie approximately 2.4m below the carriageway level based on historical drawings, or underground utilities.</p> <p>The proposed highway alignment and the measures set out above will mitigate the risk of accidental collision loading to the bridge therefore, no further structural assessment is required. However, this should be confirmed during the detailed design phase with a more detailed survey of the footbridge location to confirm soffit levels and existing / proposed carriageway levels under the bridge.</p> <p>Although, works to the west verge are not considered as part of the scope of the BusConnects scheme the TII may wish to consider upgrading the VRS at this location in a similar manner as proposed for the east verge to improve the function of the structure.</p>	

THE ABOVE IS SUBMITTED FOR ACCEPTANCE

Signed¹



Name John McElhinney
Position Lead Structural Engineer

Signed



Name Stuart Nicol
Position Principal Officer or Director – Design Office

Date 22/02/2021

ACCEPTANCE OF REVIEW FORM

Transport Infrastructure Ireland accepts this certificate

Signed

Name

Position

Structures, Transport Infrastructure Ireland

Date

___ / ___ / ___

1. The persons who sign as Lead Structural Assessment Engineer must be a Chartered Engineer with a recognised University degree to Level 8 or equivalent with a minimum of 10 years post graduate experience in the assessment of bridge structures

Appendix A – General Arrangement



**PLAN - ST COLUMCILLE FOOTBRIDGE LOCATION
PROPOSED HIGHWAY ALIGNMENT
SCALE: 1:200 @ A1**

LEGEND:

	BUS LANE
	CYCLE TRACK
	FOOTPATH
	CARRIAGEWAY
	GRASS AREA / VERGE

© Ordnance Survey Ireland Government of Ireland. All rights reserved.
Licence Number EN 0082119 National Transport Authority.

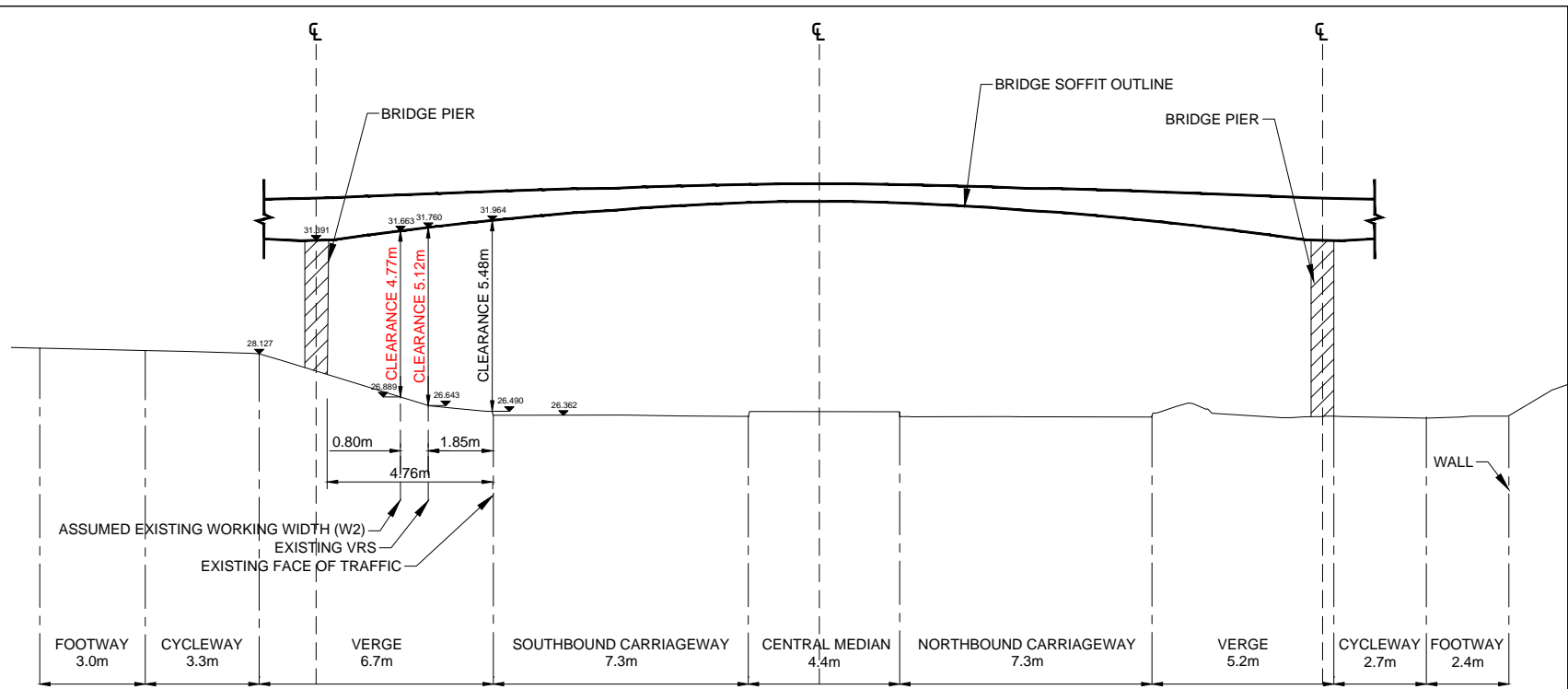

**CROSS SECTION - AA
EXISTING LAYOUT
SCALE: 1:100 @ A1**

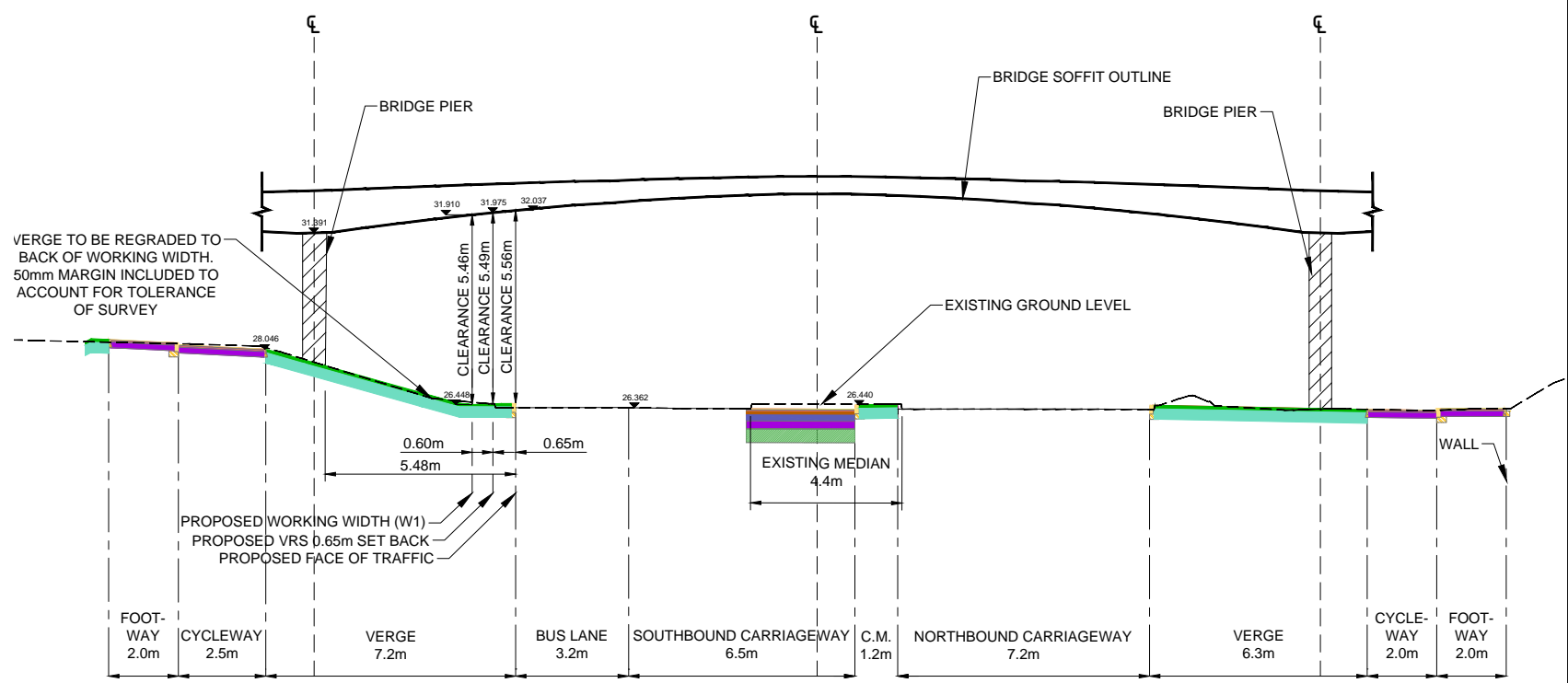

**CROSS SECTION - AA
PROPOSED LAYOUT
SCALE: 1:100 @ A1**

Disclaimer:

a. © National Transport Authority (NTA) 2020. This drawing is confidential and the copyright in it is owned by NTA. This drawing must not be either loaned, copied or otherwise reproduced in whole or in part or used for any purpose without the prior permission of NTA.

b. This drawing is to be used for the design element identified in the titlebox. Other information shown is to be considered indicative only. The drawing is to be read in conjunction with all other relevant design drawings.

c. O.S. data used for plans are printed under © Ordnance Survey Ireland Government of Ireland. All rights reserved. Licence Number 2020/OSI_NMA_180 National Transport Authority. All elevations are in metres and relate to OSI Grid Model (OSGM15) Malin Head. All Co-ordinates are in Irish Transverse Mercator Grid (ITM) as defined by OSI active local GPS station.

d. Information concerning the position of apparatus shown on this drawing is based on drawings supplied by the utility owners and/or the utility works contractor, whilst every care has been taken in the preparation of this drawing, positions should be taken as approximate and are intended for general guidance only and no representation is made by the NTA as to the accuracy, completeness, sufficiency or otherwise of this information. Recipients should not rely on this information. Any liabilities are hereby expressly disclaimed.

e. The information contained herein has been provided by the NTA but does not purport to be comprehensive or final. Recipients should not rely on the information. Neither the NTA nor any of its directors, officers, employees, agents, stakeholders or advisers make any representation or warranty as to, or accept any liability or responsibility in relation to, the adequacy, accuracy, reasonableness or completeness of the information provided as part of this document or any matter on which the information is based (including but not limited to loss or damage arising as a result of reliance by recipients on the information or any part of it). Any liabilities are hereby expressly disclaimed.



Rev	Date	Drm	Chk'd	App'd	Description
M01	27/01/2023	DS	RG	JM	PHASE 4: ISSUE FOR PLANNING

Client: **NTA**
Údarás Náisiúnta Iompair
National Transport Authority

Engineering Designer: **Jacobs**

Date: 27/01/2023
Scale: AS SHOWN @ A1
AS SHOWN @ A3

Project Code: BCIDB
Originator Code: JAC

Drawn: DS
Checked: RG
Approved: JM

QMS Code:

Programme Title: BUSCONNECTS DUBLIN CORE BUS CORRIDORS INFRASTRUCTURE WORKS			
Drawing Title: ROUTE 13 BRAY TO CITY CENTRE ST COLUMCILLE FOOTBRIDGE PROPOSED CROSS SECTION			
Drawing File Name: BCIDB-JAC-STR_GA-0013_BR_00-SK-CB-0002	Sheet Number: 01 of 01	Status: A	Rev: M01

DO NOT SCALE USE FIGURED DIMENSIONS ONLY



Appendix F7
St Annes Retaining Wall
Record of Structural Review

© Copyright 2023 Jacobs Engineering Ireland Limited. The concepts and information contained in this document are the property of Jacobs. Use or copying of this document in whole or in part without the written permission of Jacobs constitutes an infringement of copyright.

Limitation: This document has been prepared on behalf of, and for the exclusive use of Jacobs' client, and is subject to, and issued in accordance with, the provisions of the contract between Jacobs and the client. Jacobs accepts no liability or responsibility whatsoever for, or in respect of, any use of, or reliance upon, this document by any third party.



TRANSPORT INFRASTRUCTURE IRELAND

Record of Structural Review Form

Structure Details

Structure Name	Retaining Structure at St Anne's Roundabout
Structure Number	N/A
Date Commissioned	Unknown
Obstacles Crossed	N/A
Bridge Carries	Wall retains R119 road

Brief Description of Structure

For the purposes of this report the walls on the east and west side of the carriageway will be considered as a single group. The Walls consist of stone masonry construction retaining the highway along a section of the R119 and R837. Site measurements place the retained height of the wall in the region of 2m. Large parts of the structure, at the time of writing this report, are overgrown with vegetation. Thickness of the wall at highway level appears to be in the region of 460mm. It is unknown if the thickness of the wall increases below ground level. A stone masonry parapet, in the region of 900mm high throughout, is provided along the top of the wall. It appears some areas of the parapet have been repaired with concrete blockwork.

Elements to be Reviewed (where not the whole structure)

Reason for Structural Review	Change to loading arrangement
------------------------------	-------------------------------

Existing Assessment Details or Design Records

Inspection for Assessment Date	N/A	Recorded Condition	N/A
Technical Acceptance Report for Assessment	N/A	Status	N/A
Assessment Date	N/A	Report Number	N/A

Current Assessed/Design Capacity (include Reserve Factors)

HA/ALL	N/A	SV	N/A
Critical Elements	N/A. No assessment available		
Parapet	N/A. No assessment available. Level of containment unknown.		
Pier Impact	N/A		
Certification	N/A		
Calculations	N/A		
As built drawings	N/A		

Comments on Assessment or Design

No recent assessment has been undertaken. Date of construction unknown.

Evaluation

Inspection Date	N/A. No recent inspection available
Change in Condition	<p>No recent inspection is available at the time of writing this report. Consequently, no determination can be made on the change in condition in the years since its construction.</p> <p>Visual inspection from the roadside indicates that the wall is in a generally fair condition and with some vertical cracks noted at discrete locations. There is heavy vegetation growth on the lower side of the walls. Some hollow sounding blockwork was noted and there spalling was noted at the south east. There are no obvious signs of settlement and the adjacent highway is free from cracks. Around 50% of the wall was observed to be missing some degree of mortar pointing. No weepholes were noted at any section of the walls. See Appendix E for record of visual inspection.</p>

	The structure appears to be performing adequately without any obvious signs of distress.																																																																																										
Change in Standards	It is likely that the masonry wall was constructed at a similar time to the adjacent rail bridge, of which only the abutments remain of the original structure, and therefore it was likely designed and constructed prior to the adoption of modern standards.																																																																																										
Change in Loading	<p>New highway alignment is proposed for the highway that the structure is retaining. This involves a realignment of the kerb line closer to the retaining walls than the current alignment. This would bring the kerb alignment closer to the historical alignment and bring surcharges more in line with the original design intent. See appendix B for historical records showing original kerb line.</p> <p>See the tables below demonstrating the changes in footway along the walls and approximate retained heights taken at a visual inspection. Refer to Appendix C for indicative locations of measurements.</p> <table border="1" data-bbox="549 853 1485 1167"> <thead> <tr> <th>Location</th> <th>Retained Height (m)</th> <th>Existing Footway (m)</th> <th>Proposed Footway (m)</th> <th>Historic Footway (m)</th> </tr> </thead> <tbody> <tr><td>1</td><td>1.5</td><td>5.1</td><td>3.85</td><td>2.0¹</td></tr> <tr><td>2</td><td>0.9</td><td>6.05</td><td>3.25</td><td>2.0¹</td></tr> <tr><td>3</td><td>0.8</td><td>4.5</td><td>2.8</td><td>1.8¹</td></tr> <tr><td>4</td><td>0.5</td><td>3.65</td><td>2.8</td><td>1.5¹</td></tr> <tr><td>5</td><td>0.4</td><td>2.7</td><td>3.0</td><td>1.5¹</td></tr> <tr><td>6</td><td>0.3</td><td>2.05</td><td>2.9</td><td>1.5¹</td></tr> <tr><td>7</td><td>0.2</td><td>1.6</td><td>2.2</td><td>1.5¹</td></tr> </tbody> </table> <p><small>1 Measurement of footway is scaled from historic drawings and accuracy contains some level of uncertainty</small></p> <p>Table 1: Change in footway width for west wall</p> <table border="1" data-bbox="549 1245 1485 1626"> <thead> <tr> <th>Location</th> <th>Retained Height (m)</th> <th>Existing Footway (m)</th> <th>Proposed Footway (m)</th> <th>Historic Footway (m)</th> </tr> </thead> <tbody> <tr><td>1</td><td>3.2</td><td>2.6</td><td>8.0</td><td>3.0¹</td></tr> <tr><td>2</td><td>2.85</td><td>6.0</td><td>4.7</td><td>3.0¹</td></tr> <tr><td>3</td><td>2.75</td><td>5.35</td><td>4.0</td><td>2.2¹</td></tr> <tr><td>4</td><td>2.6</td><td>4.9</td><td>2.3</td><td>2.2¹</td></tr> <tr><td>5</td><td>2.5</td><td>4.25</td><td>2.3</td><td>2.2¹</td></tr> <tr><td>6</td><td>1.3</td><td>3.4</td><td>2.3</td><td>2.2¹</td></tr> <tr><td>7</td><td>1.0</td><td>2.3</td><td>2.3</td><td>2.2¹</td></tr> <tr><td>8</td><td>0.7</td><td>1.6</td><td>2.0</td><td>2.0¹</td></tr> <tr><td>9</td><td>1.0</td><td>1.5</td><td>1.9</td><td>1.8¹</td></tr> </tbody> </table> <p><small>1 Measurement of footway is scaled from historic drawings and accuracy contains some level of uncertainty</small></p> <p>Table 2: Change in footway width for East wall</p> <p>As can be seen there is a general reduction in footway width in comparison to existing, but proposed widths are comparable or greater than indicated in historical information on previous kerb locations.</p> <p>It is therefore likely that highway loading was previously closer to the wall in the past. There are no obvious signs that the wall was underperforming with these historic loadings. .</p>	Location	Retained Height (m)	Existing Footway (m)	Proposed Footway (m)	Historic Footway (m)	1	1.5	5.1	3.85	2.0 ¹	2	0.9	6.05	3.25	2.0 ¹	3	0.8	4.5	2.8	1.8 ¹	4	0.5	3.65	2.8	1.5 ¹	5	0.4	2.7	3.0	1.5 ¹	6	0.3	2.05	2.9	1.5 ¹	7	0.2	1.6	2.2	1.5 ¹	Location	Retained Height (m)	Existing Footway (m)	Proposed Footway (m)	Historic Footway (m)	1	3.2	2.6	8.0	3.0 ¹	2	2.85	6.0	4.7	3.0 ¹	3	2.75	5.35	4.0	2.2 ¹	4	2.6	4.9	2.3	2.2 ¹	5	2.5	4.25	2.3	2.2 ¹	6	1.3	3.4	2.3	2.2 ¹	7	1.0	2.3	2.3	2.2 ¹	8	0.7	1.6	2.0	2.0 ¹	9	1.0	1.5	1.9	1.8 ¹
Location	Retained Height (m)	Existing Footway (m)	Proposed Footway (m)	Historic Footway (m)																																																																																							
1	1.5	5.1	3.85	2.0 ¹																																																																																							
2	0.9	6.05	3.25	2.0 ¹																																																																																							
3	0.8	4.5	2.8	1.8 ¹																																																																																							
4	0.5	3.65	2.8	1.5 ¹																																																																																							
5	0.4	2.7	3.0	1.5 ¹																																																																																							
6	0.3	2.05	2.9	1.5 ¹																																																																																							
7	0.2	1.6	2.2	1.5 ¹																																																																																							
Location	Retained Height (m)	Existing Footway (m)	Proposed Footway (m)	Historic Footway (m)																																																																																							
1	3.2	2.6	8.0	3.0 ¹																																																																																							
2	2.85	6.0	4.7	3.0 ¹																																																																																							
3	2.75	5.35	4.0	2.2 ¹																																																																																							
4	2.6	4.9	2.3	2.2 ¹																																																																																							
5	2.5	4.25	2.3	2.2 ¹																																																																																							
6	1.3	3.4	2.3	2.2 ¹																																																																																							
7	1.0	2.3	2.3	2.2 ¹																																																																																							
8	0.7	1.6	2.0	2.0 ¹																																																																																							
9	1.0	1.5	1.9	1.8 ¹																																																																																							

	<p>Assuming a conservative angle of internal friction of 35° in line with guidance from PD 6694-1, and assuming a multi graded coarse fill which is typical for the area from historic Geotechnical Information, it can be estimated that there is unlikely to be an increase in traffic surcharge under normal traffic on the West wall.</p> <p>Using the same approximate method, it can be estimated that the East wall would be subject to an increase in highway surcharge at locations 4 and 5.</p> <p>It is likely that the route was used by abnormal loads prior to the construction of the M50 and M11 in the 1970's and 1990's respectively. It should be noted that heavy vehicle weights may have changed since this period.</p> <p>The parapet comprises of a stone masonry wall with a typical height of 900mm and a typical thickness 460mm. An idea of the adequacy of containment can be gained via guidance provided in BS 6679-4. Assuming a low mortar adhesion, 50 kph, and a 2200 kg/m³ density. It can be seen in Figure 4 of the standard, that the minimum thickness of parapet required to achieve the stated containment level is 380mm.</p>
<p>Conclusion</p>	<p>In accordance with AM-STR-06015 clause 2.7 the general approach to retaining walls is as follows "Generally, substructures and foundations, retaining walls and buried structures need not be assessed by calculation unless there are evident signs of movement or cracking determined from an inspection for assessment or any other inspection of the structure, or where traffic loading has a significant effect on the structure."</p> <p>None of the observed defects appear originate from overstressing and the structure appears to be performing adequately with no obvious signs of distress. There is no evidence of movement or propagation of cracks identified on visual inspection. However, it should be noted that not all of the structure could be observed due to vegetation.</p> <p>The new arrangement will bring highway loading closer to the walls on both sides of the carriageway. This is likely to have a negligible impact on the West wall due to the small retained height resulting in no expected traffic surcharge. However, there is an expected increase in traffic loading on the East structure in comparison to the existing arrangement. This would constitute a significant change in loading which should be confirmed quantitatively.</p> <p>A parapet risk assessment has been undertaken which designates this location as high risk for collision. See Appendix D for assessment. The existing parapet has been shown to have sufficient containment in accordance with BS 6779-4. It should be noted that this standard is historical and whilst allows some consideration of risk, does not guarantee compliance with current vehicle collision loading requirements. Additional measures such as provision of bollards or high containment kerbs may be considered appropriate.</p> <p>The existing parapet does not meet the height requirement of 1250mm as stated in DN-STR-03011, however this standard is intended for use on new schemes. Any modifications to the existing parapet to achieve the preferred height would result in a significant visual impact and impact on a heritage asset which contributes significantly to the local character of the area.</p>

	Whilst the parapet height is insufficient for cycle requirements, there is no proposed dedicated cycle lane along this section and the kerblines are set a distance of 2m from the existing parapet. Additional mitigation to the risk to cyclists may be considered in Detailed Design.
Recommendation	
<p>It is recommended that the following investigative works are carried out to allow a more detailed consideration of the impact to the two retaining walls:</p> <ul style="list-style-type: none">• It is recommended that removal of vegetation is carried out to allow for a complete visual “inspection for assessment” of the full extent of the walls.• Additional topographical surveys are required on either side of the walls to confirm retained height and parapet height along the full length.• Geotechnical investigations are required to confirm composition and properties of backfill to determine distribution of highway loads.• Structural investigations should be undertaken to confirm thickness of the walls at various depths, plus strengths and densities of materials. <p>Current assumptions include that the route is currently used as an abnormal load route and this should be confirmed with DRLCC prior to detailed design.</p> <p>Given that it is not expected that the new highway loading will exceed the loading that the West wall was previously subject to and that the wall is in fair condition with no signs of distress. It is unlikely that detailed assessment or strengthening works would be required to the West retaining wall to make it suitable for use in the BusConnects scheme.</p> <p>Further assessment would be recommended for the East retaining wall in order to confirm capacity of the wall for the new loading arrangements. It is possible that strengthening or load alleviation measures may be required to mitigate the impact of any increased loading.</p> <p>It is recommended that standard maintenance and inspection regimes are adopted by the asset owner moving forward in line with best practice. This should include periodic removal of vegetation, repointing and repair of masonry, and consideration should be given to the installation of weepholes to help drain any water trapped behind the walls. Regular inspection would be sensible to monitor these historical structures.</p> <p>No modifications to the existing parapet are recommended due to the level of containment provided by the existing masonry parapet and the visual impact any change would have on the local environment. However, a parapet risk assessment has been undertaken which designates this location as high risk for collision. Additional measures such as provision of bollards or high containment kerbs may be considered appropriate. Consideration should be given to the risk for cyclists from the low height parapet on the East Wall, additional mitigation measures to separate the cycle lane and footway may also be appropriate.</p>	

THE ABOVE IS SUBMITTED FOR ACCEPTANCE

Signed¹



Name

John McElhinney

Position

Lead Structural Engineer

Signed

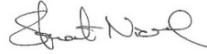

Name

Stuart Nicol

Position

Principal Officer or Director – Design Office

Date

23/06/2021

ACCEPTANCE OF REVIEW FORM

Transport Infrastructure Ireland accepts this certificate

Signed



Name

Position

Structures, Transport Infrastructure Ireland

Date

 / /

1. The persons who sign as Lead Structural Assessment Engineer must be a Chartered Engineer with a recognised University degree to Level 8 or equivalent with a minimum of 10 years post graduate experience in the assessment of bridge structures

Appendix A – Proposed Highway Alignment

LEGEND:

- BUS LANE
- CYCLE TRACK
- FOOTPATH
- CARRIAGEWAY
- GRASS AREA / VERGE
- PEDESTRIAN PRIORITY ZONE
- RAISED TABLE
- BUS STOP LOCATIONS
- BUS SHELTER
- EXISTING TREE TO BE RETAINED
- EXISTING TREE TO BE REMOVED
- PROPOSED TREE
- HERITAGE FEATURES
- SITE BOUNDARY LINE
- TEMPORARY LAND ACQUISITION
- EXISTING BOUNDARY
- EXISTING KERB

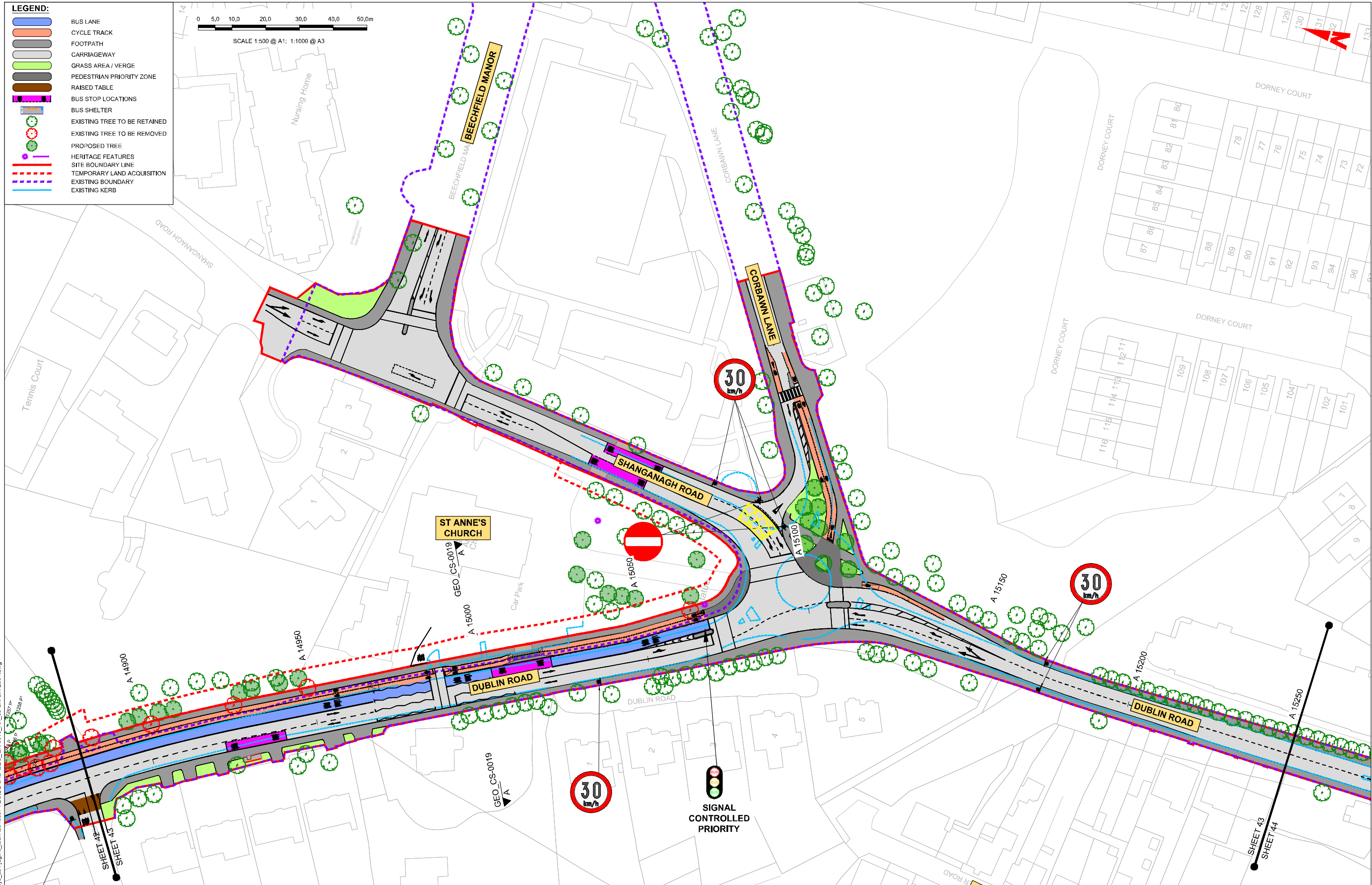
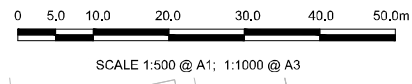

C:\pwworking\jacobs_uk_highways_ssa\legim\leat\00165871BCIDB-JAC-GEO_GA0013_XX_00-SK-CR-2043.dwg

Disclaimers:
 1. National Transport Authority (NTA) 2021. This drawing is confidential and the copyright in it is owned by NTA. This drawing must not be either loaned, copied or otherwise reproduced in whole or in part or used for any purpose without the prior permission of NTA.
 2. This drawing is to be used for the design element identified in the title block. Other information shown is to be considered indicative only. The drawing is to be read in conjunction with all other relevant design drawings.
 3. D.S. data used for items are printed under © Ordnance Survey Ireland Government of Ireland. All rights reserved. Licence Number 2021/OS_NMA_187 National Transport Authority. All elevations are in metres and relate to OS Geoid Model (OSGM15) Mean Head. All Co-ordinates are in Irish

Transverse Mercator Grid (ITM) as defined by OSI active local GPS station.
 Information concerning the position of apparatus shown on this drawing is based on drawings supplied by the utility owners and/or the utility works contractor, whilst every care has been taken in the preparation of this drawing, positions should be taken as appropriate and are intended for general guidance only and no representation is made by the NTA as to the accuracy, completeness, sufficiency or otherwise of this drawing and the position of the apparatus. The information contained herein does not purport to be comprehensive or final as the apparatus is subject to being altered and/or superseded. Recipients should not rely on this information. Any liabilities are hereby expressly disclaimed.

The information contained herein has been provided by the NTA but does not purport to be comprehensive or final. Recipients should not rely on the information. Neither the NTA nor any of its directors, officers, employees, agents, stakeholders or advisers make any representation or warranty as to, or accept any liability or responsibility in relation to, the accuracy, accuracy, reasonableness or completeness of the information provided as part of this document or any matter on which the information is based (including but not limited to loss or damage arising as a result of reliance by recipients on the information or any part of it). Any liabilities are hereby expressly disclaimed.



Rev	Date	Drn	Chk'd	App'd	Description
M01	27/01/2023	SS	RS	CM	PHASE 4: ISSUE FOR PLANNING

 Client		Engineering Designer Jacobs		
Date: 27/01/2023	Scale: 1:500 @ A1; 1:1000 @ A3	Drawn: JM	Checked: RS	Approved: CM
Project Code: BCIDB	Originator Code: JAC	QMS Code		

Programme Title BUSCONNECTS DUBLIN CORE BUS CORRIDORS INFRASTRUCTURE WORKS			
Drawing Title CBC 13 BRAY TO CITY CENTRE EIA GENERAL ARRANGEMENT PLAN			
Drawing File Name: BCIDB-JAC-GEO_GA0013_XX_00-DR-CR-2043	Sheet Number: 43 of 54	Status: A	Rev: M01

DO NOT SCALE USE FIGURED DIMENSIONS ONLY

Appendix B – Historic Information

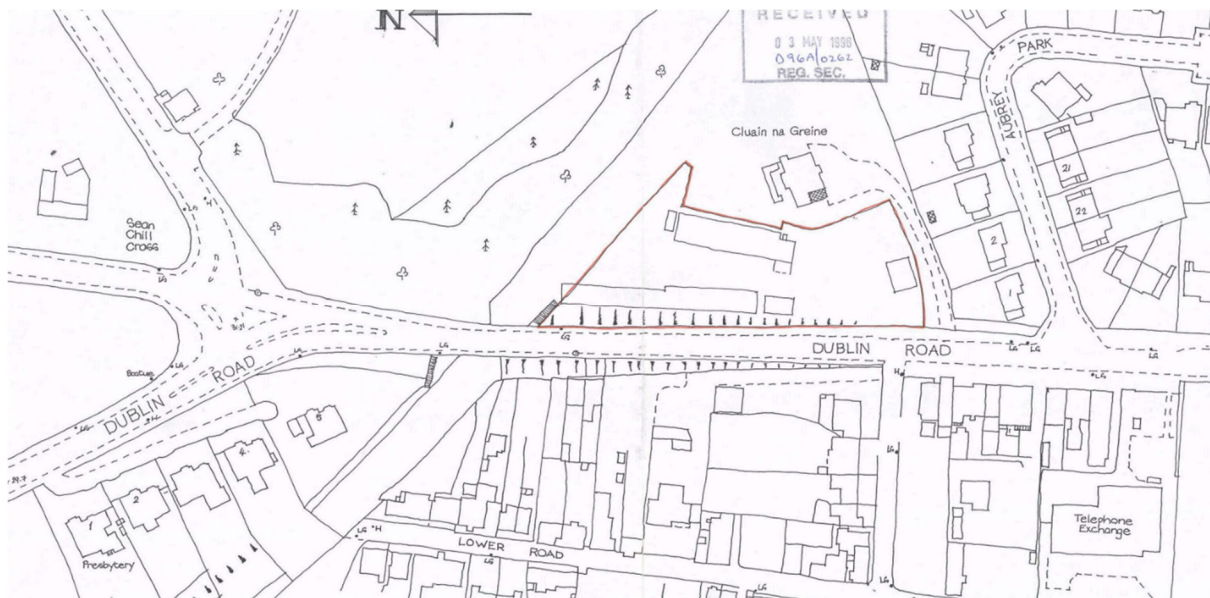

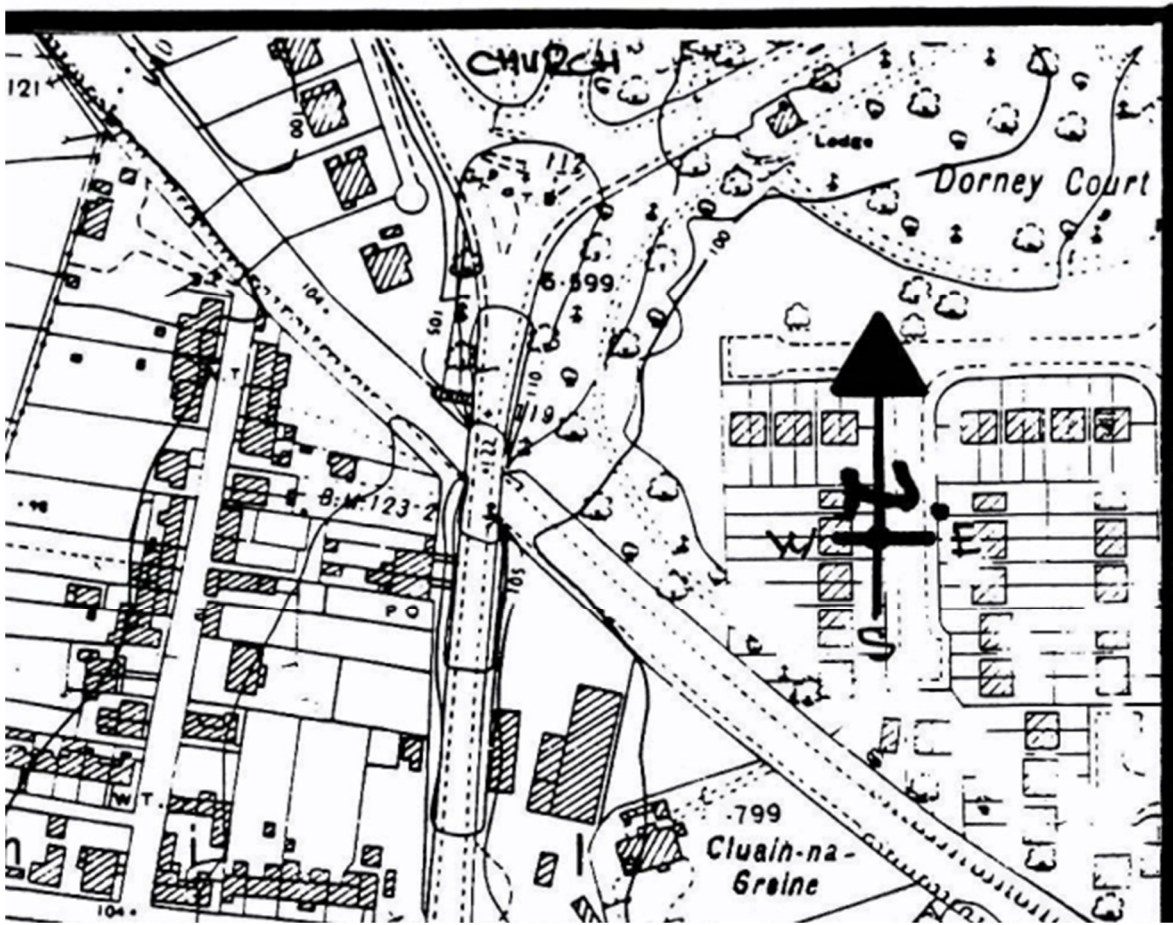

Appendix C – Location of Measurements

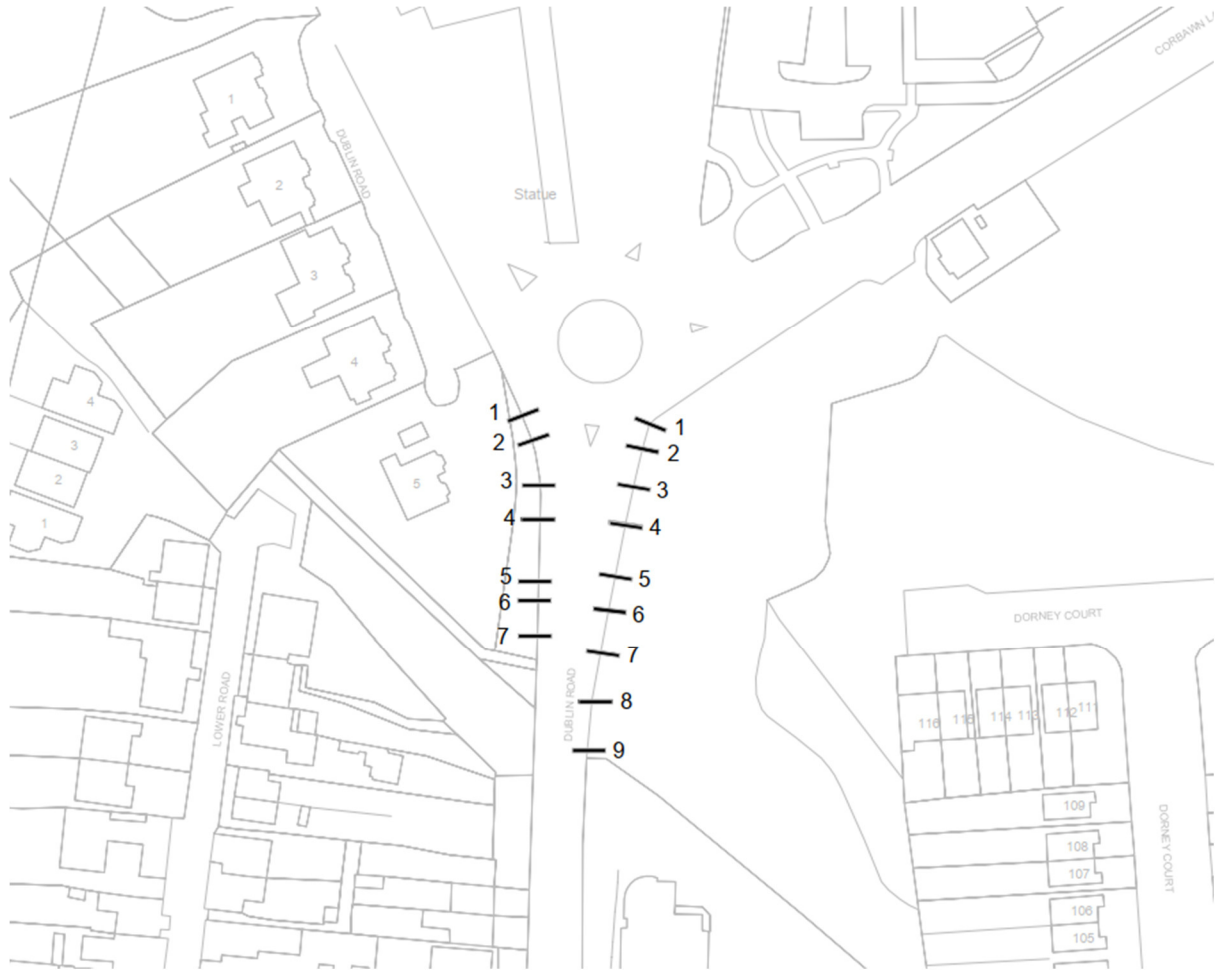

Appendix D: Parapet Risk Assessment



VRS Justification Sheet

Date: 23/06/2021

Completed by: Avril Regan

Location ID/Description:

Bray to City Centre Scheme – St. Annes Roundabout

Site Survey Conducted (Y/N): N

Hazard Type (Start and End Co-ordinates)	Is Hazard within the Clear Zone (Y/N)	Can the Hazard be Mitigated? (Y/N)	Hazard Ranking	Sinuosity Index	Sinuosity Ranking	Collision Rate Threshold	Collision Rate Ranking	Risk of a Vehicle Leaving the Road	Overall Risk Rating	Distance of Hazard	VRS to be Installed (Y/N) Start and End Coordinates	Reasons for Installing/Not Installing the Safety Barrier
1 Retaining Wall Parapets Ch A15163 to A15175	Not applicable to urban situations as per Section 4 of DN-REG-03079	N	High	1.13 (note: because of roundabout there are 3 route options between A and B., worse case considered here)	High	Not available on TII website for this road. From review of RSA collision data a threshold of LOW is assumed due to only 1 minor accidents at the retaining wall location between 2005 and 2016.	Low	Medium	High	11m	If the overall risk rating is High, the hazard shall be mitigated or a VRS shall be provided to meet the requirements of this standard (DN-REQ-03079)	

L = Low, M = Medium, H = High

(1) Hazard Ranking as per Appendix C
 High/Very High (H) as per Appendix C
 Medium (M) as per Appendix C
 Low (L) as per Appendix C

(2) Sinuosity Ranking
 High (H) > 1.02
 Medium (M) = 1.004 ≤ SI ≤ 1.02
 Low (L) < 1.004

(3a) Collision Rate Threshold
 (1) Twice above Expected Rate
 (2) Above Expected Rate
 (3) Below Expected Rate
 (4) Twice Below Expected Rate

(3b) Collision Rate Ranking
 High (H) = Twice above Expected Rate
 Medium (M) = Above Expected Rate
 Low (L) = Below Expected Rate and Twice Below Expected Rate

(4) Risk of a Vehicle Leaving the Road	Collision Rate Ranking			
	H	M	L	
Sinuosity Ranking	H	H	H	M
	M	H	M	L
	L	M	L	L

(5) Overall Risk Rating	Hazard Ranking			
	H	M	L	
Risk of a Vehicle Leaving the Road	H	H	H	M
	M	H	M	L
	L	M	L	L

Appendix E – Inspection Report

BusConnects Dublin Core Bus Corridor Infrastructure Works – Package B

Project No: 32110901
Document Title: St Anne's Retaining Walls Inspection
Document No.: BICDB-JAC-STR_ZZ-0013_RW_00-RP-CB-0001
Revision: L01
Document Status: S2
Date: July 2021
Client Name: National Transport Authority
Client No: N/A
Project Manager: Stuart Nicol
Author: Reece Glennon
File Name: BICDB-JAC-STR_ZZ-0013_RW_00-RP-CB-0001

Jacobs Engineering Ireland Limited

Merrion House
Merrion Road
Dublin 4, D04 R2C5
Ireland
T +353 1 269 5666
F +353 1 269 5497
www.jacobs.com

© Copyright 2020 Jacobs Engineering Ireland Limited. The concepts and information contained in this document are the property of Jacobs. Use or copying of this document in whole or in part without the written permission of Jacobs constitutes an infringement of copyright.

Limitation: This document has been prepared on behalf of, and for the exclusive use of Jacobs' client, and is subject to, and issued in accordance with, the provisions of the contract between Jacobs and the client. Jacobs accepts no liability or responsibility whatsoever for, or in respect of, any use of, or reliance upon, this document by any third party.

Document history and status

Revision	Date	Description	Author	Checked	Reviewed	Approved
L01	01/07/21	Issued for Information	RG	JPM	JPM	CM

Retaining Wall Inspection Proforma

Version: July 2004

<input type="checkbox"/> Superficial		<input checked="" type="checkbox"/> General		<input type="checkbox"/> Principal		<input type="checkbox"/> Special		Form 1 of 1 for this wall	
Wall Name: St Anne Retaining Wall				Wall Ref. R13-RW045		Road Ref/No. Dublin Road			
District: Dublin			Map Ref. N/A		ITM.E: 325316		ITM.N: 221865		
Panel 1 of 1		Retained Height (m)	Max.	Ave.	Wall/Panel Length (m): 90		Retaining Wall Code:		
All above ground elements inspected: Y					Photographs? Y		Structural Form		Retaining Wall
Number of construction forms in wall/panel length: 1							Material		Stone Masonry

Set	No	Element Description		Condition	Comments/Remarks
Wall Elements	1	Foundations		Not Observed	(1) no movement noted (2) Masonry in generally fair condition with 1-5mm vertical cracks noted at discrete locations. Some hollow sounding blocks noted on the east side.
	2	Retaining Wall	Primary	Fair	
	3		Secondary		
	4	Parapet Beam/Plinth			
Durability Elements	5	Drainage			(7) generally fair with some loss of mortar pointing (8) generally fair with some loss of mortar pointing
	6	Movement/Expansion Joints			
	7	Surface finishes: wall		Fair	
	8	Surface finishes: handrail/parapet		Fair	
Safety Elements	9	Handrails/parapets/safety fences		Fair	(9) Parapets in fair condition. Areas of mortar loss and algae growth noted. (10) General wear noted. Damage to kerb and carriageway on west side (12) General wear noted
	10	Carriageway	Top of Wall	Fair	
	11		Foot of Wall		
	12	Footway/Verge	Top of Wall	Fair	
	13		Foot of Wall		
Other Elements	14	Embankments	Top of Wall		
	15		Foot of Wall		
	16	Invert/river bed			
	17	Aprons			
Ancillary Elements	18	Signs			
	19	Lighting			
	20	Services			
	21				
	22				
	23				
	24				

Defect Sketches:

	Inspection Date: 26/05/2021	Next Insp. (month/yr): TBA
--	-----------------------------	----------------------------

Wall Name: St Anne Retaining Wall	Road Name: Dublin Road	
Wall Ref: R13-RW045	Road Ref/No:	
ITM. E 325316	ITM. N 221865	Map Ref:

MULTIPLE DEFECTS

Item No.	Defect 1			Defect 2			Defect 3			Comments
	S	Ex	Def	S	Ex	Def	S	Ex	Def	

INSPECTOR'S COMMENTS

Retaining structures at this location observed to be in a generally fair condition. No leaning or bulging of the masonry was noted. Multiple areas noted with mortar loss and algae growth to be regarded as a durability issue. Some hollow sounding blockwork was noted at discrete locations along the walls. Multiple small vertical cracks noted on the east face, no signs of active movement.

Heavy vegetation growth was obscuring some parts of the structures. Ivy growth noted at multiple locations.

Carriageway and footways show general wear with a damaged kerb noted on the west side of the carriageway.

Name: Alex Bradley

Signed: *A. Bradley*

Date: 14/06/2021

ENGINEER'S COMMENTS

Removal of vegetation to allow a full inspection is recommended.

Local repointing and introduction of weep holes for drainage is advisable.

Regular inspection should be undertaken to allow monitoring of the structure.

Name: John McElhinney

Signed: *J McElhinney*

Date: 14/06/2021

WORK REQUIRED

Ref.No.	Suggested Remedial Work	Priority	Estimated Cost	Action/Work Ordered?

Name:

Signed:

Date:

APPENDIX A Photographs



Figure 1 View of east wall looking north



Figure 2 View of east elevation. Limited access



Figure 3 View of east elevation. Limited access



Figure 4 Typical condition of masonry on east elevation

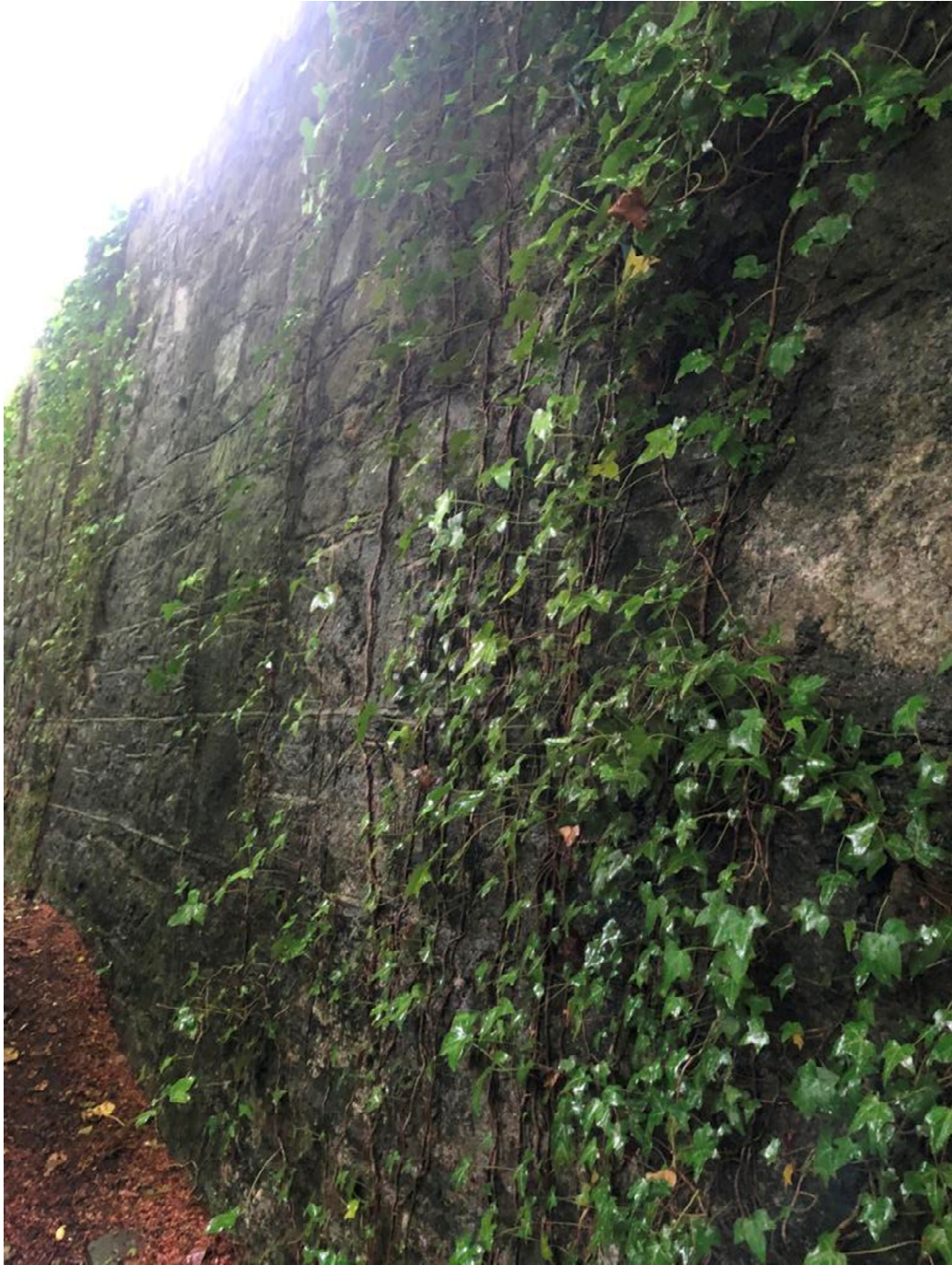

Figure 5 View of east elevation. Significant ingress of vegetation

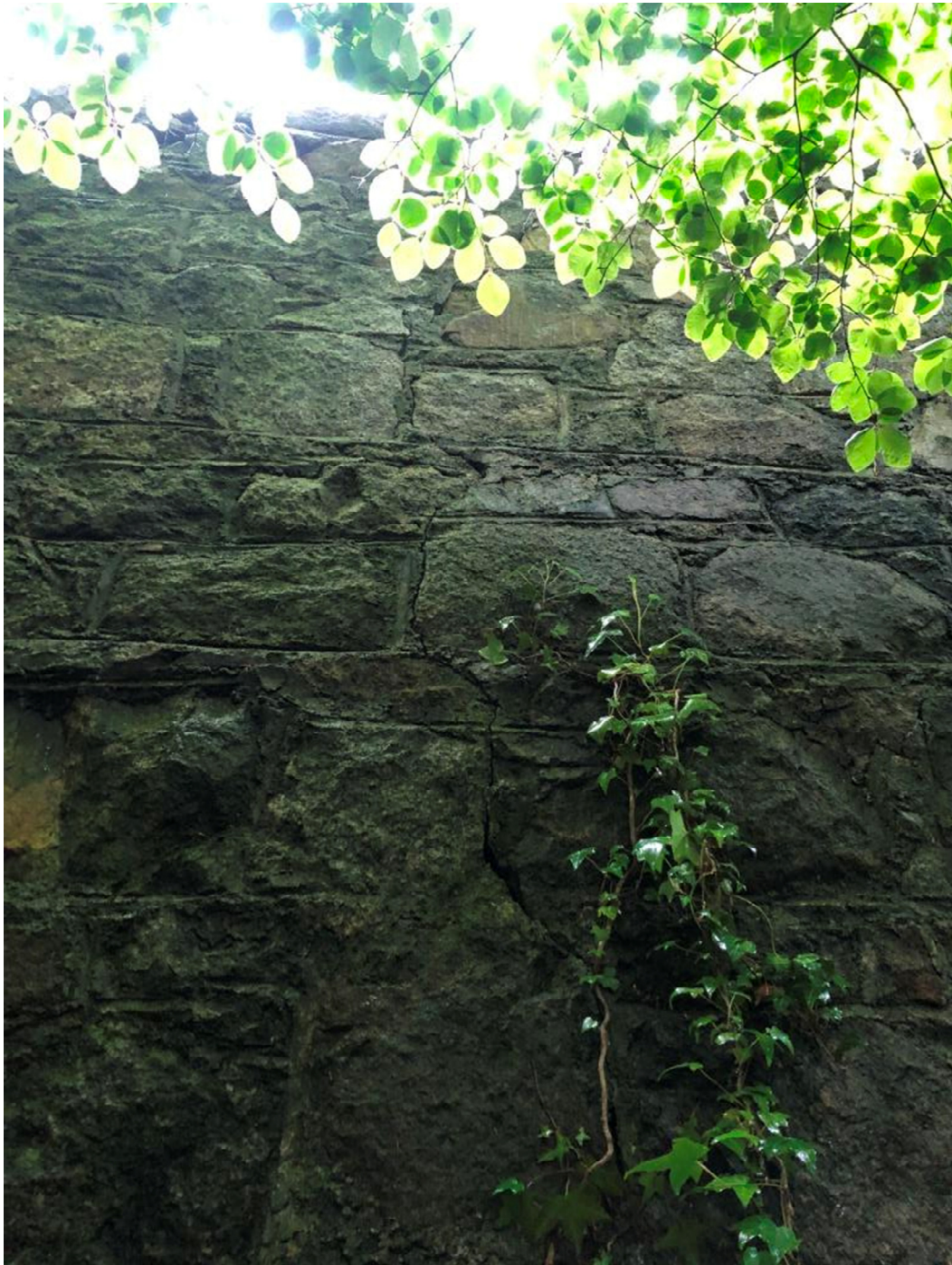

Figure 6 Vertical crack noted on east elevation

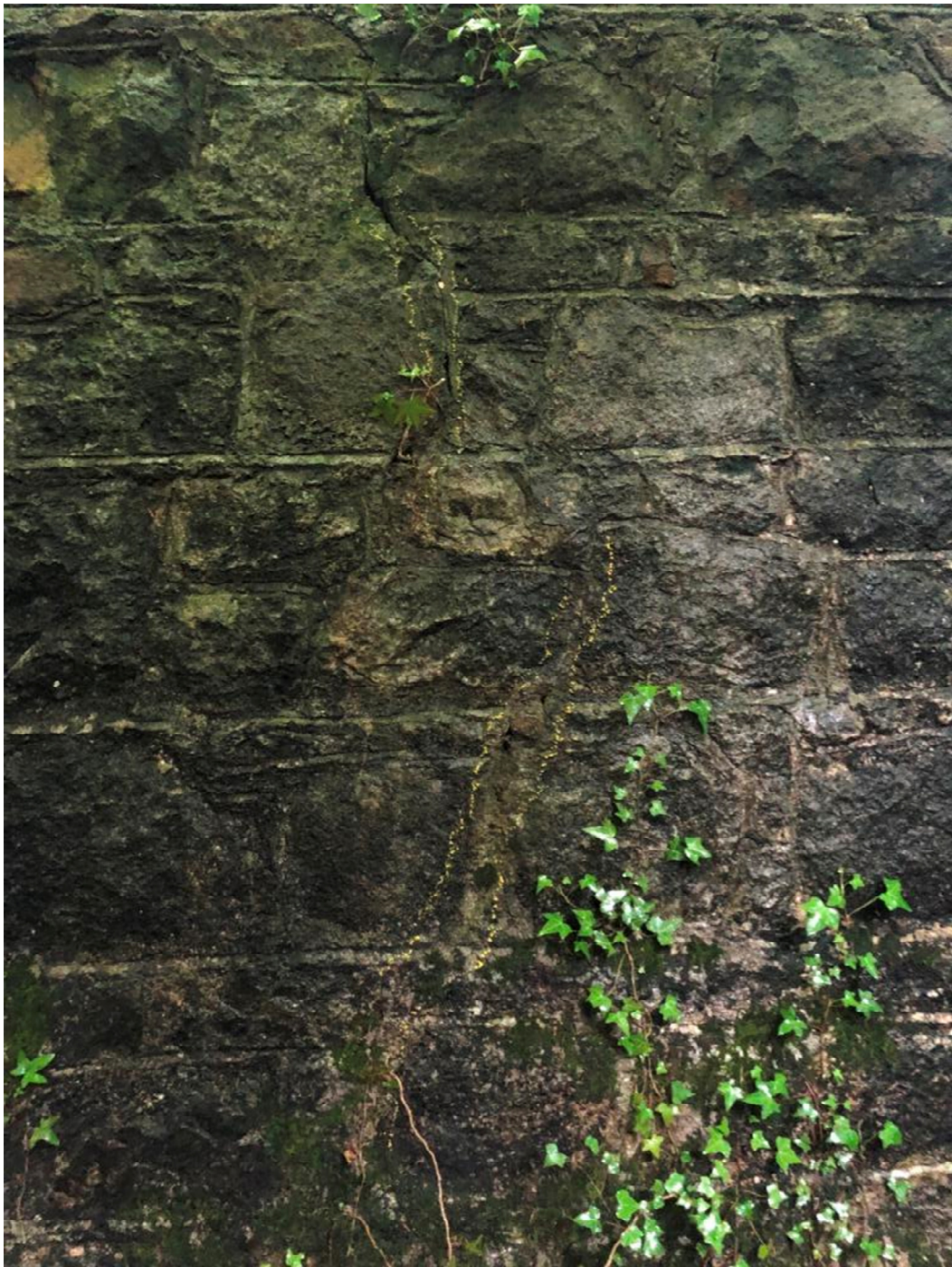

Figure 7 Vertical crack noted on east elevation



Figure 8 Vertical crack noted on east elevation



Figure 9 Algae growth noted at base of east wall.



Figure 10 Vertical crack noted on east elevation



Figure 11, Missing blockwork noted at top of east wall



Figure 12 Hairline cracks noted at multiple locations



Figure 13 Exposed tie bar noted on east elevation



Figure 14 View of west elevation



Figure 15 Extensive vegetation growth obscuring parts of the west elevation



Figure 16 North west parapet in generally good condition.

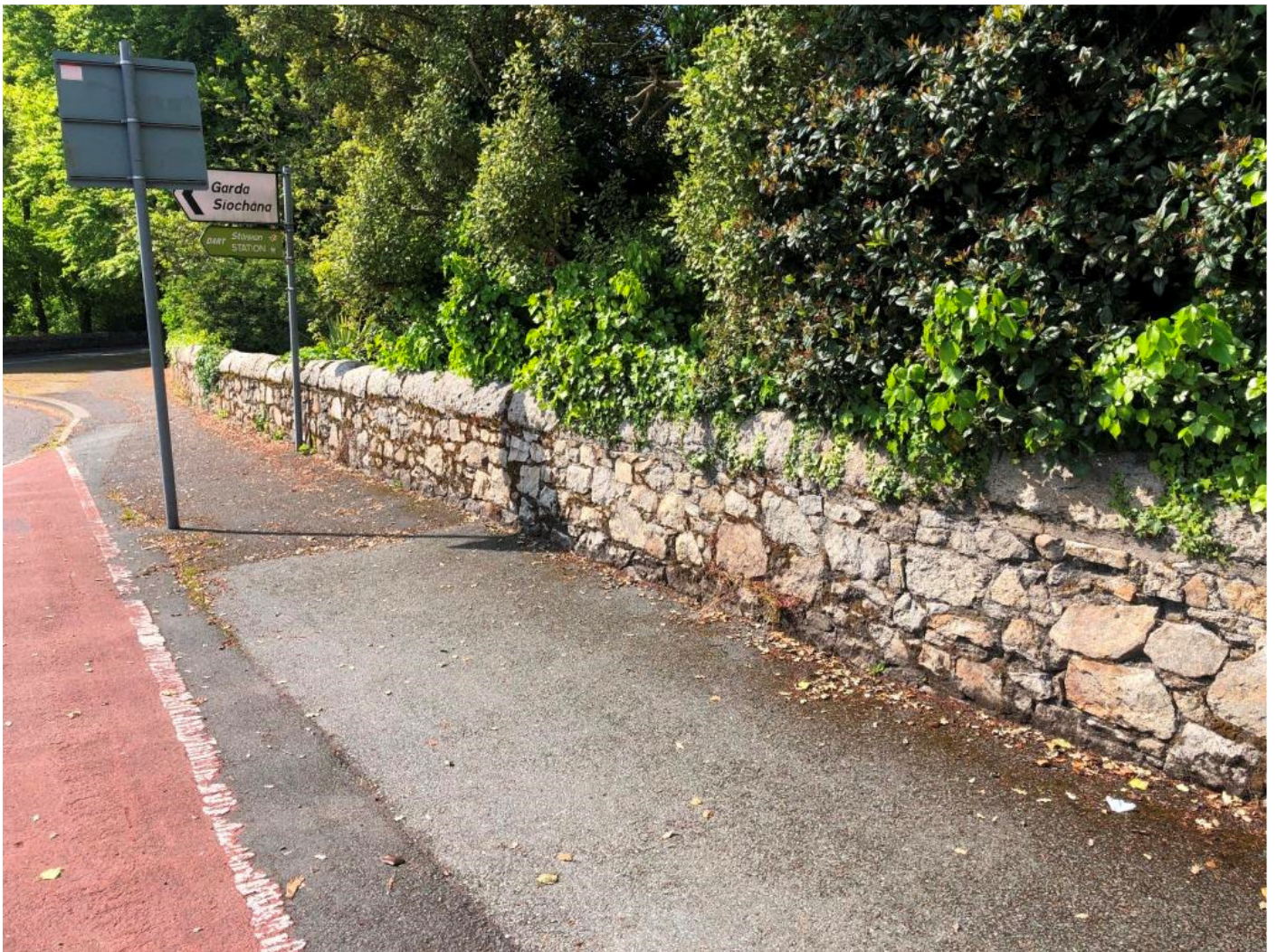

Figure 17 Some loss of mortar on west parapet



Figure 18 Areas of mortar loss and algae growth on the west parapet. General wear noted on footway surfacing



Figure 19 Missing blockwork noted on south west parapet



Figure 20 East parapet in generally good condition. Areas of mortar loss and Algae growth noted.



Figure 21 Damage to west kerb and carriageway noted